



# **E-NOTES OF**

## **Refrigeration & Air Conditioning**

**Name-Kapil Yadav**

**Designation-Lecturer**

**Deptt.-Mechanical Engg.**

**B.K.N. Govt. Polytechnic, Narnaul**



The term **refrigeration** means cooling a space, substance or system to lower and/or maintain its temperature below the ambient one (while the removed heat is rejected at a higher temperature). In other words, **refrigeration** is artificial (human-made) cooling.

**Air conditioning** (often referred to as AC, A/C, or **air con**) is the process of removing heat and moisture from the interior of an occupied space to improve the comfort of occupants. ... In construction, a complete system of heating, ventilation, and **air conditioning** is referred to as HVAC.

**Vapour-compression refrigeration** or **vapor-compression refrigeration system (VCRS)**,<sup>[1]</sup> in which the [refrigerant](#) undergoes [phase changes](#), is one of the many [refrigeration cycles](#) and is the most widely used method for [air-conditioning](#) of buildings and automobiles. It is also used in domestic and commercial refrigerators, large-scale warehouses for chilled or frozen storage of foods and meats, refrigerated trucks and railroad cars, and a host of other commercial and industrial services. [Oil refineries](#), [petrochemical](#) and [chemical](#) processing plants, and [natural gas processing](#) plants are among the many types of industrial plants that often utilize large vapor-compression refrigeration systems. [Cascade refrigeration](#) systems may also be implemented using 2 compressors.

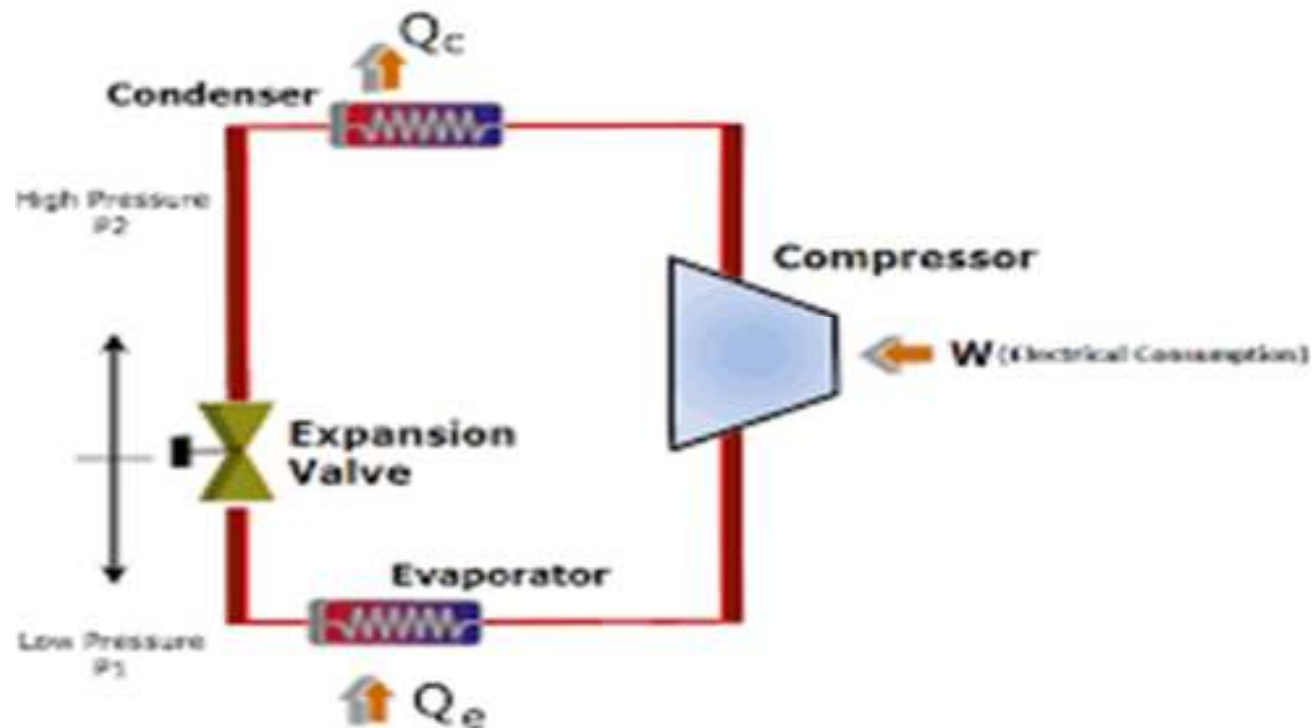

An **absorption refrigerator** is a [refrigerator](#) that uses a heat source (e.g., [solar](#) energy, a fossil-fueled flame, [waste heat](#) from factories, or [district heating](#) systems) to provide the energy needed to drive the cooling process. The system uses two coolants, the first of which performs [evaporative cooling](#) and is then absorbed into the second coolant; heat is needed to reset the two coolants to their initial states. The principle can also be used to [air-condition](#) buildings using the waste heat from a [gas turbine](#) or [water heater](#). Using waste heat from a gas turbine makes the turbine very efficient because it first produces [electricity](#), then hot water, and finally, air-conditioning—[trigeneration](#). Absorption refrigerators are commonly used in [recreational vehicles](#) (RVs), [campers](#), and [caravans](#) because they can be powered with propane fuel, rather than electricity. Unlike more common [vapor-compression refrigeration](#) systems, an absorption refrigerator can be produced with no moving parts other than the coolants.

## Simple vapour absorption system

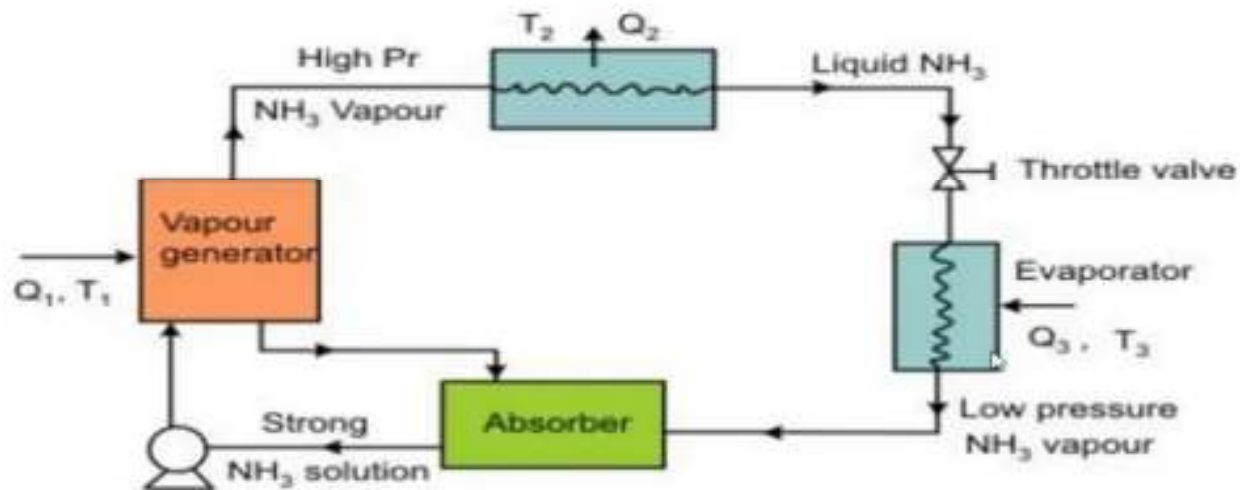



# Definition:

2

- Condenser is a device in which steam is condensed to water at a pressure less than atmosphere.
- Condensation can be done by removing heat from exhaust steam using circulating cooling water.
- During condensation, the working substance changes its phase from vapour to liquid and rejects latent heat.
- The exhaust pressure in the condenser is maintained nearly 7 to 8 kpa which corresponds to condensate temperature of nearly 313 kelvin.

## *Functions of Condenser:*

3

- To reduce the turbine exhaust pressure so as to increase the specific output and hence increase the plant efficiency and decrease the specific steam consumption.
- To condense the exhaust steam from the turbine and reuse it as pure feed water in the boiler. Thus only make up water is required to compensate loss of water
- Enables removal of air and other non condensable gases from steam. Hence improved heat transfer.

## TYPES OF CONDENSER

### AIR COOLED CONDENSER

- ▶ a. Natural convection air cooled condenser
- ▶ b. Forced convection air cooled condenser

### WATER COOLED CONDENSER

- ▶ a. Tube in tube condenser
- ▶ b. Shell and coil condenser
- ▶ c. Shell and tube condenser

# TYPES OF COMPRESSOR:

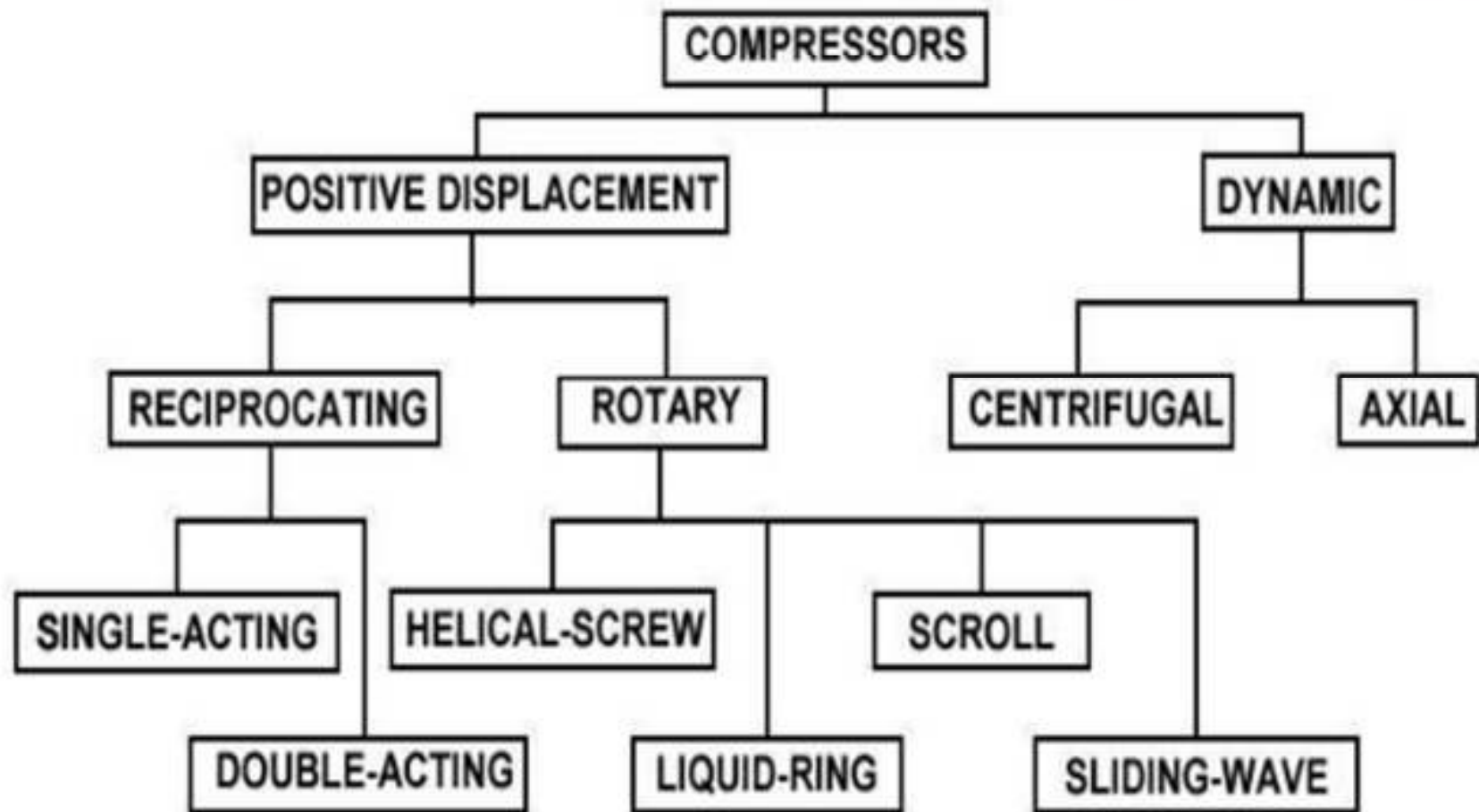

Figure 1-2, Compressor Family Tree



# What is evaporators

---

Evaporators: - An evaporator is a device used to turn the liquid form of a chemical into its gaseous form. The liquid is evaporated, or vaporized, into a gas. Many types of evaporators and many variations in processing techniques have been developed to various products.

# Types Of Evaporators

Based on their construction the various types of evaporators are:

1. Bare Tube Evaporators :
  - a) The bare tube evaporators are made up of copper tubing or steel pipes
  - b) The copper tubing is used for small evaporators where the refrigerant other than ammonia is used
  - c) the steel pipes are used with the large evaporators where ammonia is used as the refrigerant.
  - d) the atmospheric air flows over the bare tube evaporator and the chilled air leaving it used for the cooling purposes..
  - e) The bare tube evaporators are usually used for liquid chilling

**solar-powered refrigerator** is a [refrigerator](#) which runs on energy directly provided by sun, and may include [photovoltaic](#) or [solar thermal](#) energy.

Solar-powered refrigerators are able to keep perishable goods such as meat and dairy cool in hot climates, and are used to keep much needed vaccines at their appropriate temperature to avoid spoilage.

Solar-powered refrigerators are typically used in off-the-grid locations where utility provided AC power is not available.

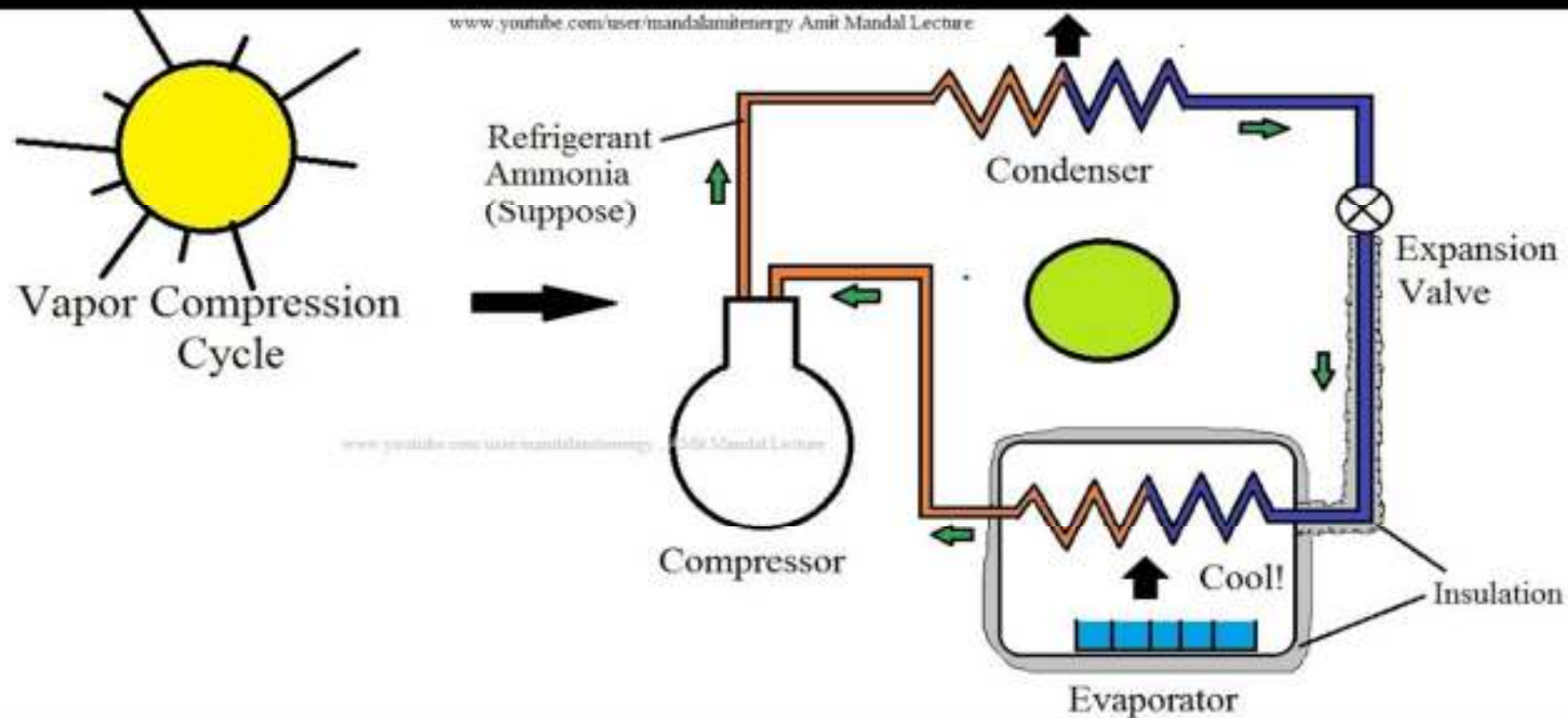

## **Types of Refrigerants**

### **Refrigerants used in industrial spaces**

Here we bring you a list of refrigerants that are majorly adopted for industrial refrigeration plants.

#### **Water**

Water is one of the substances filled with perfect chemical and thermodynamic properties. It has been used as a type of refrigerant for decades due to its easy availability. Well, it can't be considered to be a refrigerant alone, but when chilled in cooling plants, it is put to use in the circuits for lowering the temperatures.

For using water as a refrigerant, there is a need for ambient temperature that is higher than 100° C.

#### **HFC R134A**

This refrigerant is used in air-conditioned cars but also put to use in commercial refrigerant spaces in [refrigerant piping](#). While talking about its features, it is enriched with minimal toxicity, non-combustibility, flawless thermal stability, and non-corrosiveness.

#### **Hydrocarbons (HCS)**

This refrigerant is filled with chemicals that are used in commercial refrigeration systems, air conditioning systems, and domestic refrigeration systems. This refrigerant is apt for industrial cooling as it has propane with zero ODP (Ozone depletion potential). But it needs specific safety installations.

While working with Hydrocarbons, keep certain things in mind for better operation such as avoiding welding in the same area, and staying away from sparks and wire.



## **Ammonia (R717)**

Ammonia is considered to be the oldest and most commonly used refrigerant in industrial cooling plants. It is [power-packed with halogen-free chemicals](#). Here, the application process is in smaller components thereafter eradicating the need for big cooling plants.

Besides, it has a lower molecular weight, high critical points, and a high coefficient of performance, but with this comes the damaging effects.

## **CO2 R744**

This refrigerant has to be handled with care due to its heavyweight, while in a situation of leakage it might replace oxygen. On the brighter side, CO2 R744 has a minimum impact on the environment as it is non-toxic and non-flammable.

A **thermal expansion valve** or **thermostatic expansion valve** (often abbreviated as **TEV**, **TXV**, or **TX valve**) is a component in [refrigeration](#) and [air conditioning](#) systems that controls the amount of refrigerant released into the evaporator and is intended to regulate the superheat of the vapor leaving the evaporator. Although often described as a "thermostatic" valve, an expansion valve does not regulate temperature, the temperature of the evaporator will vary with the evaporation pressure.

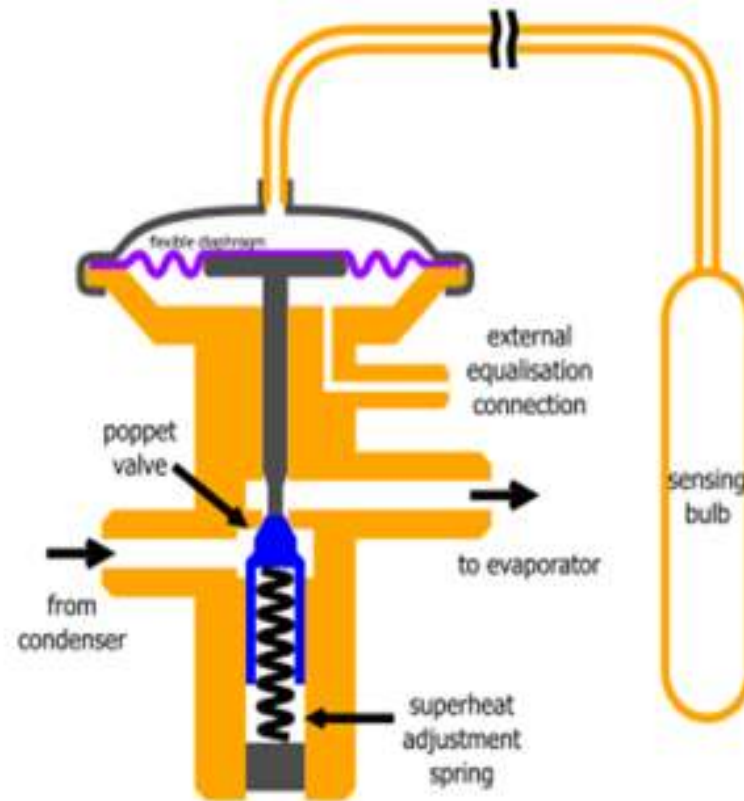

A split air conditioner consists of two main parts – a compressor located outside and an inside air outlet unit. Unlike a system that requires a series of ductwork networked throughout the ceiling, split air conditioners rely on a set of pipes to connect the outdoor to the inside air unit which is why they are referred to as a [ductless mini-split air conditioner installation](#). Refrigerant is dispersed through the copper pipes that cycle through the system to generate either heated or cold air.

