

# ENGINEERING DRAWING, DRAWING INSTRUMENTS, THEIR USE AND CARES

## Unit 1

### 1. Introduction to Engineering Drawing and Graphics

#### 1.1 Drawing.

The art of representation of any object existing in this universe on a piece of paper is known as Drawing.

This is most important and interesting subject used through-out the world by Artists and Engineers. Broadly, the subject of Drawing can be divided into two main groups :

- (1) Artistic Drawing.
- (2) Engineering Drawing,

#### 1.2 Artistic Drawing

The representation of an object on a piece of paper by giving various shades and colours to the object by an artist is known as Artistic Drawing. This drawing gives the general and similar outlook of the object and not the exact shape and size. It is, generally used by the artists for commercial purposes such as in cinema slides, sign and advertisement boards, paintings etc.

#### 1.3. Characteristics Of Artistic Drawing

The following are the characteristics of Artistic Drawing:

- (i) The artistic drawing can be understood or read even by a lay-man.
- (ii) The artistic drawing do not give the exact shape and size of the object.
- (iii) The artistic drawing cannot be used by the workman for the execution of work as it does not include all the informations necessary for the construction of the object.
- (iv) The artistic drawing is not made according to set rules and conventions laid by \*ISI.

#### 1.4. Engineering Drawing

The art of representation of engineering objects such as buildings, bridges, electrical or mechanical machines or Geometrical objects on a piece of paper is known as Engineering Drawing. It is the language used by the engineers especially to convey his thoughts, ideas and designs to others.

#### 1.5. Geometrical Drawing

The art of representation of geometrical objects such as square, rectangle, circle, triangle, polygon, cylinder, cone, 'sphere, pyramid, etc. on a piece of paper is known as Geometrical Drawing.

1.6.1. Plane Geometrical drawing:-The art of representation of plane geometrical figures such as rectangle, circle, triangle, polygon etc. on a piece of paper is known as Plane geometrical drawing.

1.6.2. Solid Geometrical drawing:-The art of representation of solid geometrical objects such as cylinder, cone, sphere, prism, pyramid etc. on a piece of paper is known as Solid geometrical drawing. This is also sometimes known as Descriptive or Practical solid geometrical drawing.

#### 1.6 Civil Engineering Drawing

The art of representation of civil engineering\_ objects such as buildings, bridges,

roads, dams etc. on a piece of paper is known as Civil Engineering Drawing. This drawing is widely used by civil engineers to convey their thoughts and designs to others for actual execution.

### **1.7. Electrical Engineering Drawing**

The art of representation of electrical engineering objects such as generators, motors, transformers, poles and towers etc. on a piece of paper is known as Electrical Engineering Drawing.

### **1.8. Mechanical Engineering Drawing**

The art of representation of mechanical engineering objects such as machines or machine parts on a piece of paper is known as Mechanical Engineering Drawing.

This type of drawing is commonly used by mechanical engineers for mechanical engineering works and projects.

### **1.9 Selection Of Drawing Instruments**

For the preparation of any drawing of an object, it is quite essential to use drawing instruments correctly and accurately in order to get the required degree of of instruments to be used. It is, therefore, essential for the students to purchase instruments of

### **1.10. Drawing Instruments And Other Drawing Materials**

Following is the list of drawing instruments and other drawing materials used fo the preparation of any drawing work

1. Drawing board.
2. T-Square.
3. Set-square (45° and 30°-60°).
4. Protractor.
5. Clinograph.
6. Instrument box.
7. Drawing Pencils and Sand paper block.
8. Scales.
9. Rubber or Eraser.
10. Erasing shield and Electric Erasing machine.
11. Irregular or French curves. 12. Adjustable curves or Splines.
13. Parallel ruler.
14. Drawing paper.
15. Ceilo-tape or Drawing pins.

### **1.11 Modern And Important Drawing Instruments For Speedy And Accurate Work**

The following are the modern and important drawing instruments

1. Drafting machine.
2. Parallel ruling straight edges machine.

### **1.12. Drawing Board**

The board made of 4 to 6 wooden strips of well seasoned and soft wood and used for the purpose of drawing is called drawing board./

The wooden strips of about 20 mm thick and free from all knots and other defects are glued edge to edge to form a board which are again cleated at the back by two battens by means of screws (see fig.1). On the left hand side of the drawing board, a straight ebony or hard wooden smooth strip is fitted to form the working edge of drawing board against which the head (or stock) of T-square moves.

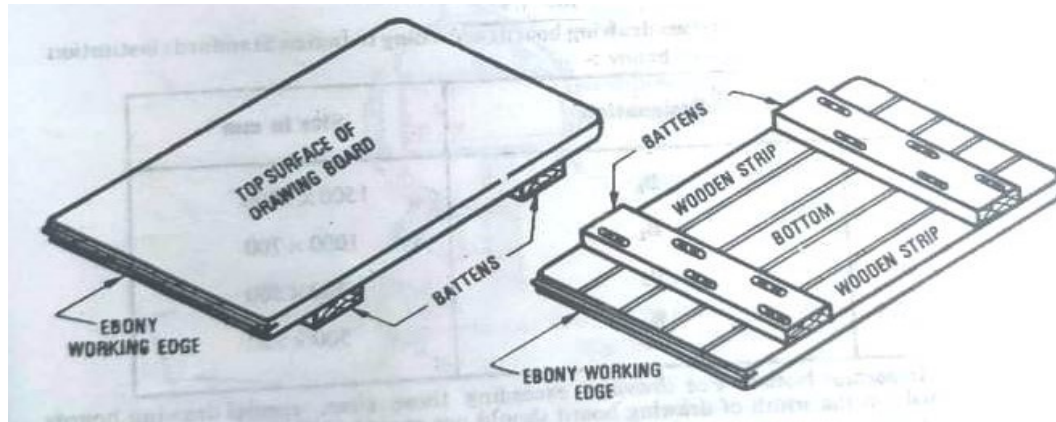

Fig1- Drawing board showing all parts

The standard sizes of various drawing boards according to Indian Standards institution (ISI) and SP: 46-1988 are given below :

Sr. No	Designation	Size in mm
1	B <sub>0</sub>	1500 x 1000
2	B <sub>1</sub>	1000 x 700
3	B <sub>2</sub>	700 × 500
4	B <sub>3</sub>	500x350

### 1.13. T-Square

The arrangement of fixing the two pieces of wood at right angles to each other which form the shape of the alphabet 'T' is known as T-Square.

T-square is made of well seasoned hard wood such as teak or mahogany. It consists of two pieces, namely head or stock, the shorter piece and blade, the longer piece which are pinned together exactly at right angles by means of screws and brass

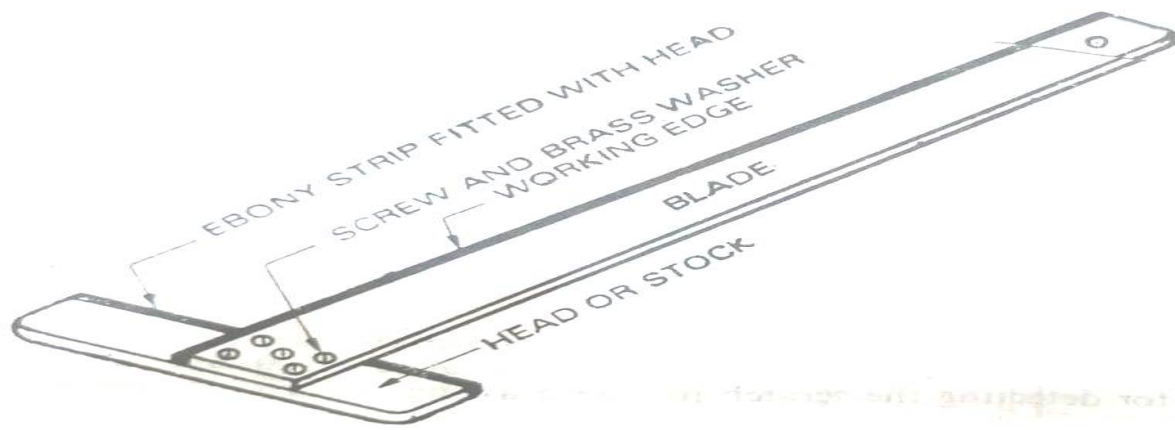

Fig -2 T-Square with its components / parts

### 1.14 Set-Squares

The right angle triangular pieces made of various material which are used for drawing different angles are known as set-squares

Now-a-days, set-squares are generally made of transparent or plastic which are commonly used in engineering practice. The set-squares of such materials are most satisfactory as the lines underneath the set-squares can be seen very easily which prevents always the new lines to be drawn in wrong place.

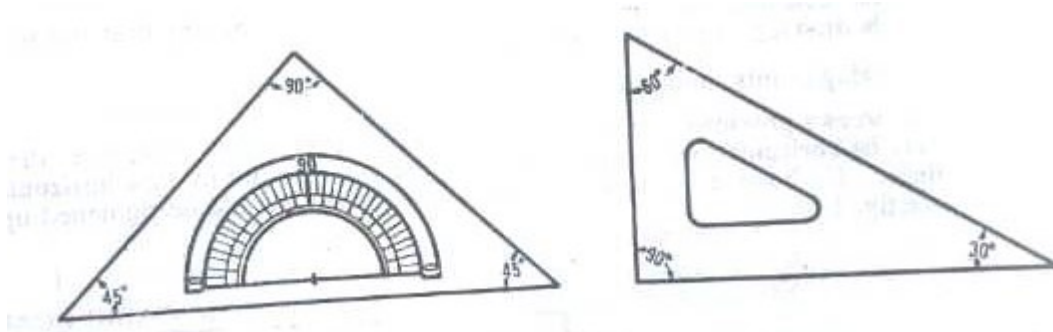

Fig.3- Set-Squares

The set-squares are in the shape of right angled triangles and are of the follow (1) Forty five degree (45°) set-square. ing types Un Thirty-Sixty degree (30°-40°) set-square

The 45 set-square has three edges, one of which form 90 and the remaining two of 45 each The 30°-60° set-square has three edges, one of which form 90° and other edges forming 30 and 60° with other two sides respectively

### 1.15. Clinograph

The adjustable type of set-square which is used to draw parallel and inclined at any desired angle. is known as clinograph.

The two sides of a clinograph are fixed at 90 and its third side can be adjusted

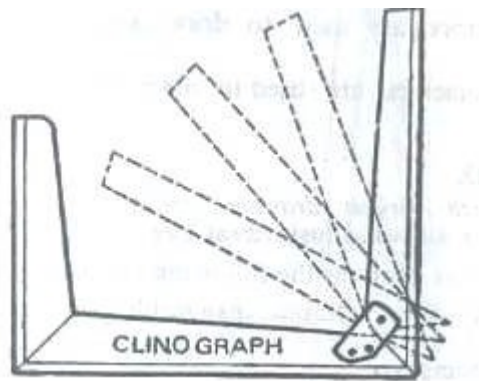

Fig. 4 Clinograph

### 1.16. Protectors

The devices which are used to measure or to draw any line at any angle with the help of set – squares are known as protectors.

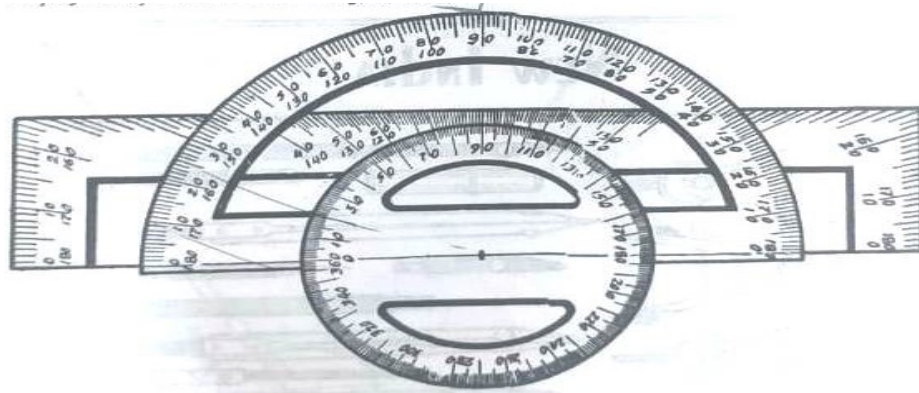

Fig. 5- Protectors

### 1.17, Instrument Box

The box in which various drawing instruments are placed for the purpose of drawing various drawings is known as an instrument box.

The instrument box contains the following instruments: 30

- (i) Large size compass with interchangeable pencil and pen-legs.
- (ii) Large size divider.
- (iii) Small bow compass.
- (iv) Small bow pen.
- (v) Small bow divider.
- (vi) Lengthening bur.
- (vii) Inking pens. Lead case.
- (viii) Small screw driver.

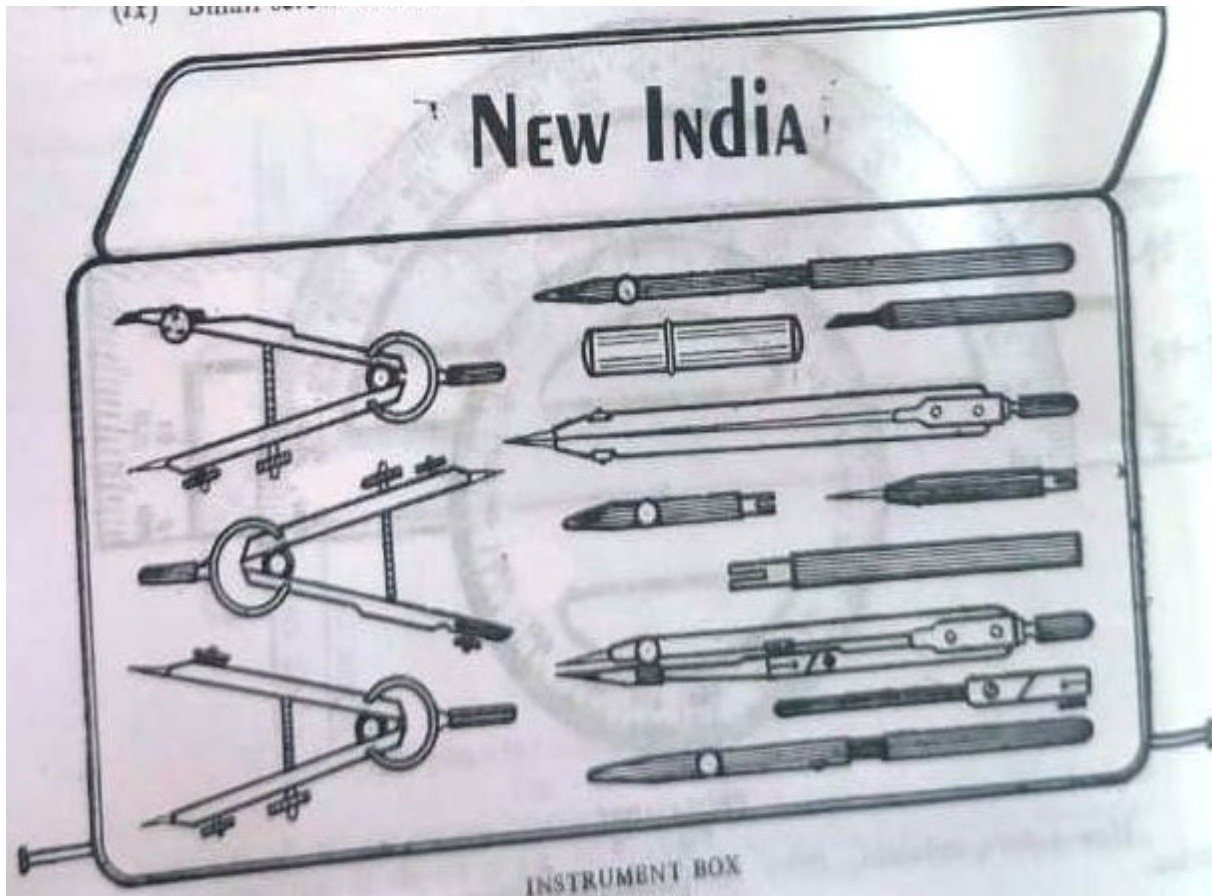

Fig. 6- Instrument Box

### 1.18, Drawing Pencils And Sand Paper Block

The accuracy and appearance of drawing largely depends upon the quality and grade of pencils to be used. The grade of pencil is generally marked by number and letter at one of its ends.

The pencils are graded in the following ways:

- (1) Soft grade pencils: B, 2B, 3B, etc.
- (2) Medium grade pencils : HB.
- (3) Hard grade pencils: H, 2H, 3H, etc.

The number before the letters indicates the degree of softness or hardness as the case may be. For example, a 2H pencil is harder than H and similarly 2B pencil is softer than B.

**Important Note:-**H or 2H pencils are used for actual drawings and HB or H pencils are used for the purpose of lettering, notes and sketching.

### 1.19. Drawing Sheet

The paper which is used for the purpose of drawings is known as drawing sheet. Drawing papers are very essential as we cannot draw any drawing without this. It is, therefore, very essential to use drawing paper of good quality so that accuracy and appearance should be maintained. The paper should be uniform in thickness and of such a quality that the erasing effect should not be there. In addition to this it should be of such a quality that the ink should not spread out.

Sr. No	Designation in mm	Trimmed size	Untrimmed size in mm
--------	-------------------	--------------	----------------------

1	A <sub>0</sub>	1189 x 841	1230 x 880
2	A <sub>1</sub>	594 x 841	625 x 880
3	A <sub>2</sub>	594 x 420	625 x 450
4	A <sub>3</sub>	297 x 420	330 x 450
5	A <sub>4</sub>	297 x 210	330 x 240
6	A <sub>5</sub>	148 x 210	165 x 240

### Layout of a drawing sheet

Every drawing sheet is to follow a particular layout. As a standard practice sufficient margins are to be provided on all sides of the drawing sheet. The drawing sheet should have drawing space and title page. A typical layout of a drawing sheet is shown in the figure below:

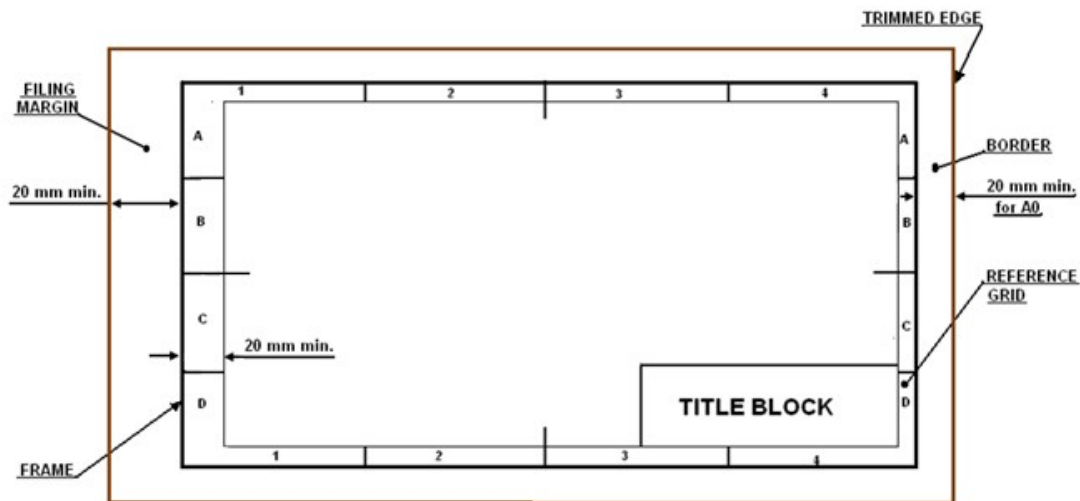

Fig. 7- drawing sheet

Figure . 7 A typical layout of a drawing sheet.

- Borders – A minimum of 10 mm space left all around in between the trimmed edges of the sheet.
- Filing margin – Minimum 20 mm space left on the left hand side with border included. This provided for taking perforations .
- Grid reference system – This is provided on all sizes of industrial drawing sheets for easy location of drawing within the frame. The length and the width of the frames are divided into even number of divisions and labeled using numerals or capital letters. Number of divisions for a particular sheet depends on complexity of the drawing. The grids along the horizontal edges are labeled in numerals where as grids along vertical edges are labeled using capital letters. The length of each grids can be between 25 mm and 75 mm. Numbering and lettering start from the corner of the sheet opposite to the title box and are repeated on the opposite sides. they are written upright. Repetition of letters or numbers like AA, BB, etc., if they exceed that of the alphabets. For first year engineering students grid references need not be followed.
- Title box – An important feature on every drawing sheet. This is located at the bottom right hand corner of every sheet and provides the technical and administrative details of the drawing. The title box is divided into two zones

- a. Identification zone : In this zone the details like the identification number or part number, Title of the drawing, legal owner of the drawing, etc. are to be mentioned.
- b. Additional information zone : Here indicative items like symbols indicating the system of projection, scale used, etc., the technical items like method of surface texture, tolerances, etc., and other administrative items are to be mentioned.

**Layout of the title box recommended for Engineering Drawing Course**  
 The title box shown in figure. can be used for the engineering Drawing Course.

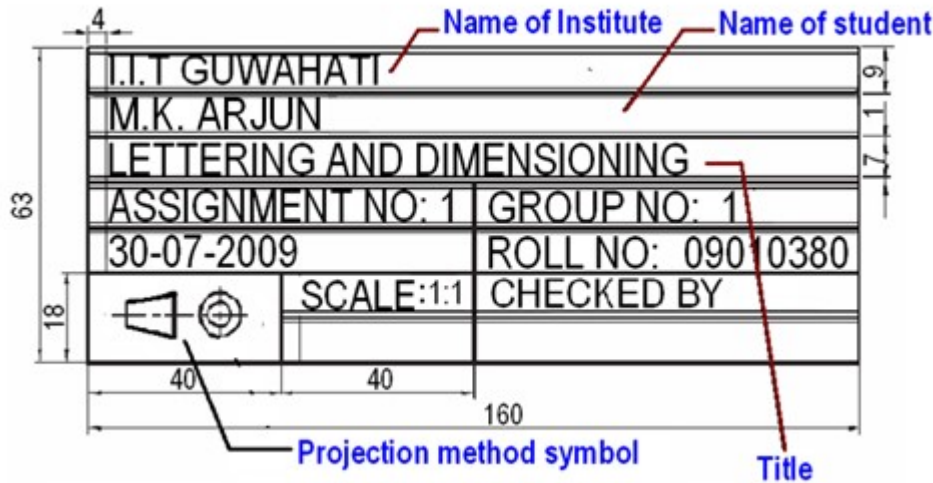

Figure. 8 A typical title box recommended for Engineering students.

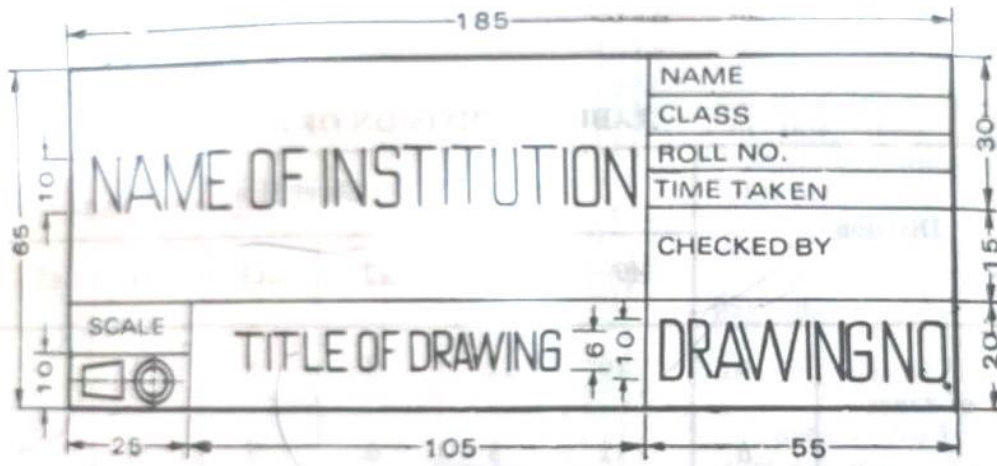

Fig. 9 Title block

**1.20 Modern And Important Drawing Instruments For Speedy And Accurate Work**

The following are the important two modern instruments for speedy and accurate work :

- (1) Drafting machine.
- (ii) Parallel ruling straight edge machine.

**Drafting machine** :-The important machine which perform the functions of T square, set-squares, scales and protactors is known as drafting machine.

Now-a-days, this machine is being very extensively used in industries and commercial departments because it saves time from 25 to 50%









The drafting machine consists of two arms fixed on a circular disc in such a way that two arms can move smoothly and freely. The one end of the movable arm is hinged by means of various hinges as the gripping plate which is further attached to the edge of the drawing board. The other end of the movable arm is hinged to another disc where two fixed scales are provided at right angles ( $90^\circ$ ) .o each other. Along with the scale plate, angular graduations varying form  $0^\circ$  to  $360^\circ$  or to  $180^\circ$  right and left are provided which acts as a protactor.

Two screws are provided, one on the gripping plate and other on the scale disc - loosen or tighten the arms.

## **1.2 Symbols and conventions**

### **1.2.1 Different types of lines**

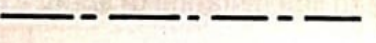
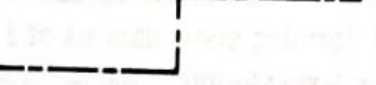
**Conventions for Various Lines [According to B.I.S. S.P. : 46]**

Line	Description	General Application
A 	Continuous Thick	Visible outline Visible Edges
B 	Continuous Thin Straight or Curved	Imaginary lines Dimension lines Projection lines Leader Lines Hatching Outlines of Revolved Surfaces Short centre lines
C 	Continuous Thin Freehand	Limits of Partial Views and Sections
D 	Continuous Thin (Straight with zigzags)	a chain thin line Long break line
E 	Dashed Thick	Hidden outlines Hidden edges
F 	Dashed Thin	Hidden outlines Hidden edges
G 	Chain Thin	Centre lines Lines of Symmetry Trajectories
H 	Chain Thin, Thick at ends and changes of direction	Cutting planes
J 	Chain Thick	Indication of line of sight a special revolved surface

**Line Strokes**

Line strokes refer to the directions of drawing straight and curved lines. The standards for lines is given in BIS : SP-46, 2003

Vertical and inclined lines are drawn from top to bottom, horizontal lines are drawn from left to

right. Curved lines are drawn from left to right or top to bottom. The direction of strokes are illustrated in figure 10.

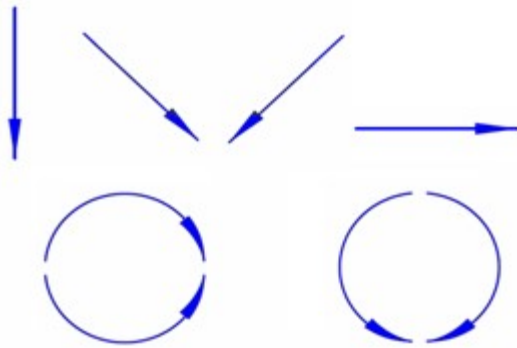

Figure 10. The line strokes for drawing straight and curved lines.

### Conventions used in lines

- International systems of units (SI) – which is based on the meter.
- Millimeter (mm) - The common SI unit of measure on engineering drawing.
- Individual identification of linear units is not required if all dimensions on a drawing are in the same unit (mm).
- The drawing should contain a note: ALL DIMENSIONS ARE IN MM. (Bottom left corner outside the title box)

Typical figures showing various lines used in the construction of engineering drawing is shown in figure 11.

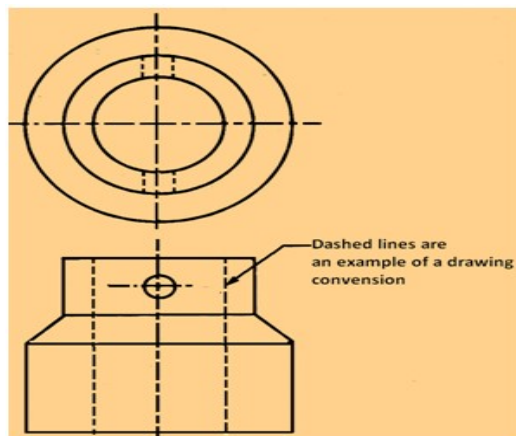

Figure 11 Typical figure showing various lines used engineering drawing

A typical use of various lines in an engineering drawing is shown in figure 12 below:

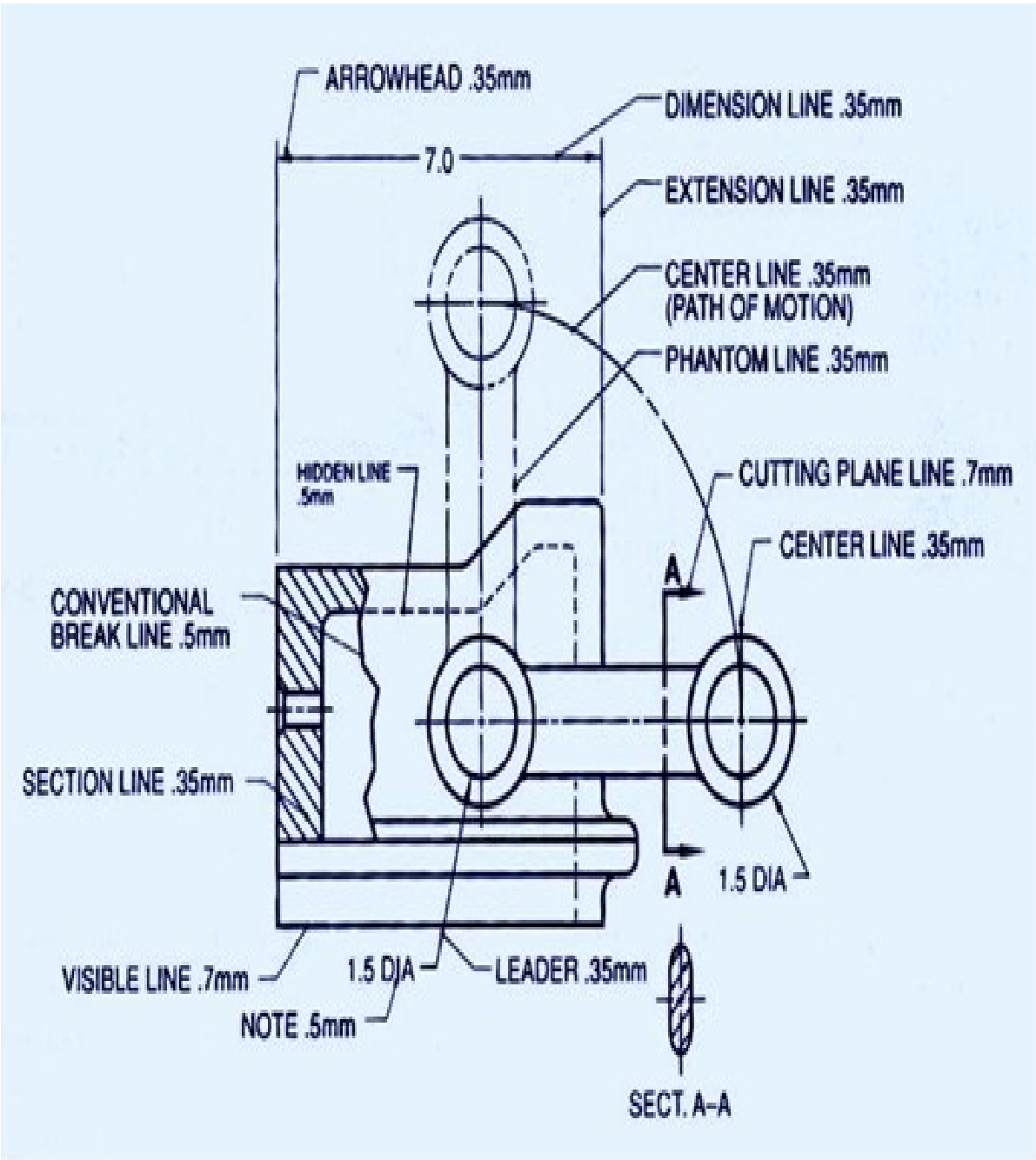











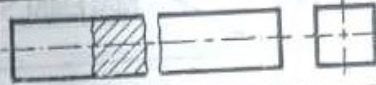
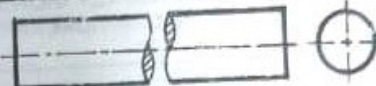

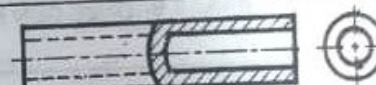
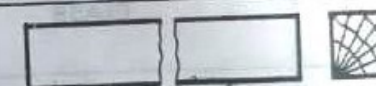

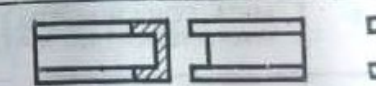

Fig. 12













1.2.2 Conventions for materials









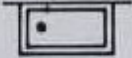
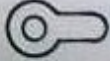





S. No.	MATERIALS	CONVENTION
1	STEEL, CAST IRON, COPPER, ALUMINIUM, AND ITS ALLOYS	
2	LEAD, ZINC, TIN, WHITE METAL, ETC.	
3	BRASS, BRONZE, GUN METAL, ETC.	
4	GLASS	
5	PORCELAIN, STONE WARE, MARBLE, SLATE, ETC.	
6	ASBESTOS, FELT, PAPER, MICA, CORK, RUBBER, LEATHER, WAX, INSULATING MATERIALS.	
7	WOOD, PLYWOOD, ETC.	
8	EARTH	
9	BRICK WORK, MASONRY, FIRE BRICKS, ETC.	
10	CONCRETE	
11	WATER, OIL, PETROL, KEROSENE, ETC.	

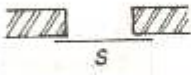
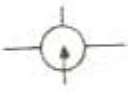



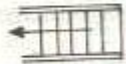
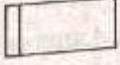





















### 1.2.3 Conventions for Break

S.No.	OBJECT	CONVENTION
1	RECTANGULAR SECTION	
2	ROUND SECTION	
3	PIPE OR TUBING	
4	PIPE OR TUBING	
5	WOOD RECTANGULAR SECTION	
6	ROLLED SECTION	
7	CHANNEL SECTION	

CONVENTIONAL BREAKS

Sr. No.	Description	Symbol	Sr. No.	Description	Symbol
1.	Single Leaf Door Single Swing		8.	Kitch Sink with single drainage board.	
2.	Single Leaf Door Double Swing		9.	Refrigerator	
3.	Sliding Door		10.	Washing Machine Automatic	
4.	Rectangular bath		11.	Pump	
5.	Roll rim bath		12.	Shower Head	
6.	Bidet		13.	Wash hand basin	
7.	Plain kitchen sink		14.	Indian type (WC)	

Sr. No.	Description	Symbol	Sr. No.	Description	Symbol
15.	Western style water closet (WC)		23.	Urinal corner hung	
16.	Double Leaf Door Single Swing		24.	Stop valve or sluice valve	
17.	Double Leaf Door Double Swing		25.	Drain cock	
18.	Rolling Shutter (External)		26.	Mixing valve hand control	
19.	Urinal wall hung		27.	Water meter	
20.	Towel rail		28.	Stairs	
21.	Bed		29.	Safety valve	
22.	Urinal stall		30.	Man Hole or Inspection Chamber	

Sr. No.	Description	Symbol	Sr. No.	Description	Symbol
1.	Main fuse board without switches (lighting)		14.	(iii) Three pole	
2.	Main fuse board with switches (lighting)		15.	Two way switch	
3.	Main fuse board without switches (Power)		16.	Intermediate switch	
4.	Main fuse board with switches (Power)		17.	Push button or bell push	
5.	Distribution fuse board without switches (lighting)		18.	Socket outlet 2 pin 5 amp.	
6.	Distribution fuse board with switches (lighting)		19.	Socket outlet 3 pin 5 amp.	
7.	Distribution fuse board without switches (Power)		20.	Socket outlet and switch combined 3 pin 5 amp.	
8.	Distribution fuse board with switches (lighting)		21.	Socket outlet 2 pin 15 amp.	
9.	Main switch lighting		22.	Socket outlet 3 pin 15 amp.	
10.	Main switch power		23.	Socket outlet and switch combined 3 pin 15 amp.	
11.	Energy meter		24.	Lamp or outlet for lamp	
12.	One way switch (i) Single pole		25.	Lamp mounted on wall	
13.	(ii) Two pole		26.	Lamp mounted on ceiling	

27.	Spot light		44.	Aerial	
28.	Flood light		45.	Bell connected to fire alarm switch	
29.	Fluorescent lamp		46.	Heater	
30.	Group of two fluorescent lamp		47.	Automatic fire detector switch	
31.	Ceiling fan		48.	Direct current (DC)	
32.	Bracket fan		49.	Alternating current (ac)	
33.	Exhaust fan		50.	Battery	
34.	Fan regulator		51.	Generator	
35.	Storage type electric water heater		52.	Motor	
36.	Electric bell		53.	Ammeter	
37.	Buzzer		54.	Voltmeter	
38.	Siren		55.	Indicator	
39.	Horn or Hooter		56.	Surface conduit wiring	
40.	Earth point		57.	Concealed conduit wiring	
41.	Fuse		58.	Wiring going upward	
42.	Signal lamp		59.	Wiring going downward	
43.	Immersion water heater		60.	Thermostat	

## EXERCISES

## A. MULTIPLE CHOICE QUESTIONS:

- The dimensions of drawing board B, to be used with drawing sheet of size A, are
  - $1000 \times 700 \times 25$
  - $700 \times 500 \times 15$
  - $1500 \times 1000 \times 25$
  - $500 \times 350 \times 15$
- The art of representation of engineering object such as building, roads, machines etc. on a paper is called
  - drawing.
  - artistic drawing.
  - geometrical drawing.
  - engineering drawing.
- The representation of engineering object on a piece of paper is called engineering drawing.
  - graphical
  - dimensional diagram
  - real shape
  - None of above.
- 9H grade pencil is
  - hardest.
  - medium.
  - softest.
  - None of the above.
- Size of A, trimmed drawing sheet according to IS is given as
  - $841 \times 1189$
  - $420 \times 594$
  - $594 \times 841$
  - $297 \times 420$
- Which of the following information is given by title block?
  - Symbol of orthographic projection.
  - Type of pencil used.
  - Margin.
  - All of the above.
- The size of the title block used by engineering students is
  - $150 \times 50$
  - $185 \times 65$
  - $185 \times 60$
  - $150 \times 65$
- In reducing scale,
  - the actual measurements are reduced to same appreciate proportion
  - the actual measurements are reduced to different appropriate proportion.
  - the actual measurements are increased to same appropriate proportion.
  - the actual measurements are increased to different appropriate proportion.
- An untrimmed drawing sheet having size  $880 \times 1230$  is designated as
  - $A_1$
  - $A_2$
  - $A_3$

(d) A<sub>0</sub>

10. Size of trimmed drawing sheet of size A, is

(a) 210 x 295

(c) 200 x 295

(b) 210 x 297

(d) 200 x 297

11..... is the softest pencil used in engineering drawing.

(a) HB

(b) 9H

(c) 78

(d) None of above.

12. Designated B1 drawing board has the size of (a) 1000 x 700

(c) 700 x 700

(b) 700 x 500

(d) None of the above.

13. What is the function of T-square? (a) It is used to draw horizontal lines.

(b) It is used as a base with set squares to draw various angles.

(c) Both (a) and (b).

(d) None of (a) and (b)

14. A small size of drafting machine used by the students is called

(a) protractor.

(c) T-square.

(b) mini drafter.

(d) None of the above.

15. Which of the followings is a hidden line?

(a) -----.....-----.....-----.....-----

(b)---.---.---.---.

(c) \_\_\_\_\_

(d) \_\_\_\_\_

16. Which of the following is a centre line:

(a) -----.....-----.....-----.....-----

(b)---.---.---.---.

(c) \_\_\_\_\_

(d) \_\_\_\_\_

17. When a dotted line coincide with a solid line, which of these will take precedence over the other?

(a) Dotted line

(b). Solid line

(c) Does not matter

(d) None of the above.

18. Continuous thin line is used to show

(a) dimension line

(b) leader line.

- (c) projection line.
  - (d) All of the above.
19. One main type of line which comes under thick lines category is
- (a) center line.
  - (b) dotted line.
  - (c) object line.
  - (d) All of the above.
20. Dimension line
- (a) is a thin continuous line.
  - (c) may be broken at the centre
  - (d) All of the above.
21. Cutting plane lines are shown by
- (a) thin chain lines thick at ends.
  - (b) is terminated by arrow heads.
  - (c) continuous thick lines.
22. Long break lines are shown by
- (a) chain thin lines.
  - (b) continuous thin wavy lines.
  - (c) short length
  - (d) equal length,
23. Short break line is used to represent break of an object of
- (b) considerable length.
  - (d) None of the above.
24. Medium equally spaced paired dashes with a space between each pair is known as line.
- (a) hidden.
  - (b) center
  - (c) ditto.
  - (d) short break.
25. Thin alternately long dash and dot is used for
- (a) section line.
  - (b) extension line.
  - (c) transmission line.
  - (d) object line.
26. The following line is used to represents:
- (a) short break line.
  - (b) cutting plane line.
  - (c) centre line.
  - (d) border line.
27. Centre line and dimension line come under the category of..... lines.
- (a) thick
  - (c) medium
  - (b) thin
  - (d) (None of the above).
28. A line generally placed outside the outline of the object and terminating at each end by an arrow head giving the size or length of the object is.....line.

- (a) construction
  - (b) ditto
  - (c) dimension
  - (d) None of the above.
29. Section lines are generally drawn at an angle of..... to the horizontal.
- (a) 30
  - (b) 60°
  - (c) 45
  - (d) 75°
30. A hidden object is shown by .line.
- (a) dash
  - (b) centre
  - (c) long break
  - (d) cutting plane

#### ANSWERS

- |         |        |         |        |         |
|---------|--------|---------|--------|---------|
| 1.(c)   | 2.(d)  | 3.(a)   | 4.(a)  | 5.(a)   |
| 6.(a)   | 7.(b)  | 8. (a)  | 9. (d) | 10.(b)  |
| 11. (c) | 12.(a) | 13.(c ) | 14.(b) | 15.(c ) |
| 16.(b)  | 17.(b) | 18.(d)  | 19.(c) | 20.(d)  |
| 21.(a)  | 22.(b) | 23(a)   | 24.(c) | 25.(c)  |
| 26(b)   | 27.(b) | 28.(c)  | 29.(c) | 30.(a)  |

#### B. SHORT ANSWER QUESTIONS:

1. Define drawing.
2. Classify drawing.
3. What is artistic drawing?
4. What is engineering drawing?
5. Differentiate between drawing and engineering drawing.
6. Classify engineering drawing.
7. What is plane geometrical drawing?
8. What is solid geometrical drawing?
9. Enlist the major drawing instruments and materials.
10. What are the main parts of a drawing board?
11. Give the designation and sizes of different drawing boards.
12. What is the use of drafting machine?
13. What do you know about T-square?

14. What are the user of set squares?
15. What is clinograph?
16. What do you understand by grades of pencils?
17. Give the function of circle master.
18. Give the designation and sizes of drawing sheets.
19. What do you mean by margin?
20. What are the main informations contained in title block?
21. What is engineering drawing? Explain its different types.
22. Define object line.
23. What is hidden line?
24. What is centre line?
25. What do you mean by construction, projection and section lines?

## Geometric Construction

Drawing consists of construction of primitive geometric forms viz. points, lines and planes that serve as the building blocks for more complicated geometric shapes and defining the position of object in space.

The use of lines for obtaining the drawing of planes is shown in figure 1.

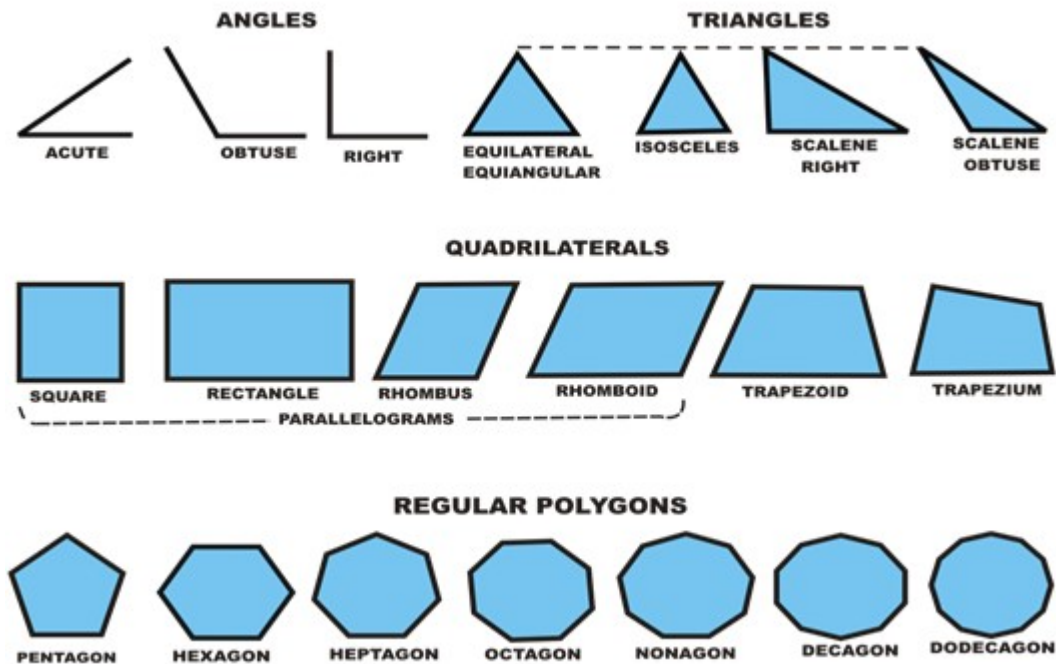

Figure 1 illustrates various planes generally encountered

Solids are obtained by combination of planes. Plane surfaces of simple solids are shown in figure 2.

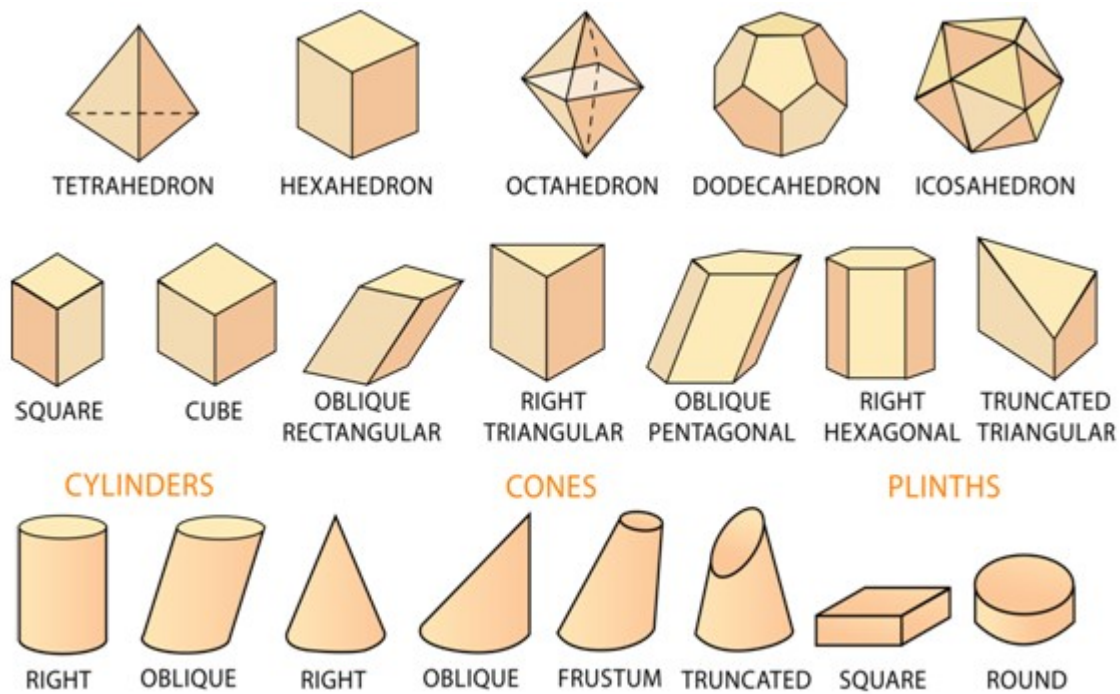

Figure 2 surfaces of few simple solids .

### Primitive geometric forms

The shapes of objects are formed from primitive geometric forms . These are

1. Point
1. Line
2. Plane
3. Solid
4. Doubly curved surface and object
5. Warped surface

The basic 2-D geometric primitives, from which other more complex geometric forms are derived.

- Points,
- Lines,
- Circles, and
- Arcs

### Point

A point is a theoretical location that has neither width, height, nor depth and describes exact location in space. A point is represented in technical drawing as a small cross made of dashes that are approximately 3 mm long. As shown in figure 4, a point is used to mark the locations of centers and loci, the intersection ends, middle of entities

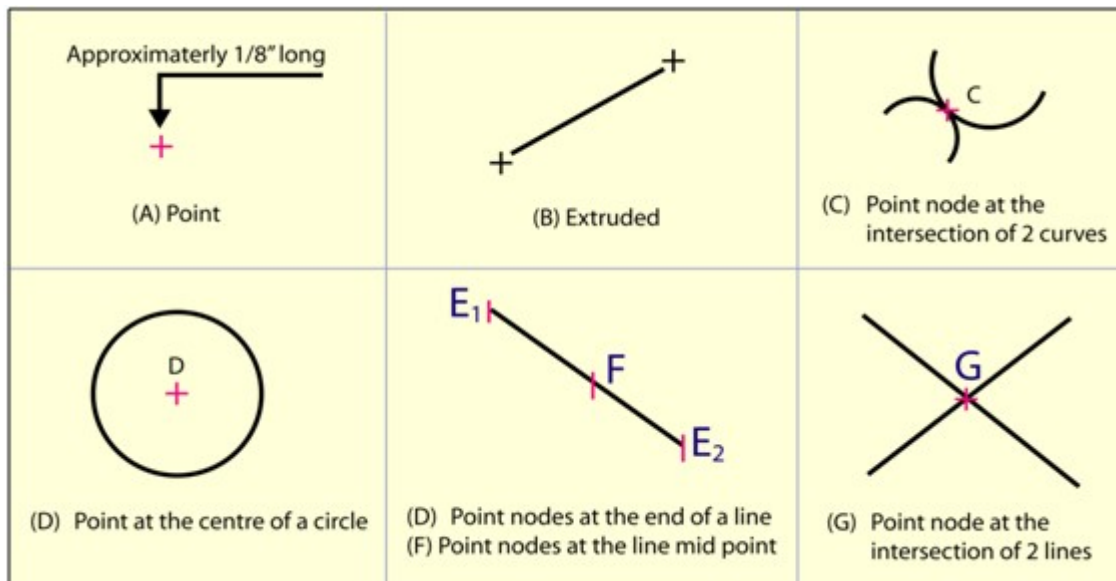

Figure 4. shows the various use of points.

## Line

A line is a geometric primitive that has length and direction, but no thickness. Lines may be straight, curved or a combination of these. As shown in figure 5, lines have few important relationship or conditions, such as parallel, intersecting, and tangent. Lines can be of specific length or non-specific length. A Ray is a sStraight line that extends to infinity from a specified point.

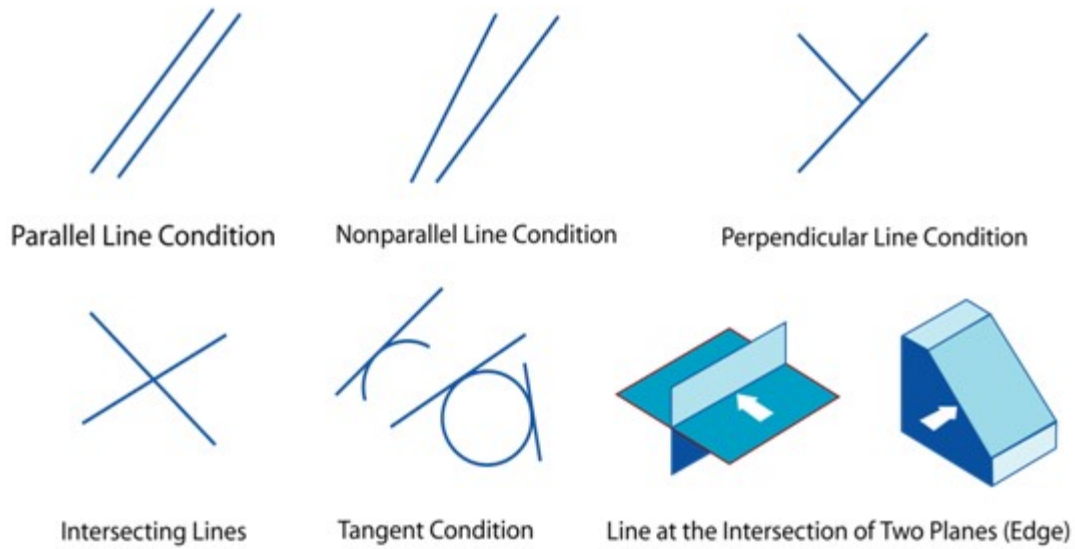

Figure 5. Relationship of one line to another line or arc

### Bisecting a line

The procedure of bisecting a given line AB is illustrated in figure 6. With A as centre and radius equal to higher than half AB, draw two arcs. With B as centre and with the same radius draw another arc intersecting the previous arcs. The line joining the intersection points is the perpendicular bisector of the line AB.

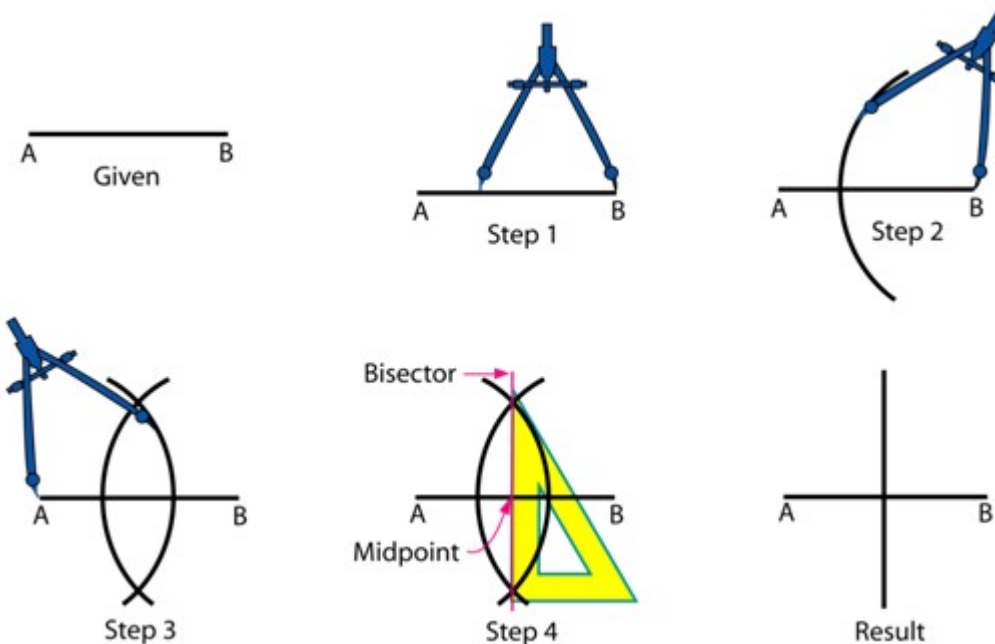

Figure 6. Illustrates the method of bisecting a line

## Dividing a line into equal parts

The method of dividing a line MO into equal number of parts is illustrated in figure 7.

- Draw a line MO at any convenient angle (preferably an acute angle) from point M.
- From M and along MO, cut off with a divider equal divisions (say three) of any convenient length.
- Draw a line joining ON.
- Draw lines parallel to MO through the remaining points on line MO.

The intersection of these lines with line MN will divide the line into (three) equal parts.

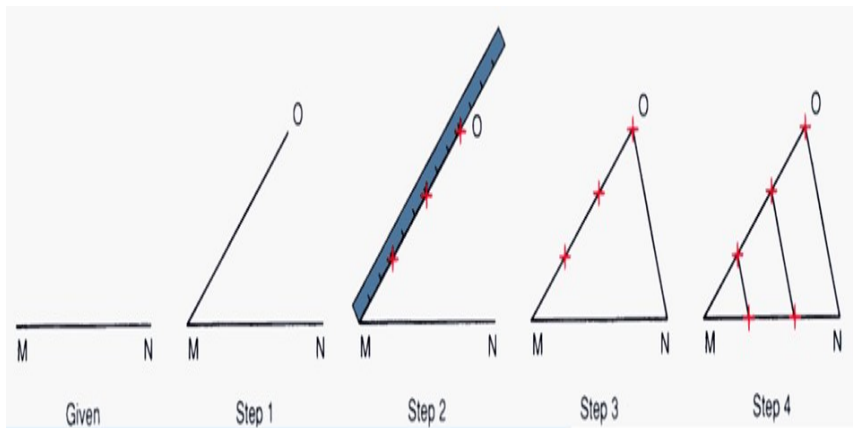

Figure 7. Dividing a line in to equal number of parts.

## Construction of Regular Polygon of given length AB

To construct a regular polygon with length of edge AB us shown in figure 1.

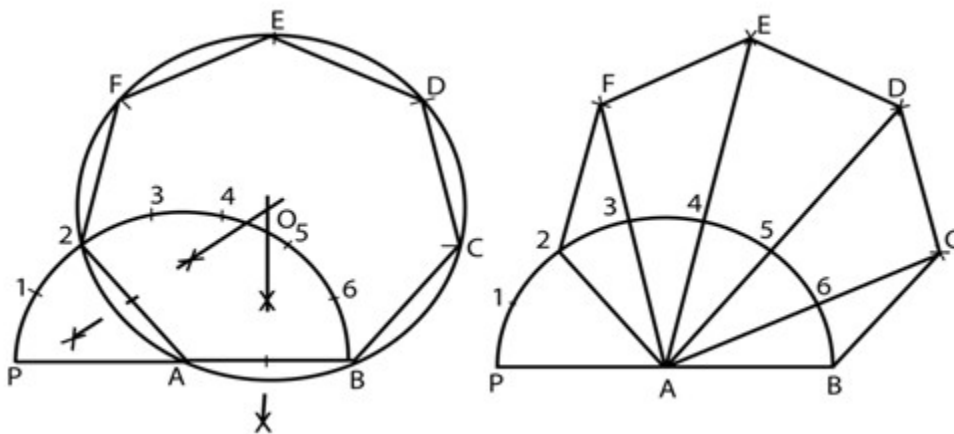

Figure 1. Construction of a regular polygon with a given length of edge.

- Draw a line of length AB. With A as centre and radius AB, draw a semicircle.

- With the divider, divide the semicircle into the number of sides (example of number of side 7 is shown in figure 1) of the polygon.
- Draw a line joining A with the second division-point 2.
- The perpendicular bisectors of A2 and AB meet at O. Draw a circle with centre O and radius OA.
- With length A2, mark points F, E, D & C on the circumferences starting from 2 (*Inscribe circle method*)
- With centre B and radius AB draw an arc cutting the line A6 produced at C. Repeat this for other points D, E & F (*Arc method*)

### General method of drawing any polygon

A more general method of drawing any polygon with a given length of edge is shown in figure 2.

- Draw AB = given length of polygon
- At B, Draw BP perpendicular & = AB
- Draw Straight line AP
- With center B and radius AB, draw arc AP.
- The perpendicular bisector of AB meets the line AP and arc AP in 4 and 6 respectively.
- Draw circles with centers as 4, 5, & 6 and radii as 4B, 5B, & 6B and inscribe a square, pentagon, & hexagon in the respective circles.
- Mark point 7, 8, etc with 6-7, 7-8, etc. = 4-5 to get the centers of circles of heptagon and octagon, etc.

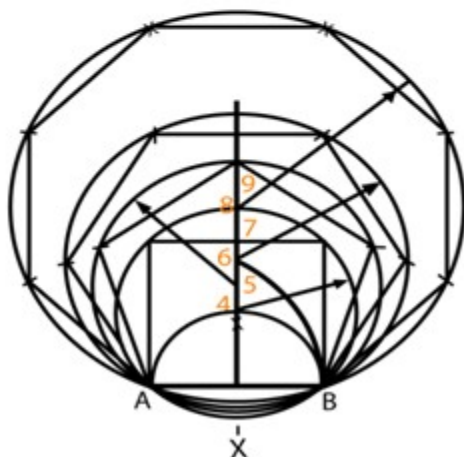
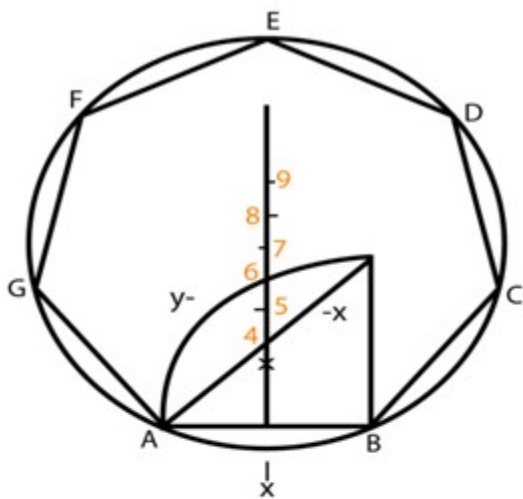

Figure 2 Drawing any polygon with a given length of edge

### Inscribe a circle inside a regular polygon

The method of inscribing a circle inside a regular polygon is illustrated in figure 3.

1. Bisect any two adjacent internal angles of the polygon.
2. From the intersection of these lines, draw a perpendicular to any one side of the polygon (say OP).
3. With OP as radius, draw the circle with O as center

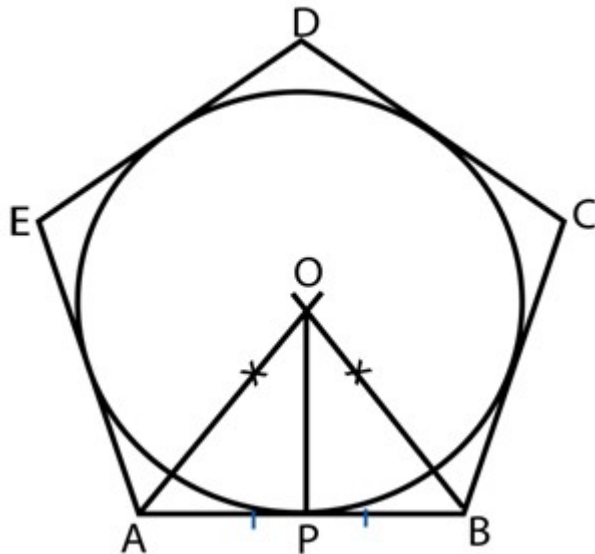

Figure 3 Inscribing a circle inside a regular polygon

### Inscribe a regular polygon of any number of sides (say $n = 5$ ), in a circle

Figure 4 shows the method of inscribing a regular polygon of any number of sides.

- Draw the circle with diameter AB.
- Divide AB in to “n” equal parts
- Number them.
- With center A & B and radius AB, draw arcs to intersect at P.
- Draw line P2 and produce it to meet the circle at C.
- AC is the length of the side of the polygon.

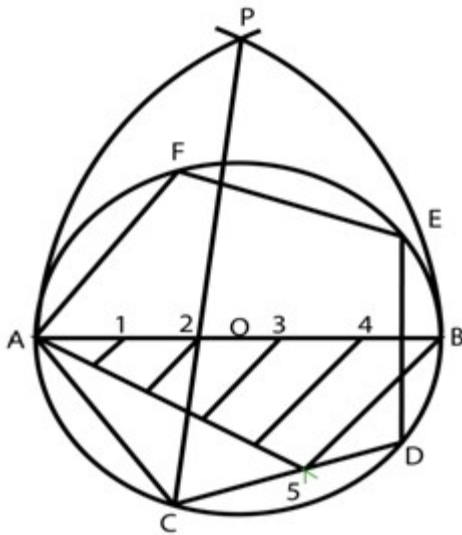

Figure 4 Inscribing a regular polygon of any number of sides.

### Conic curves (conics)

Curves formed by the intersection of a plane with a right circular cone. e.g. Parabola, hyperbola and ellipse. Right circular cone is a cone that has a circular base and the axis is inclined at 90° to the base and passes through the center of the base. Conic sections are always "smooth". More precisely, they never contain any inflection points. This is important for many applications, such as aerodynamics, civil engineering, mechanical engineering, etc. Figure 1. Shows a right cone and the various conic curves that can be obtained from a cone by sectioning the cone at various conditions.

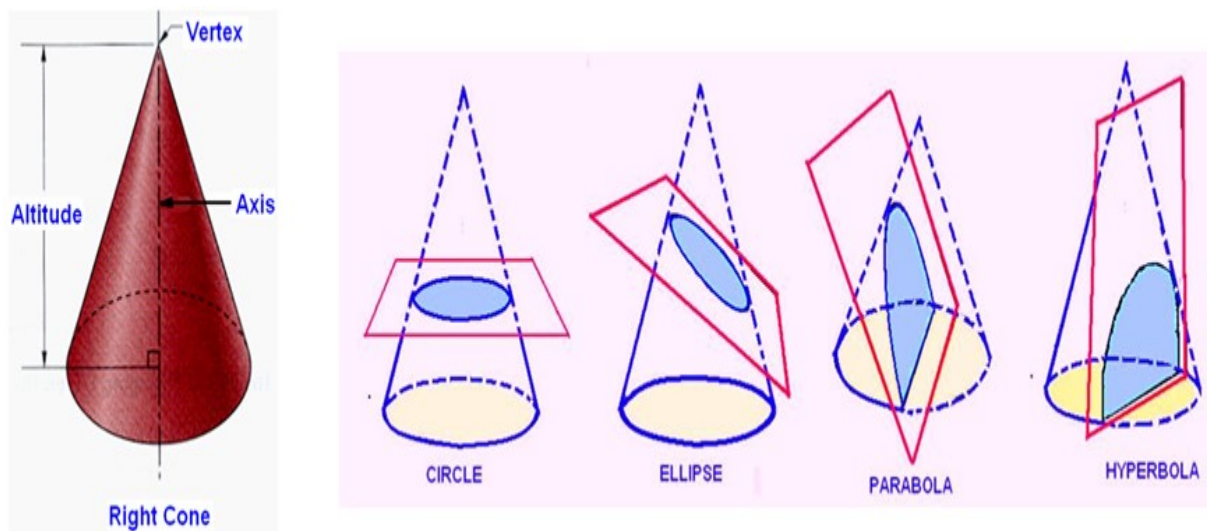

Figure 1. Shows a right cone and the various conic curves that can be obtained from a cone by sectioning the cone at various conditions.

### Conic

Conic is defined as the locus of a point moving in a plane such that the ratio of its distance from a fixed point and a fixed straight line is always constant.

- Fixed point is called Focus
- Fixed line is called Directrix

This is illustrated in figure 2.

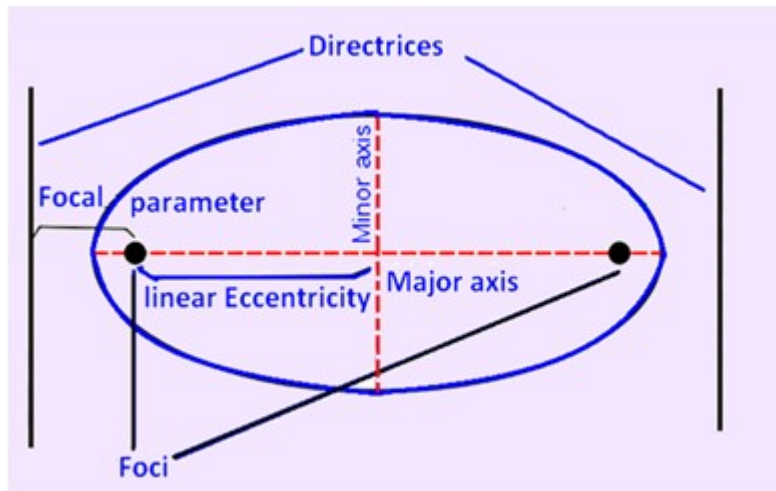

Figure 2. illustrates the directrices and foci of a conic curve.

$$\text{Eccentricity} = \frac{\text{Distance of the point from the focus}}{\text{Distance of the point from the directrix}}$$

When eccentricity

$< 1 \rightarrow$  Ellipse

$= 1 \rightarrow$  Parabola

$> 1 \rightarrow$  Hyperbola

eg. when  $e=1/2$ , the curve is an Ellipse, when  $e=1$ , it is a parabola and when  $e=2$ , it is a hyperbola. Figure 3 shows the ellipse, parabola and hyperbola.

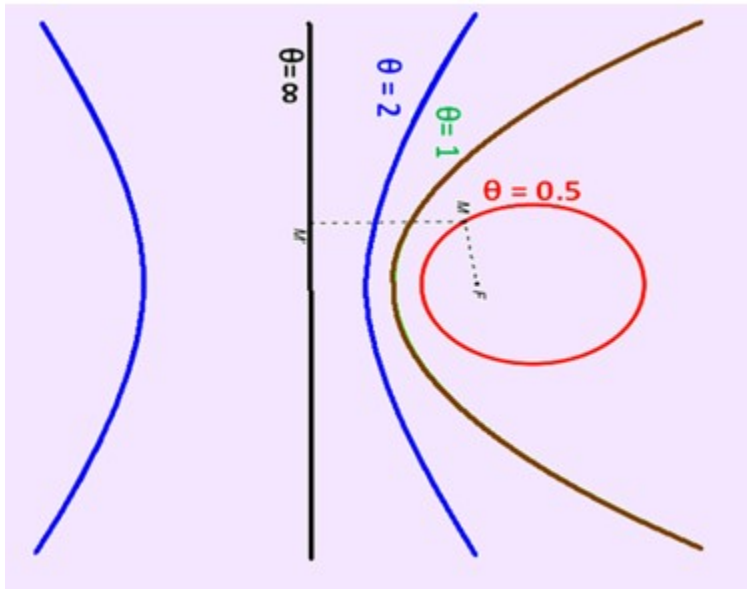

Figure 3 shows the relationship of eccentricity with different conic curves.

## Ellipse

Referring to figure 4, an ellipse can be defined in the following ways.

- An ellipse is obtained when a section plane, inclined to the axis of the cone, cuts all the generators of the cone.
- An ellipse is the set of all points in a plane for which the sum of the distances from the two fixed points (the foci) in the plane is constant
- An ellipse is also defined as a curve traced by a point, moving in a plane such that the sum of its distances from two fixed points is always the same.

Construction of Ellipse

1. When the distance of the directrix from the focus and eccentricity is given.
2. Major axis and minor axis is given.
3. Arc of circle method
4. Concentric circle method
5. Oblong method
6. Loop of the thread method

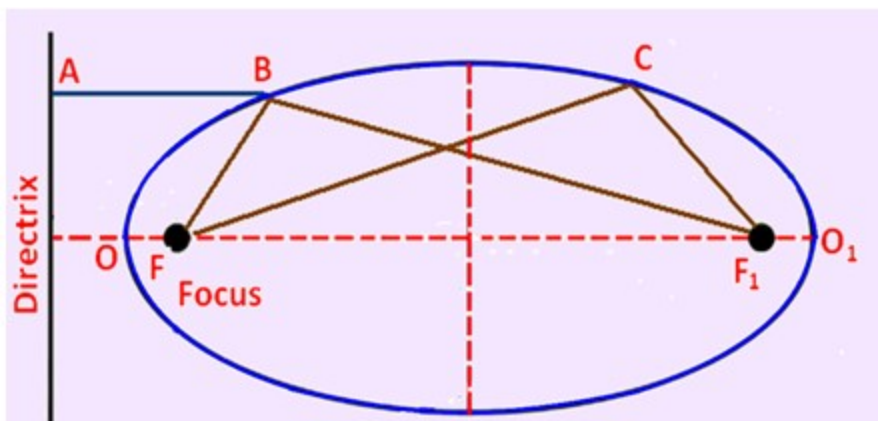

Figure 4. illustrating an ellipse.

### Focus-Directrix or Eccentricity Method

Given : the distance of focus from the directrix and eccentricity

Figure 5. shows the method of drawing an ellipse if the distance of focus from the directrix is 80 mm and the eccentricity is  $3/4$ .

1. Draw the directrix AB and axis CC'
2. Mark F on CC' such that CF = 80 mm.
3. Divide CF into 7 equal parts and mark V at the fourth division from C. Now,  $e = FV / CV = 3/4$ .
4. At V, erect a perpendicular VB = VF. Join CB. Through F, draw a line at  $45^\circ$  to meet CB produced at D. Through D, drop a perpendicular DV' on CC'. Mark O at the midpoint of V-V'.

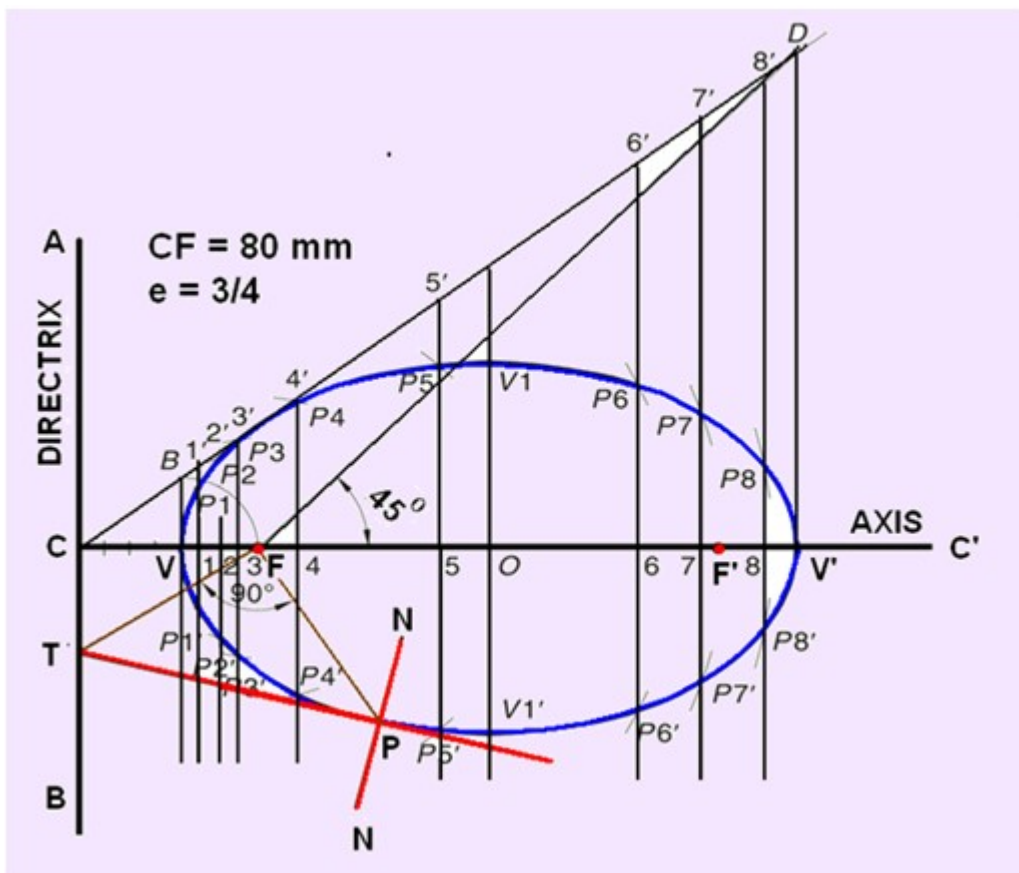

Figure 5. drawing an ellipse if the distance of focus from the directrix and the eccentricity is given

5. With F as a centre and radius =  $1-1'$ , cut two arcs on the perpendicular through 1 to locate P1 and P1'. Similarly, with F as centre and radii =  $2-2'$ ,  $3-3'$ , etc., cut arcs on the corresponding perpendiculars to locate P2 and P2', P3 and P3', etc. Also, cut similar arcs on the perpendicular through O to locate V1 and V1'.

6. Draw a smooth closed curve passing through V, P1, P2, P3, ..., V1, ..., V', ..., V1', ... P3', P2', P1'.

7. Mark F' on CC' such that  $V'F' = VF$ .

An ellipse is also the set of all points in a plane for which the sum of the distances from the two fixed points (the foci) in the plane is constant. This is clear from figure 6.

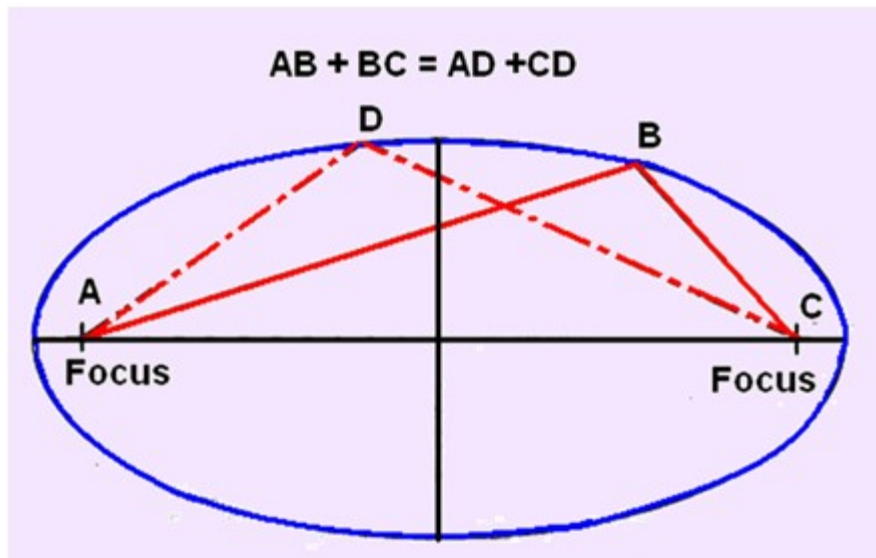

- 5.
6. Figure 6. Another definition of ellipse

### **Arcs of Circle Method**

The arc of circle method of drawing an ellipse is generally used when (i) the major axes and minor axis are known, and (ii) the major axis and the distance between the foci are known. The method of drawing the ellipse by the arcs of circle method is as follows and is shown in figure 7.

Draw AB & CD perpendicular to each other as the major diameter minor diameter respectively.

With centre as C or D, and half the major diameter as radius draw arcs to intersect the major diameter to obtain the foci at X and Y.

Mark a number of points along line segment XY and number them. Points need not be equidistant.

Set the compass to radius B1 and draw two arcs, with Y as center. Set the compass to radius A1, and draw two arcs with X as center. Intersection points of the two arcs are points on the ellipse. Repeat this step for all the remaining points. Use the French curve to connect the points, thus drawing the ellipse.

### **Constructing an Ellipse (Concentric Circle Method)**

Concentric circle method is used when the major axis and minor axis of the ellipse is given. This method is illustrated in figure 8 and discussed below:

- With center C, draw two concentric circles with diameters equal to major and minor diameters of the ellipse. Draw the major and minor diameters.
- Construct a line AB at any angle through C. Mark points D and E where the line intersects the smaller circle.
- From points A and B, draw lines parallel to the minor diameter. Draw lines parallel to the major diameter through D & E.
- The intersection of the lines from A and D is point F, and from B and E is point G. Points F & G lies on the ellipse.

- Extend lines FD & BG and lines AF and GE to obtain two more points in the other quadrants.
- Repeat steps 2-6 to create more points in each quadrant and then draw a smooth curve through the points.
- With center C, draw two concentric circles with diameters equal to major and minor diameters of the ellipse. Draw the major and minor diameters.

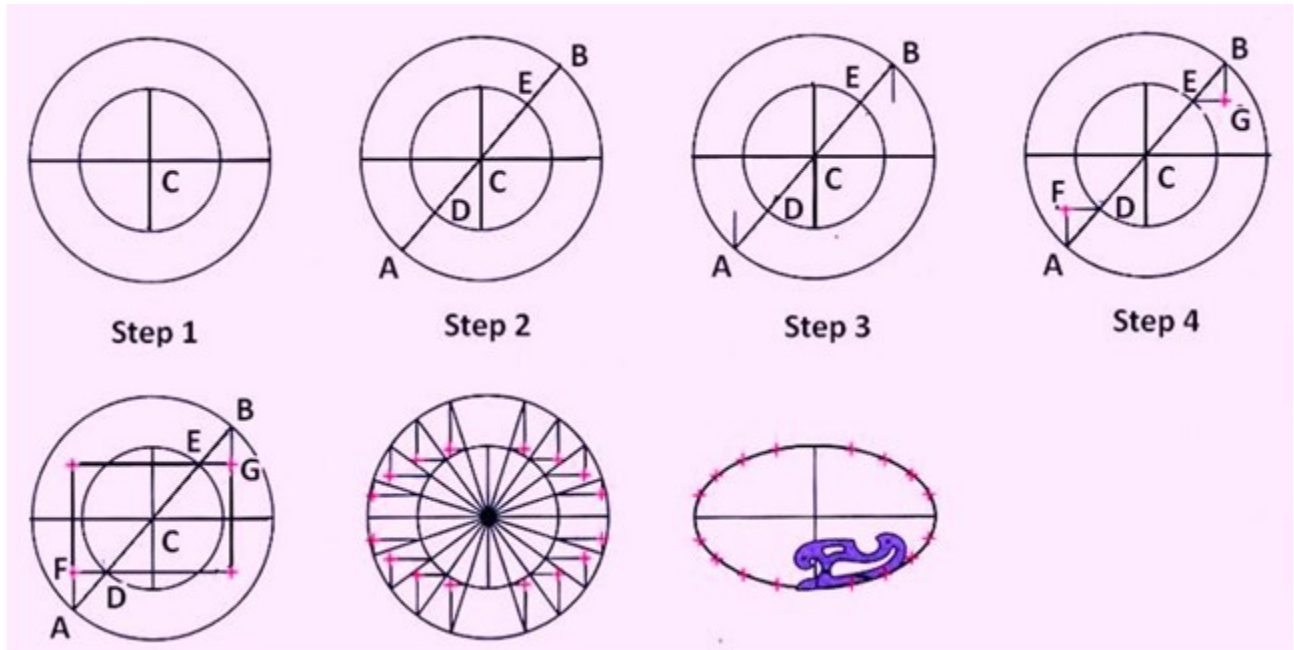

Figure 8. Concentric circle method of drawing ellipse

### Drawing Tangent and Normal to any conic

When a tangent at any point on the curve (P) is produced to meet the directrix, the line joining the focus with this meeting point (FT) will be at right angle to the line joining the focus with the point of contact (PF).

The normal to the curve at any point is perpendicular to the tangent at that point.

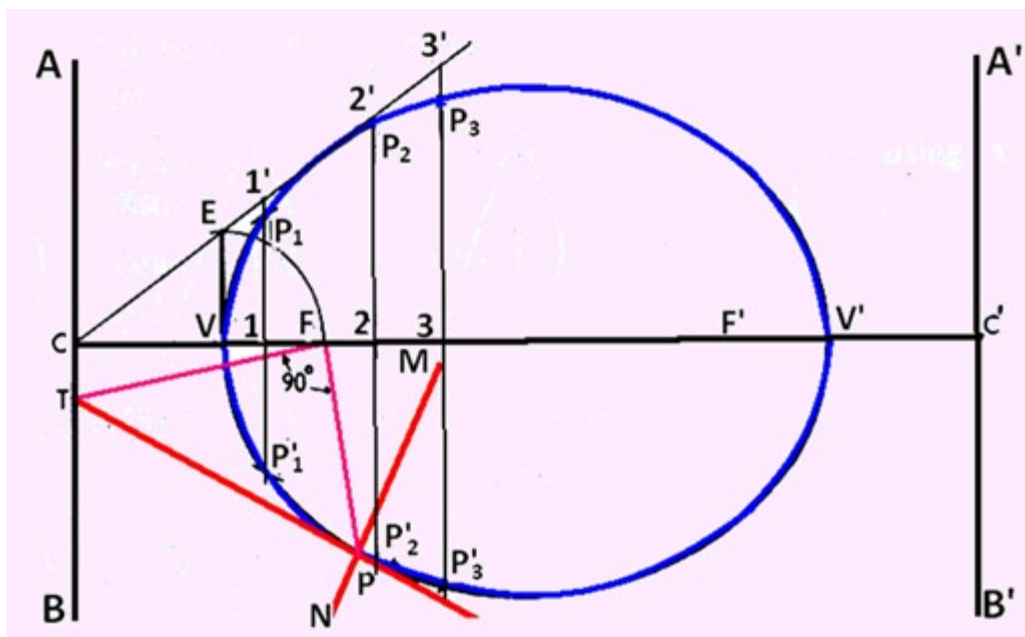

Figure 9. The method of drawing tangent and normal to any conic section at a particular point.

## Parabola

A parabola is obtained when a section plane, parallel to one of the generators cuts the cone. This is illustrated in figure 1.

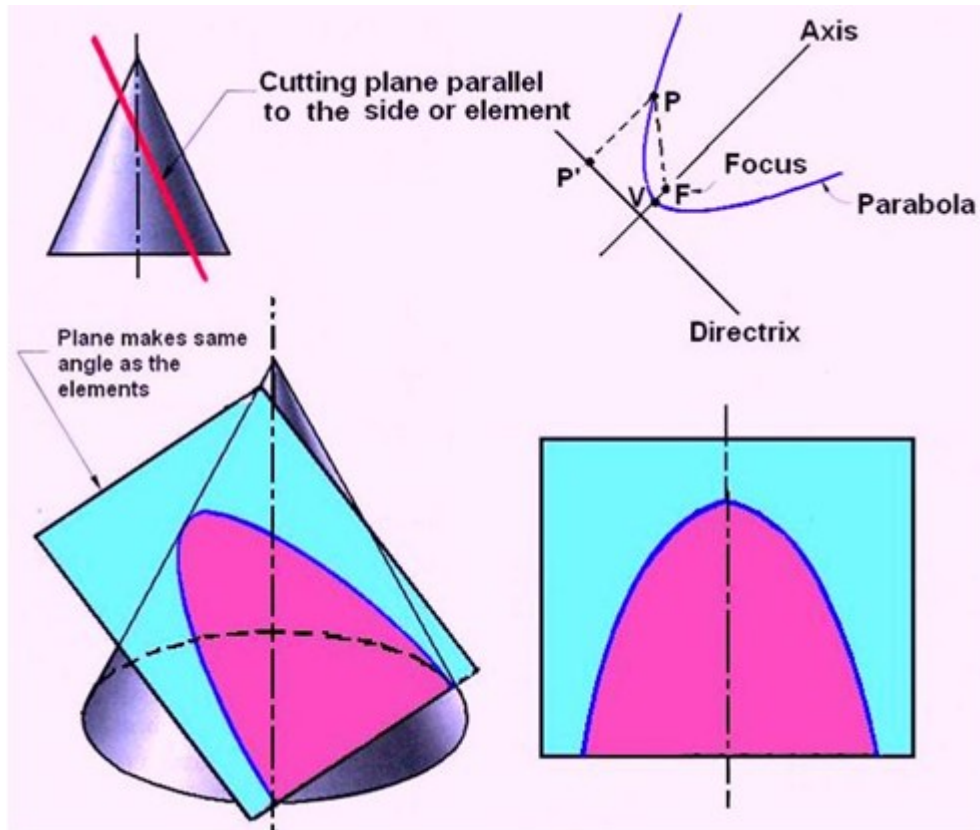

Figure 1. Obtaining a parabola from a cone.

## Parabola

### Constructing a Parabola (Eccentricity Method)

The method of constructing a parabola by the eccentricity method where the distance of the focus from the directrix is 60 mm is shown in figure 2 and explained below.

1. Draw directrix AB and axis CC' as shown.
2. Mark F on CC' such that CF = 60 mm.
3. Mark V at the midpoint of CF. Therefore,  $e = VF/VC = 1$ .
4. At V, erect a perpendicular VB = VF. Join CB.
5. Mark a few points, say, 1, 2, 3, ... on VC' and erect perpendiculars through them meeting CB produced at 1', 2', 3', ...

- With F as a centre and radius =  $1-1'$ , cut two arcs on the perpendicular through 1 to locate P1 and P1'. Similarly, with F as a centre and radii =  $2-2'$ ,  $3-3'$ , etc., cut arcs on the corresponding perpendiculars to locate P2 and P2', P3 and P3', etc.
- Draw a smooth curve passing through V, P1, P2, P3 ... P3', P2', P1'.

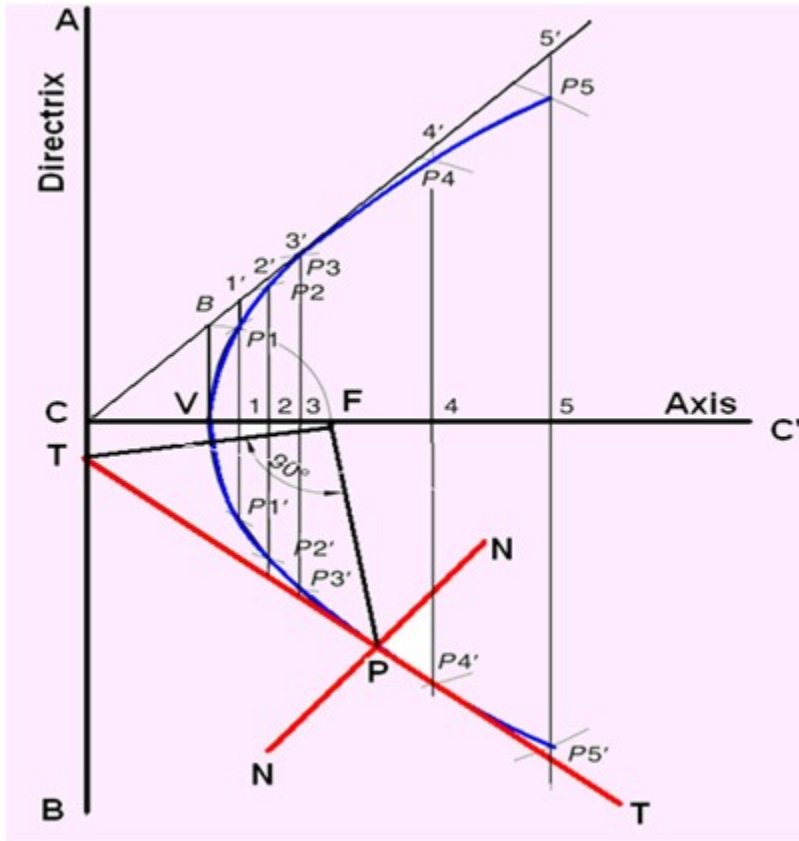

Figure 2. Construction of parabola by eccentricity method.

### Constructing a Parabola (Parallelogram Method)

Parabola can also be constructed by parallelogram method. This is illustrated by the example below and shown in figure 3.

Example: Draw a parabola of base 100 mm and axis 50 mm if the axis makes  $70^\circ$  to the base.

- Draw the base  $RS = 100$  mm and through its midpoint K, draw the axis  $KV = 50$  mm, inclined at  $70^\circ$  to RS. Draw a parallelogram RSMN such that SM is parallel and equal to KV.
- Divide RN and RK into the same number of equal parts, say 5. Number the divisions as 1, 2, 3, 4 and 1', 2', 3', 4', starting from R.
- Join V-1, V-2, V-3 and V-4. Through 1', 2', 3' and 4', draw lines parallel to KV to meet V-1 at P1, V-2 at P2, V-3 at P3 and V-4 at P4, respectively.
- Obtain P5, P6, P7 and P8 in the other half of the rectangle in a similar way. Alternatively, these points can be obtained by drawing lines parallel to RS through P1, P2, P3 and P4. For example, draw P1-P8 such that  $P1-x = x-P8$ . Join P1, P2, P3 ... P8 to obtain the parabola.

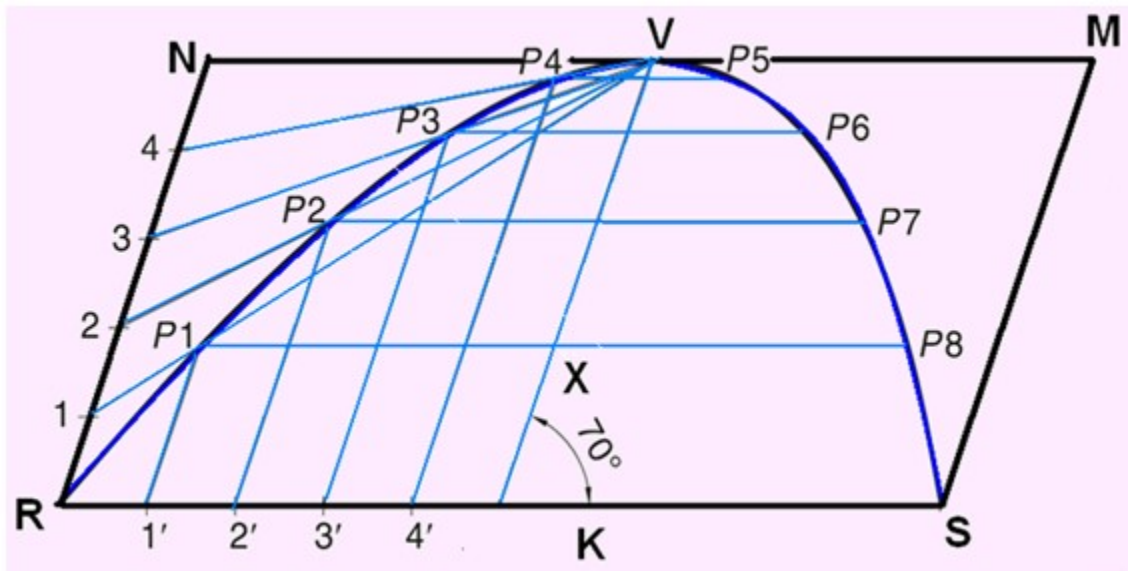

Figure 3. Construction of parabola by parallelogram method.

### Tangent Method

This method can be used when the base and the axis, or base and the inclinations of tangents at open ends of the parabola with the base are given. The method is shown in figure 4.

This method can be used when the base and the axis, or base and the inclinations of tangents at open ends of the parabola with the base are given. The method is shown in figure 4.

Draw the line AB representing the base of the parabola.

Draw the Axis EF representing the height of the parabola.

Produce EF to O such that  $EF = OF$

Join OA and OB

Divide OA and OB into the same number of parts say 8

Mark the division points as shown

Draw lines joining 1 to 1', 2 to 2', 3 to 3', etc.

Draw a curve starting from A and tangent to the lines 1-1', 2-2', 3-3', etc, which is the required parabola.

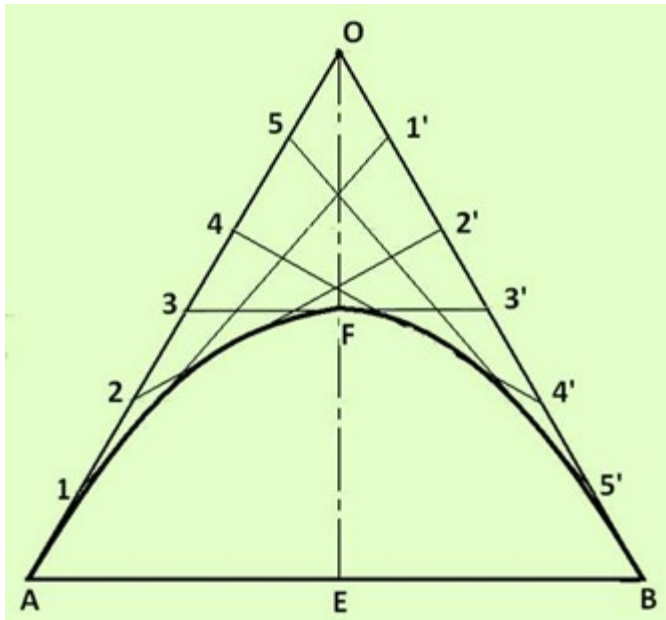

Figure 4. Tangent method of drawing a parabola.

### Hyperbola

A Hyperbola is obtained when a section plane, parallel/inclined to the axis cuts the cone on one side of the axis. This is illustrated in figure 1.

A Rectangular Hyperbola is obtained when a section, parallel to the axis cuts the cone on one side of the axis.

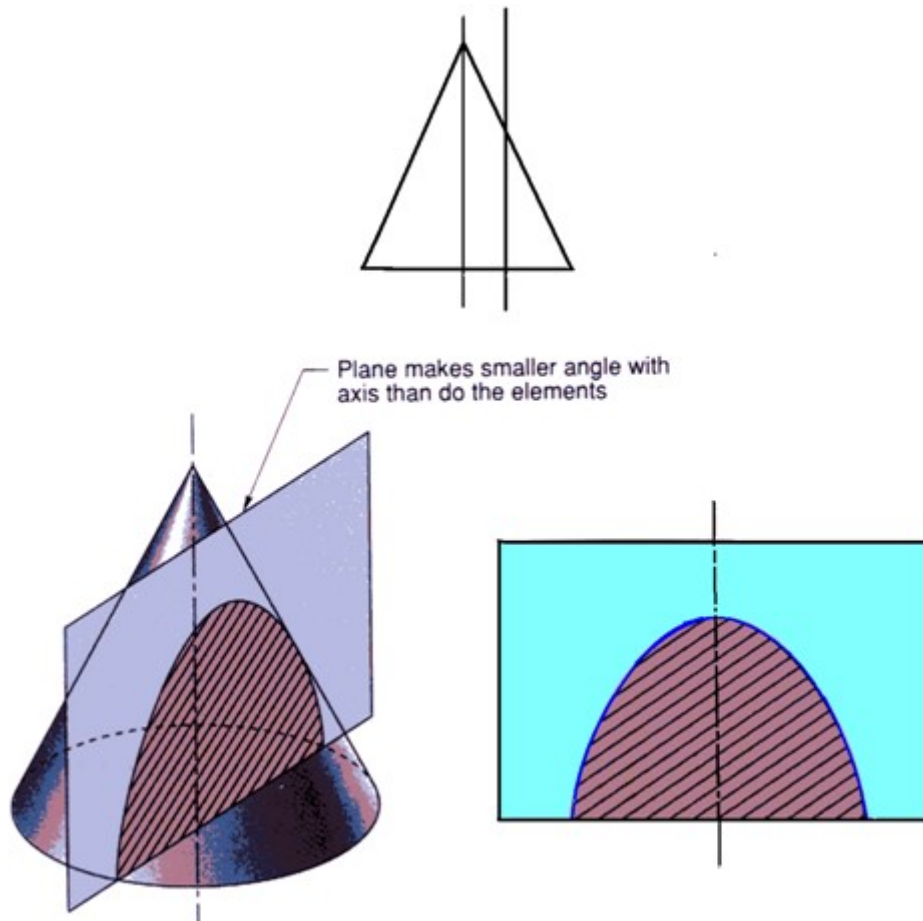

Figure 1. illustration of a hyperbola.

### Constructing a Hyperbola (Eccentricity Method)

Construction of hyperbola by eccentricity method is similar to ellipse and parabola  
 Construction of a hyperbola by eccentricity method is illustrated in figure 2, where the eccentricity,  $e = 3/2$  and the distance of the focus from the directrix = 50 mm.

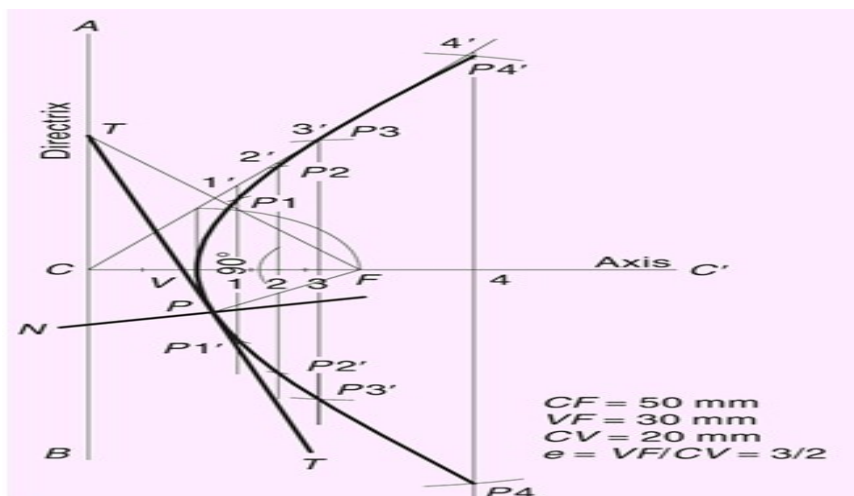
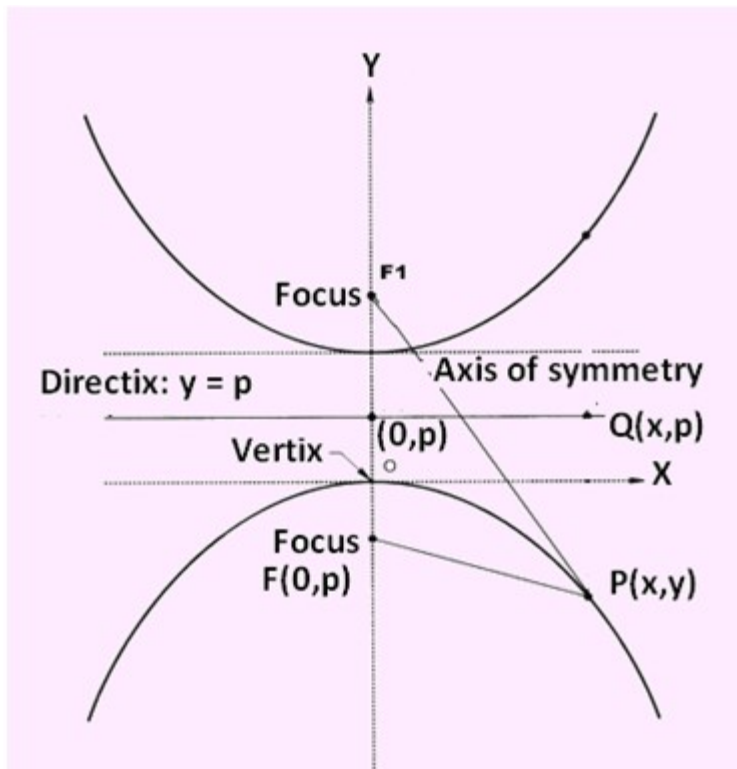

Fig. 2

A hyperbola is mathematically defined as the set of points in a plane whose distances from two fixed points called foci, in the plane have a constant difference.



### Constructing a Hyperbola

Hyperbola can also be construct if the distance between Foci and Distance between vertices are known. This is illustrated in figure 3.

Draw the axis of symmetry and construct a perpendicular through the axis. Locate focal point  $F$  equidistant from the perpendicular and on either side of it. Locate points  $A$  and  $B$  on the axis equidistant from the perpendicular.

$AB$  is the distance between vertices.

With  $F$  as center and radius  $R_1$ , and draw the arcs. With  $R_1 + AB$ , radius, and  $F$  as center, draw a second set of arcs. The intersection of the two arcs on each side of the perpendicular are points on the hyperbola.

Select a new radius  $R_2$  and repeat step 2. Continue this process until several points on the hyperbola are marked

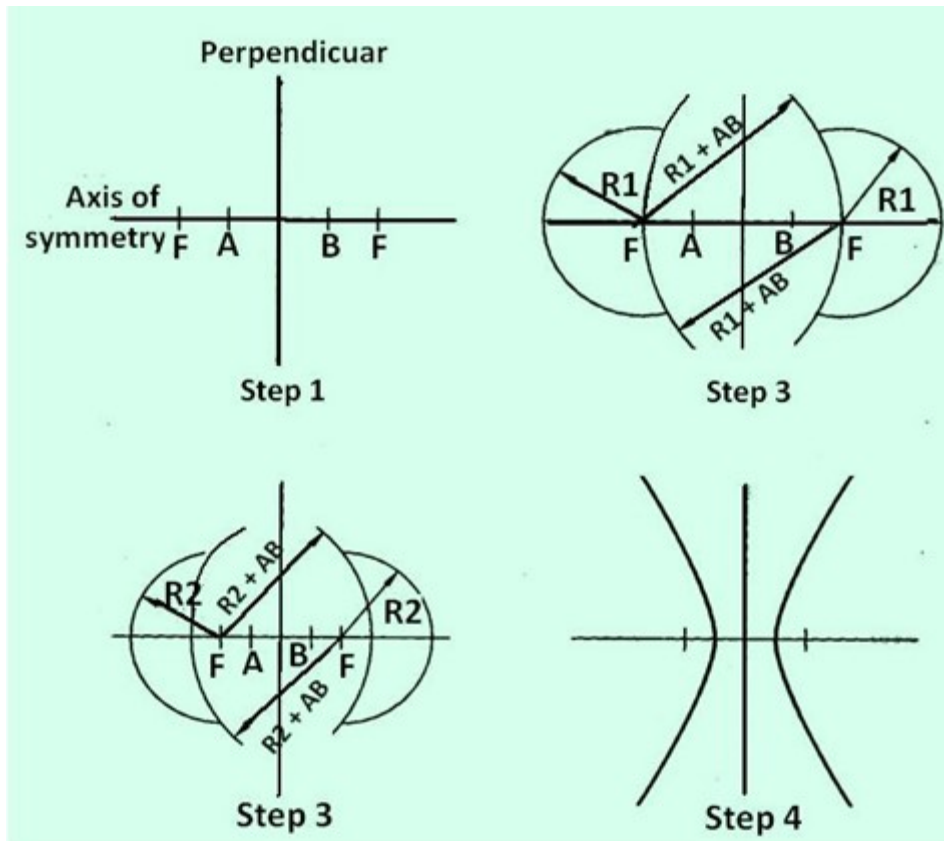

Figure 3. Construction of a hyperbola

### Spirals

A spiral is a curve traced by a point moving along a line in one direction, while the line is rotating in a plane about one of its ends or any point on it.

e.g. Turbine casing, spiral casings. etc. In other words it is the locus of a point which moves around a centre, called the pole, while moving towards or away from the centre.

The point which generates the curve is called the generating point or tracing point. The point will move along a line called the radius vector while the line itself rotates about one of its end points. Generally for engineering applications two types of spirals are encountered. They are:

- i. **Archimedean Spiral:** The curve traced out by a point moving in such a way that its movement towards or away from the pole is uniform with the increase in the vectorial angle from the starting line.

Applications include teeth profile of helical gears, profile of cams, etc. A typical Archimedean spiral is shown in figure 1.

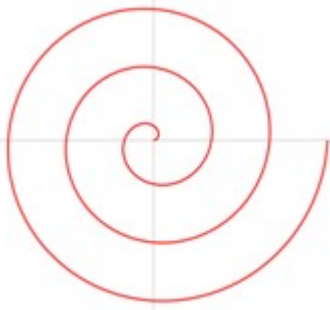

Figure 1. A typical Archimedean Spiral

- ii. **Logarithmic Spiral:** The ratio of the lengths of consecutive radius vectors enclosing equal angles is always constant.  
 i.e. the values of the vectorial angles are in arithmetic progression and the corresponding values of radius vectors are in geometric progression. A typical logarithmic spiral is shown in figure 2.

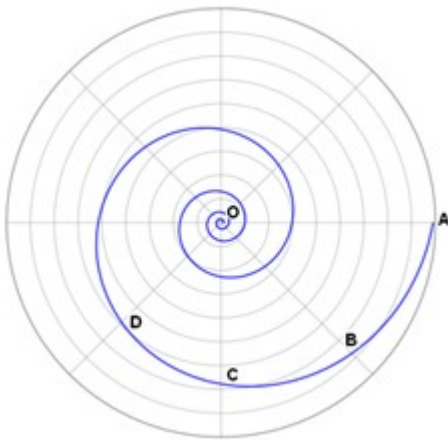

Figure 2 A typical Logarithmic spiral

### Archimedean Spiral

The steps used to obtain an Archimedean spiral is shown in figure 3 with the help of the problem given below.

**Problem:** A point moves away from the pole O and reaches a distance of 50 mm while moving around it once.

Its movement from O is uniform with its movement around. Draw the curve.

**Solution:** Draw a circle with diameter 50 mm and divide it into a number of equal segments, (say six). Label the intersections between the radius and the circle as points 1 through 6. Divide radius 0-6 into the same number of equal parts (i.e. six).

Mark points on the radius as 1', 2', etc.

With O as the center, draw an arc of radius 01', between 06 & 01. Mark the point of intersection of the arc with radius 01.

Then draw an arc of radius 02', between 06 & 02. Repeat this process until arcs have been drawn from all the points on the radius 0-6.

Using French curve, connect the intersection points in the order, they were marked i.e. point on 01, point on 02 radius, point on 03....

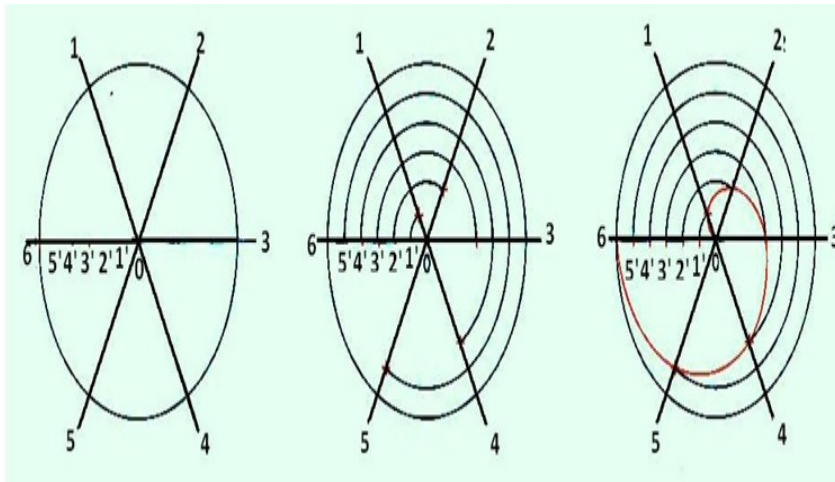

Figure 3. Steps in drawing an Archemidian spiral

### Logarithmic spiral

In logarithmic spiral, the ratio of the lengths of consecutive radius vectors enclosing equal angles always remains constant. i.e. the values of vectorial angles are in arithmetical progression. The corresponding values of radius vectors are in geometric progression.

The construction of a logarithmic spiral is illustrated in figure 4 as solution to the following problem.

Problem: Ratio of lengths of radius vectors enclosing angle of  $30^\circ = 6:5$ . Final radius vector of the spiral is 90 mm. Draw the spiral.

Solution:

Draw line AB and AC inclined at  $30^\circ$ .

On line AB, mark A-12 = 90 mm.

A as center and A12 radius draw an arc to cut AC at 12'.

Mark A11 (=  $5/6$  of A12) on AB. Join 12' and 11.

Draw an arc with A as center and A11 radius to cut the line AC at 11'.

Draw a line through 11' parallel to 12'-11 to cut AB at 10.

Repeat the procedure to obtain points 9', 8', 7'...0.

OP12 = A12', OP11 = A11'....

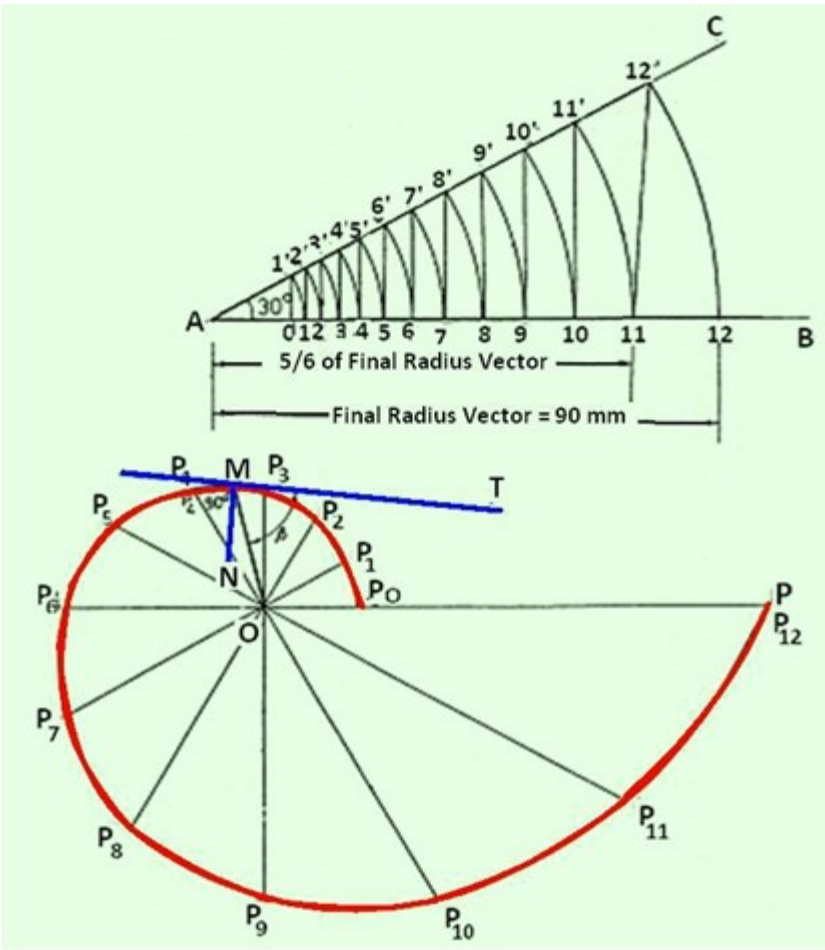

Figure 4. Logarithmic spiral

**Normal and tangent to an Archimedean spiral.**

The normal to an Archimedean Spiral at any point is the hypotenuse of the right angles triangle having the other two sides equal to the length of the radius vector at that point and the constant of the curve. The constant of the curve is equal to the difference between the length of any two radii divided by the circular measure of the angle between them.

The steps followed to draw the normal and tangent to a spiral at any point N is illustrated in figure 5.

Draw the radius vector ON

Draw OM perpendicular to ON and length equal to the constant of the curve.

Join MN

MN is the normal at point N

Draw PQ perpendicular to MN to obtain the tangent at N.

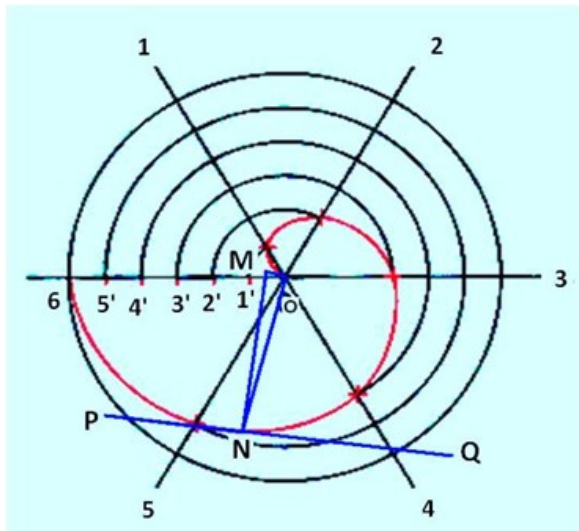

Figure 5. Drawing a tangent and normal to the spiral at any point.

### Roulettes

Roulettes are curves generated by the rolling contact of one curve or line on another curve or line. There are various types of roulettes. The most common types of roulettes used in engineering practice are: Cycloids, trochoids, and Involutés. Assume a wheel is rolling along a surface without slipping. Trace the locus of a point on the wheel. Depending on the position of the point and the geometry of the surface on which the wheel rolls, different curves are obtained. Table 1 provides the general classification of roulettes.

**Cycloid:** Cycloid is generated by a point on the circumference of a circle rolling along a straight line without slipping.

**Epicycloid:** The cycloid is called Epicycloid when the generating circle rolls along the circumference of another circle outside it.

**Hypocycloid:** Hypocycloid is obtained when the generating circle rolls along the circumference of another circle but inside it. Table 1 Classification of Cycloidal curve

	Generating Circle			
		On the directing line	Outside the directing line	Inside the directing line
Generating point	On the generating circle	Cycloid	Epicycloid	Hypocycloid
	Outside the generating circle	Superior trochoid	Superior epitrochoid	Superior Hypotrochoid
	Inside the generating circle	Inferior trochoid	Inferior epitrochoid	Inferior hypotrochoid

### Cycloid

A Cycloid is generated by a point on the circumference of a circle rolling along a straight line

without slipping. The rolling circle is called the Generating circle. The straight line is called the Directing line or Base line

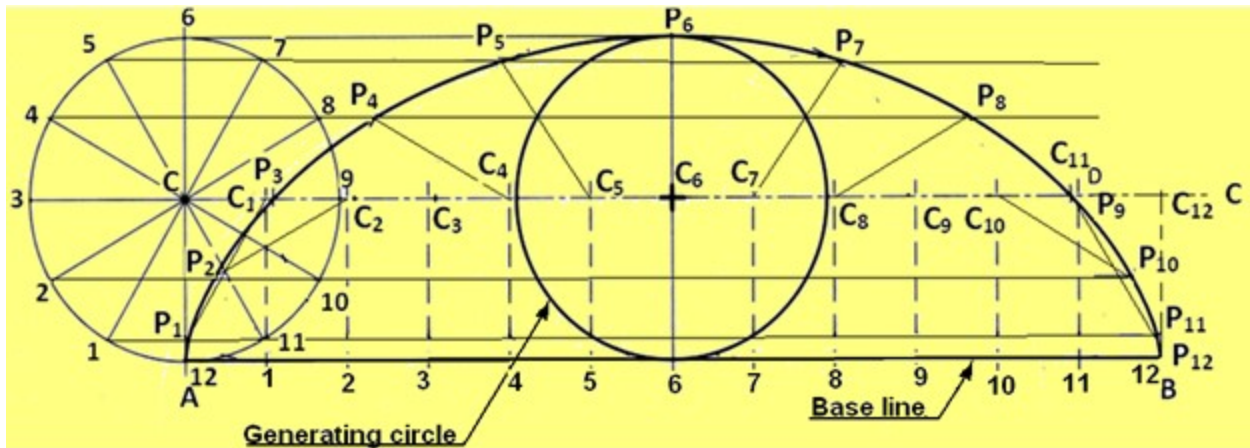

Figure 1 illustrates the procedure for drawing a cycloid.

Generating circle has its center at C and has a radius of C-P'. Straight line PP' is equal in length to the circumference of the circle and is tangent to the circle at point P'. Divide the circle into a number of equal segments, such as 12. Number the intersections of the radii and the circle.

From each point of intersection on the circle, draw a construction line parallel to line PP' and extending up to line P'C'. Divide the line CC' into the same number of equal parts, and number them. Draw vertical lines from each point to intersect the extended horizontal centerline of the circle. Label each point as C1, C2, C3, .... C12.

Using point C1 as the center and radius of the circle C-P', draw an arc that intersects the horizontal line extended from point 1 at P1. Set the compass at point C2, then draw an arc that intersects the horizontal line passing through point 2 at P2. Repeat this process using points C3, C4, .... C12, to locate points along the horizontal line extended from points 3, 4, 5, etc.. Draw a smooth curve connecting P1, P2, P3, etc to form the cycloid.

### **Epicycloid**

Epicycloid is the curve generated by a point on the circumference of a circle which rolls without slipping along another circle outside it. This is illustrated in figure 2.

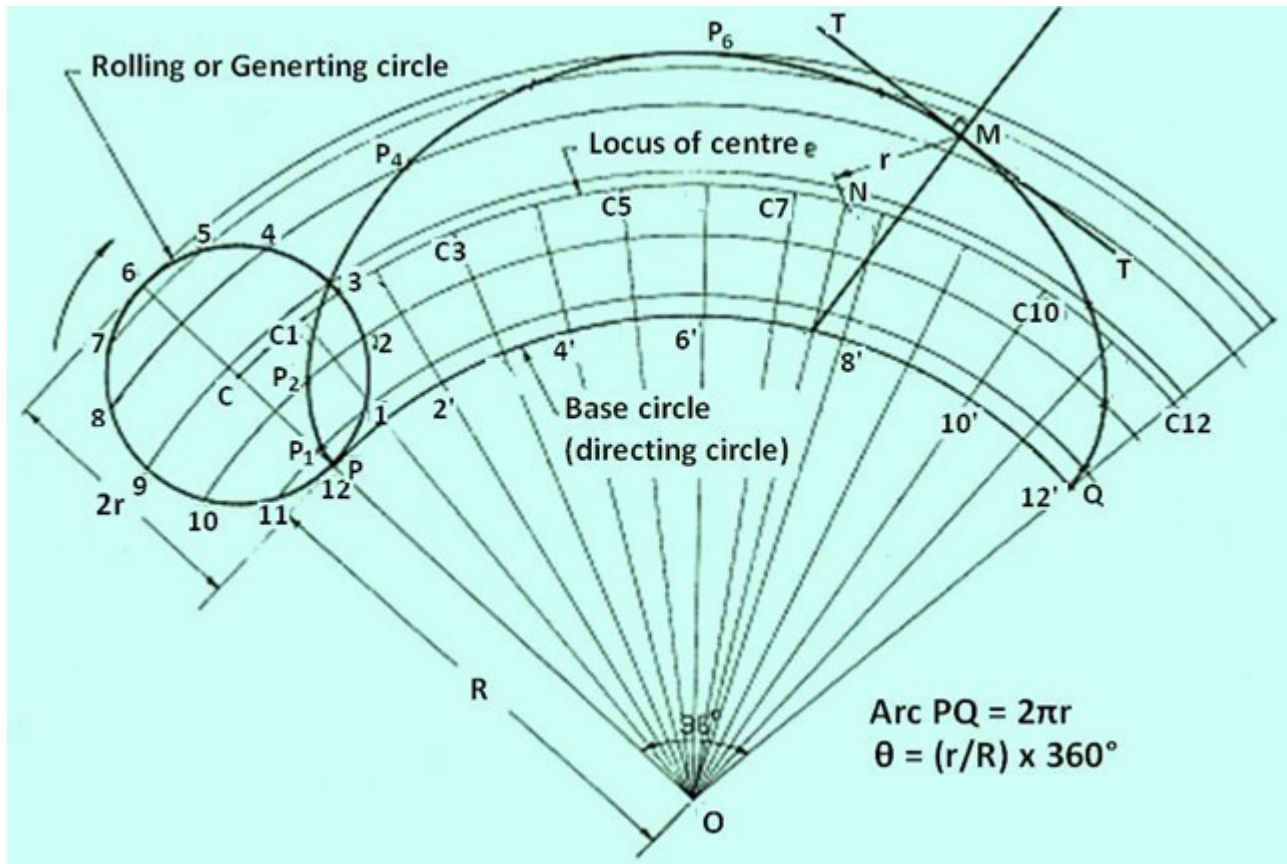

Figure 2. Illustrates the generation of an epicycloid.

With  $O$  as centre and radius  $OP$  (base circle radius), draw an arc  $PQ$ . The included angle  $\theta = (r/R) \times 360^\circ$ . With  $O$  as centre and  $OC$  as radius, draw an arc to represent locus of centre. Divide arc  $PQ$  in to 12 equal parts and name them as  $1', 2', \dots, 12'$ . Join  $O1', O2', \dots$  and produce them to cut the locus of centres at  $C1, C2, \dots, C12$ . Taking  $C1$  as centre, and radius equal to  $r$ , draw an arc cutting the arc through 1 at  $P1$ . Taking  $C2$  as centre and with the same radius, draw an arc cutting the arc through 2 at  $P2$ . Similarly obtain points  $P3, P3, \dots, P12$ . Draw a smooth curve passing through  $P1, P2, \dots, P12$ , which is the required epicycloid.

### Hypocycloid

Hypocycloid is the curve generated by a point on the circumference of a circle which rolls without slipping inside another circle.

The construction of a hypocycloid is illustrated in figure 3.

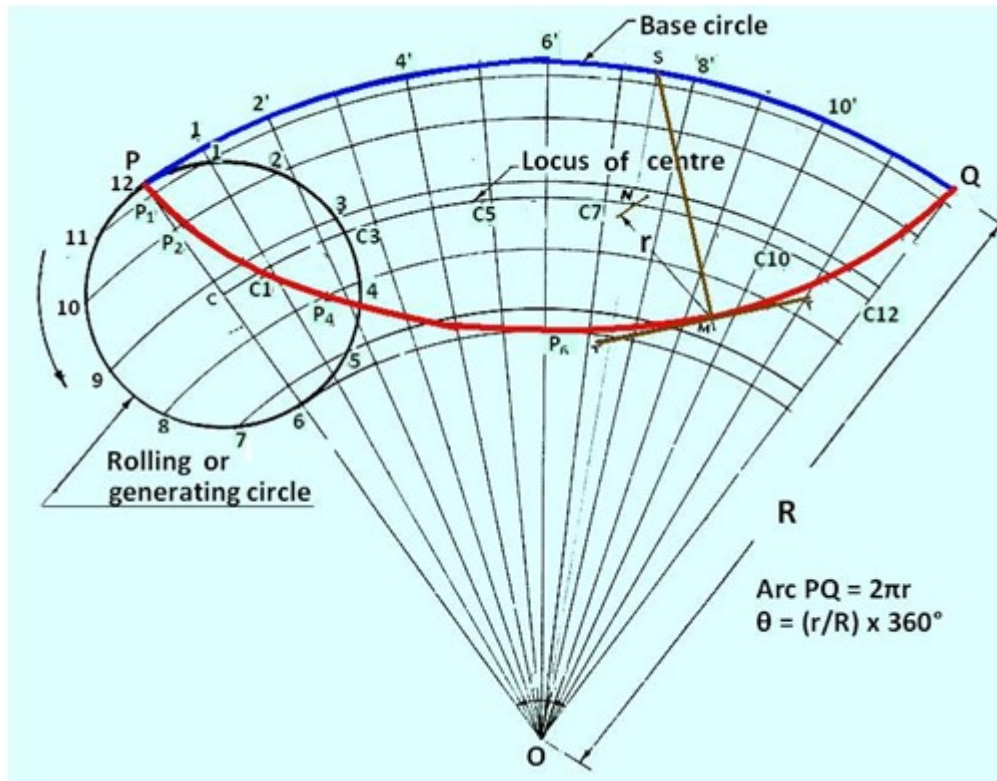

Figure 3 Construction of a hypocycloid.

With O as centre and radius OP (base circle radius), draw an arc PQ. The included angle  $\theta = (r/R) \times 360^\circ$ . With O as centre and OC as radius, draw an arc to represent locus of centre. Divide arc PQ in to 12 equal parts and name them as 1', 2', ..., 12'. Join O1', O2', ..., O12' so as to cut the locus of centres at C1, C2, ...C12. Taking C1 as centre, and radius equal to  $r$ , draw an arc cutting the arc through 1 at P1. Taking C2 as centre and with the same radius, draw an arc cutting the arc through 2 at P2. Similarly obtain points P3, P3, ..., P12. Draw a smooth curve passing through P1, P2..... , P12, which is the required hypocycloid.

### Involute

An *Involute* is a curve traced by the free end of a thread unwound from a circle or a polygon in such a way that the thread is always tight and tangential to the circle or side of the polygon. Figure 1 shows the involute of a circle.

### Construction of Involute of circle

- Draw the circle with c as center and CP as radius.
- Draw line  $PQ = 2\pi CP$ , tangent to the circle at P
- Divide the circle into 12 equal parts. Number them as 1, 2...
- Divide the line PQ into 12 equal parts and number as 1', 2'.....
- Draw tangents to the circle at 1, 2,3....
- Locate points P1, P2 such that 1-P1 = P1', 2-P2 = P2'.....
- Join P, P1, P2....
- The tangent to the circle at any point on it is always normal to the its involute.
- Join CN. Draw a semicircle with CN as diameter, cutting the circle at M. MN is the normal.

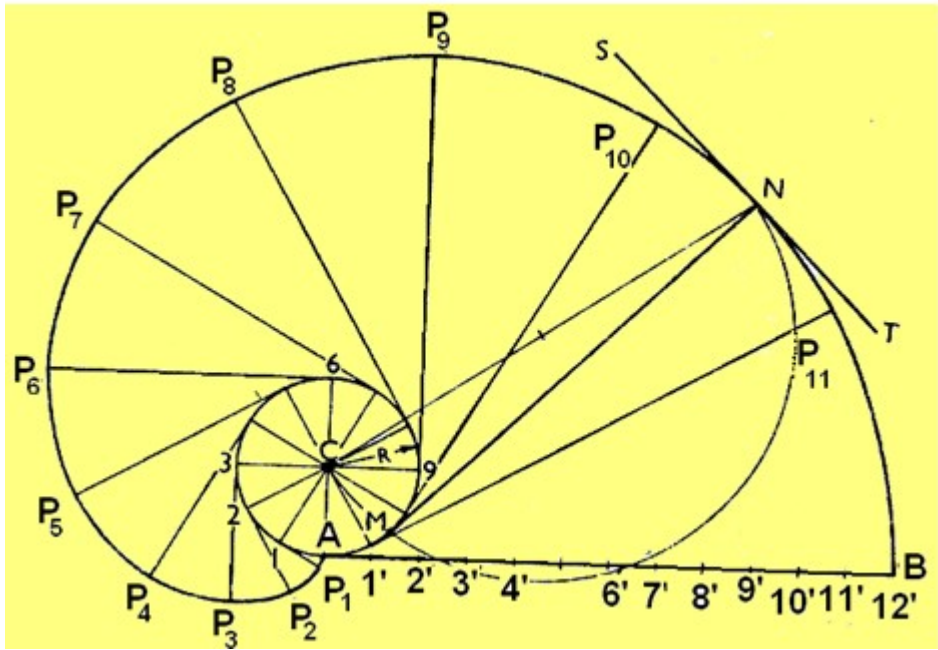

Figure 1. Construction of involute of a circle.

**Involute of Regular Polygon (pentagon)**

Figure 2 shows the construction of Involute of a regular pentagon. Draw the pentagon A-B-C-D-E. Extend line AE to P6 such that length E-P6 is equal to 5 times AE. Extend line BA, CB, DC, and ED. With A as centre and radius equal to AE draw an arc to intersect the line BA extended at P1. Next with B as centre and radius equal to A-1, draw an arc to intersect the line BA extended at P2. With C as centre and radius equal to A-2, draw an arc to intersect the line DC extended at P3. The procedure is repeated till point P5 is obtained. Draw a smooth curve passing through P1, P2, P3, ..., P5 to obtain the involute of the pentagon.

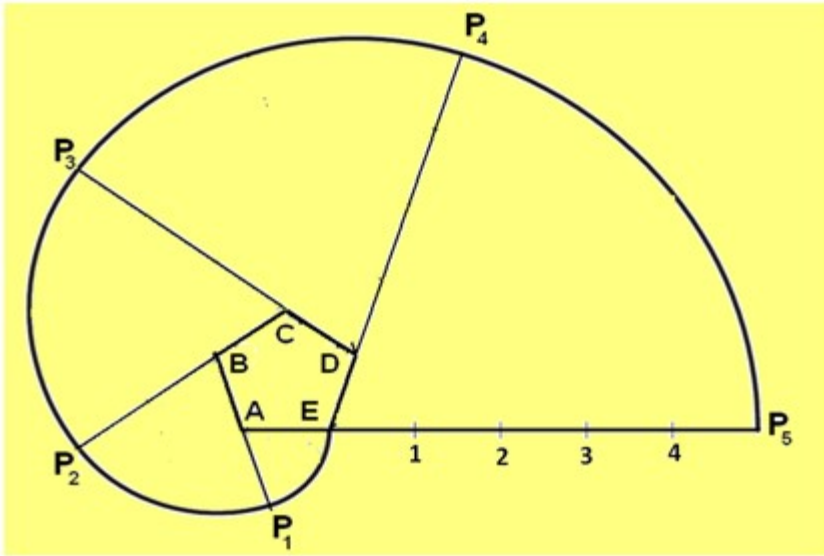

Figure 2. Involute of a pentagon.

## Lettering

Lettering is used for writing of titles, sub-titles, dimensions, scales and other details on a drawing. Typical lettering features used for engineering drawing is shown in figure 3. The following rules are to be followed in lettering. The letter sizes generally recommended for various items are shown in Table 1.

- Essential features of lettering – legibility, uniformity, ease, rapidity, and suitability for microfilming/photocopying/any other photographic processes
- No ornamental and embellishing style of letter
- Plain letters and numerals which are clearly distinguishable from each other in order to avoid any confusion even in case of slight mutilations

The Indian standard followed for lettering is BIS: 9609

- Single stroke lettering for use in engineering drawing – width of the stem of the letters and numerals will be uniformly thick equal to thickness of lines produced by the tip of the pencil.
- Single stroke does not mean – entire letter written without lifting the pencil/pen

Lettering types generally used for creating a drawing are

- Lettering A – Height of the capital letter is divided into 14 equal parts
- Lettering B – Height of the capital letter is divided into 10 equal parts

Table 2 and Table 3 indicates the specifications for Type A and Type B letters.

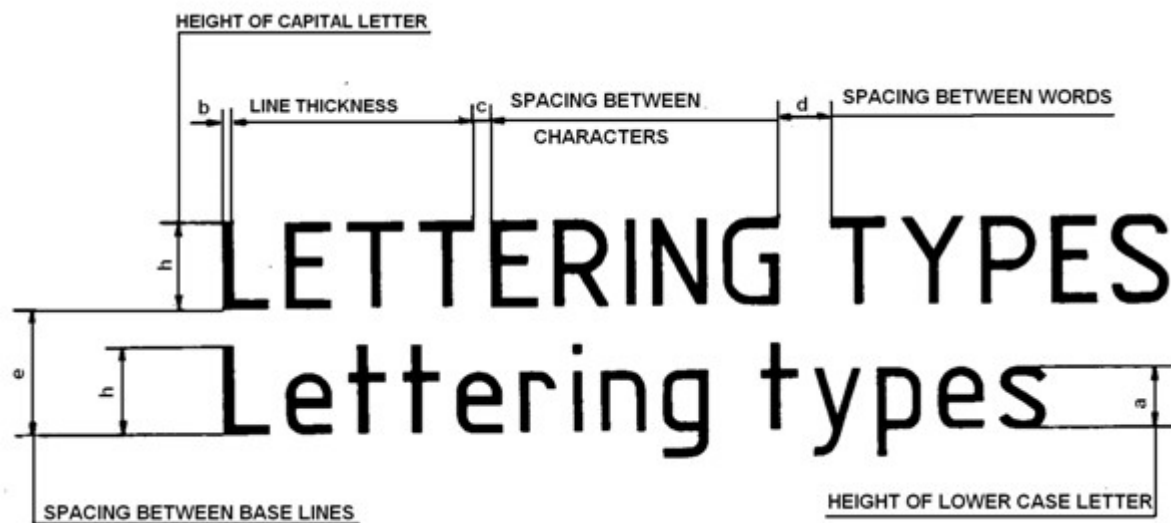

Figure 3. Typical lettering features.

### Heights of Letters and Numerals

1. Height of the capital letters is equal to the height of the numerals used in dimensioning
2. Height of letters and numerals – different for different purposes

Table 1 The letter sizes recommended for various items

Sr. No.	Item	Size (mm)
1	Name of the company	10, 14,20
2	Drawing numbers, letters denoting section planes	10, 14
3	Title of the Drawing	7, 10
4	Sub-titles and heading	5, 7
5	Dimensioning, Notes, Schedules, Material list	3.5, 7
6	Alteration entries and tolerances	3.5

Table 2. Specifications of A -Type Lettering

Specifications	Value	Size (mm)						
		2.5	3.5	5	7	10	14	20
Capital letter height	$h$	2.5	3.5	5	7	10	14	20
Lowercase letter height	$a = (5/7)h$	-	2.5	3.5	5	7	10	14
Thickness of lines	$b = (1/14)h$	0.18	0.25	0.35	0.5	0.7	1	1.4
Spacing between characters	$c = (1/7)h$	0.35	0.5	0.7	1	1.4	2	2.8
Min. spacing b/n words	$d = (3/7)h$	1.05	1.5	2.1	3	4.2	6	8.4
Min. spacing b/n baselines	$e = (10/7)h$	3.5	5	7	10	14	20	28

Table 3. Specifications of B -Type Lettering

Specifications	Value	Size (mm)						
		2.5	3.5	5	7	10	14	20
Capital letter height	$h$	2.5	3.5	5	7	10	14	20
Lowercase letter height	$a = (7/10)h$	-	2.5	3.5	5	7	10	14
Thickness of lines	$b = (1/10)h$	0.25	0.35	0.5	0.7	1	1.4	2
Spacing between characters	$c = (1/5)h$	0.5	0.7	1	1.4	2	2.8	4
Min. spacing b/n words	$d = (3/5)h$	1.5	2.1	3	4.2	6	8.4	12
Min. spacing b/n baselines	$e = (7/5)h$	3.5	5	7	10	14	20	28

How to begin your drawing?

To start with the preparation of a drawing the procedure mentioned below may be followed:

- Clean the drawing board and all the drawing instruments using duster.
- Fix the drawing sheet on the drawing board.
- Fix the mini-drafter in a convenient position.
- Draw border lines using HB pencil..
- Complete the title box using HB pencil .
- Plan spacing of drawings b/n two problems/views beforehand.
- Print the problem number on the left top and then commence the drawing work.

Keeping the drawing clean is a must

- Never sharpen pencils over drawing.
- Clean pencil point with a soft cloth after sharpening.
- Keep drawing instruments clean.
- Rest hands on drawing instruments as much as possible – to avoid smearing the graphite on the drawing.
- When darkening lines – try to work from the top of the drawing to the bottom, and from left to the right across the drawing.
- Use brush to remove eraser particles. Never use hands.
- Always use appropriate drawing pencils.

## EXCERCISE

### MULTIPLE CHOICE QUESTIONS:

1. Gothic lettering has all the alphabets and numerals of.....thickness.  
(a) non uniform (b) uniform (c) Both (a) and (b). (d) None of the above.
2. The lettering in which all the letters are formed by thick and thin elements is  
(a) free hand lettering. (b) gothic lettering. (c) roman lettering (d) None of the above.
3. In 7:4 ratio lettering, the height is taken as units.  
(a) 7 (b) 4 (c) 11 (d) 3
4. The ratio of height and width of a general letter is called  
(a) size of lettering.  
(b) ratio of lettering  
(c) Both (a) and (b)  
(d) None of the above
5. Instrumental single stroke lettering is obtained in .....  
(a) one stroke of pencil. (b) two (c) three (d) four
6. Good lettering has one of the following requirements:  
(a) It requires a thorough knowledge of the general shape of each alphabet  
(b) It requires a thorough knowledge of composition of alphabets.  
(c) It requires a thorough knowledge of general writing of alphabets in simple way.  
(d) All of the Above.

### Answers

1. (b)    2. (c)    3. (a)    4. (D)    5. (a)    6. (d)

## **B. SHORT ANSWER QUESTIONS:**

1. Define lettering.
2. What are the requirements of good lettering?
3. Classify lettering.
4. Define gothic lettering. Name its types.
5. Define free hand lettering
6. Define Roman lettering.
7. What is normal lettering?
8. What is condensed lettering?
9. What is extended lettering?
10. What do you understand by spacing in lettering?
11. Differentiate between single stroke and double stroke lettering.
12. Differentiate between free hand lettering and instrumental lettering.
13. What do you understand by size of lettering and ratio of lettering?
14. Draw the letter 'A' in single stroke vertical and inclined gothic lettering taking height 35 mm and ratio 7: 4.
15. Draw the following free hand take size equal to 5mm.  
'TECHNICAL EDUCATION'

### **Scales**

There is a wide variation in sizes for engineering objects. Some are very large (eg. Aero planes, rockets, etc) Some are vey small ( wrist watch, MEMs components)

There is a need to reduce or enlarge while drawing the objects on paper. Some objects can be drawn to their actual size. The proportion by which the drawing of aan object is enlarged or reduced is called the scale of the drawing.

### **Definition**

A scale is defined as the ratio of the linear dimensions of the object as represented in a drawing to the actual dimensions of the same.

- Drawings drawn with the same size as the objects are called full sized drawing.
- It is not convenient, always, to draw drawings of the object to its actual size. e.g. Buildings,
- Heavy machines, Bridges, Watches, Electronic devices etc.
- Hence scales are used to prepare drawing at
  - Full size
  - Reduced size
  - Enlarged size

**BIS Recommended Scales are shown in table 1.**

Table 1. The common scales recommended.

<b>Reducing scales</b> 1:Y (Y>1)	1:2	1:5	1:10
	1:20	1:50	1:100
	1:200	1:500	1:1000
	1:2000	1:5000	1:10000
<b>Enlarging scales</b> X:1 (X>1)	50:1	20:1	10:1
	5:1	2:1	
<b>Full size scales</b>			1:1

*Intermediate scales can be used in exceptional cases where recommended scales can not be applied for functional reasons.*

### Types of Scale :-

**Engineers Scale :** The relation between the dimension on the drawing and the actual dimension of the object is mentioned numerically (like 10 mm = 15 m).

**Graphical Scale:** Scale is drawn on the drawing itself. This takes care of the shrinkage of the engineer's scale when the drawing becomes old

### Types of Graphical Scale :-

- Plain Scale
- Diagonal Scale
- Vernier Scale
- Comparative scale
- Scale of chords

### Representative fraction (R.F.) :-

$$\text{R.F.} = \frac{\text{Length of an object on the drawing}}{\text{Actual Length of the object}}$$

When a 1 cm long line in a drawing represents 1 meter length of the object

$$R.F = \frac{1\text{cm}}{1\text{m}} = \frac{1\text{cm}}{1 \times 100\text{cm}} = \frac{1}{100}$$

Length of scale = RF x Maximum distance to be represented

### Plain scale :-

- A plain scale is used to indicate the distance in a unit and its next subdivision.

- A plain scale consists of a line divided into suitable number of equal units. The first unit is subdivided into smaller parts.
- The zero should be placed at the end of the 1st main unit.
- From the zero mark, the units should be numbered to the right and the sub-divisions to the left.
- The units and the subdivisions should be labeled clearly.
- The R.F. should be mentioned below the scale.

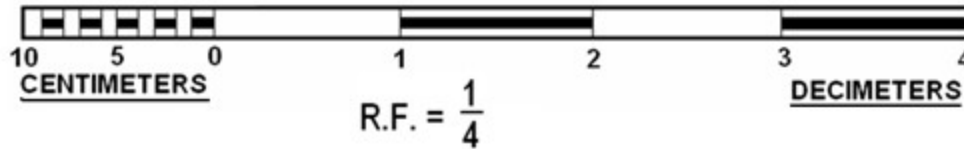

Construct a plain scale of RF = 1:4, to show centimeters and long enough to measure up to 5 decimeters.

- R.F. =  $\frac{1}{4}$
- Length of the scale = R.F.  $\times$  max. length =  $\frac{1}{4} \times 5 \text{ dm} = 12.5 \text{ cm}$ .
- Draw a line 12.5 cm long and divide it in to 5 equal divisions, each representing 1 dm.
- Mark 0 at the end of the first division and 1, 2, 3 and 4 at the end of each subsequent division to its right.
- Divide the first division into 10 equal sub-divisions, each representing 1 cm.
- Mark cm to the left of 0 as shown.
- Draw the scale as a rectangle of small width (about 3 mm) instead of only a line.
- Draw the division lines showing decimeters throughout the width of the scale.
- Draw thick and dark horizontal lines in the middle of all alternate divisions and sub-divisions.
- Below the scale, print DECIMETERS on the right hand side, CENTIMETERS on the left hand side, and R.F. in the middle.

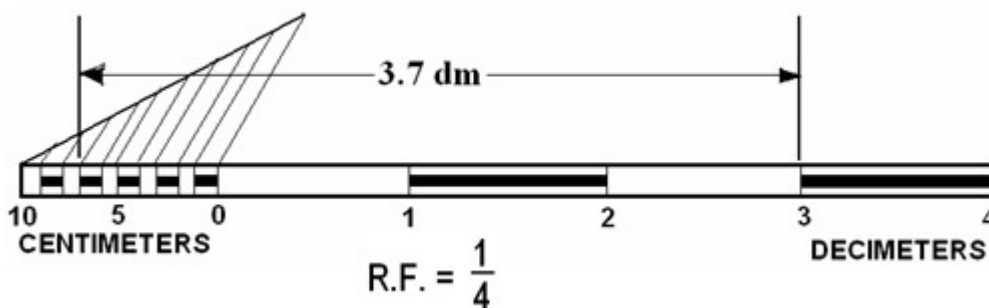

### Diagonal Scale :-

- Through Diagonal scale, measurements can be up to second decimal places (e.g. 4.35).
- Are used to measure distances in a unit and its immediate two subdivisions; e.g. *dm, cm & mm*, or *yard, foot & inch*.
- Diagonal scale can measure more accurately than the plain scale.

## Diagonal scale.....Concept

- At end B of line AB, draw a perpendicular.
- Step-off ten equal divisions of any length along the perpendicular starting from B and ending at C.
- Number the division points 9,8,7,.....1.
- Join A with C.
- Through the points 1, 2, 3, etc., draw lines parallel to AB and cutting AC at 1', 2', 3', etc.
- Since the triangles are similar; 1'1 = 0.1 AB, 2'2 = 0.2AB, .... 9'9 = 0.9AB.
- Gives divisions of a given short line AB in multiples of 1/10 its length, e.g. 0.1AB, 0.2AB, 0.3AB, etc.

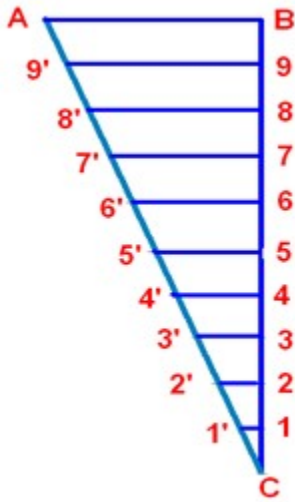

Construct a Diagonal scale of RF = 3:200 showing meters, decimeters and centimeters. The scale should measure up to 6 meters. Show a distance of 4.56 meters

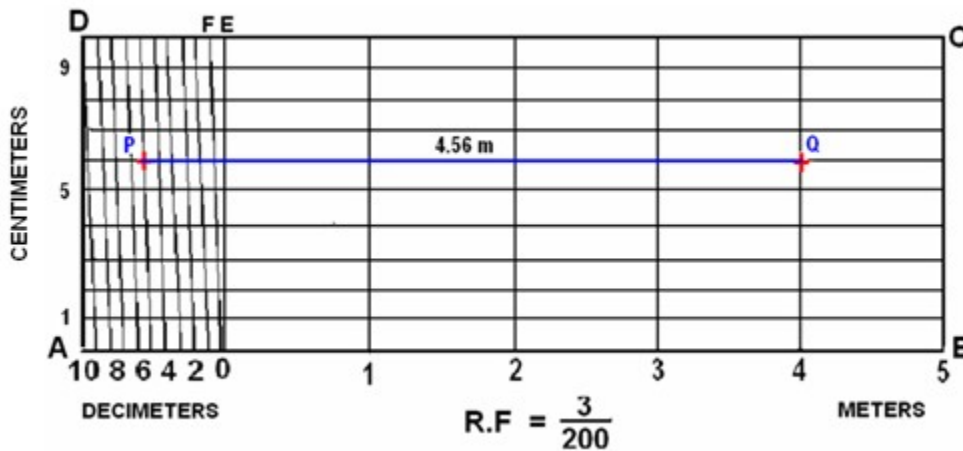

- Length of the scale =  $(3/200) \times 6 \text{ m} = 9 \text{ cm}$
- Draw a line AB = 9 cm . Divide it in to 6 equal parts.
- Divide the first part A0 into 10 equal divisions.
- At A draw a perpendicular and step-off along it 10 equal divisions, ending at D.

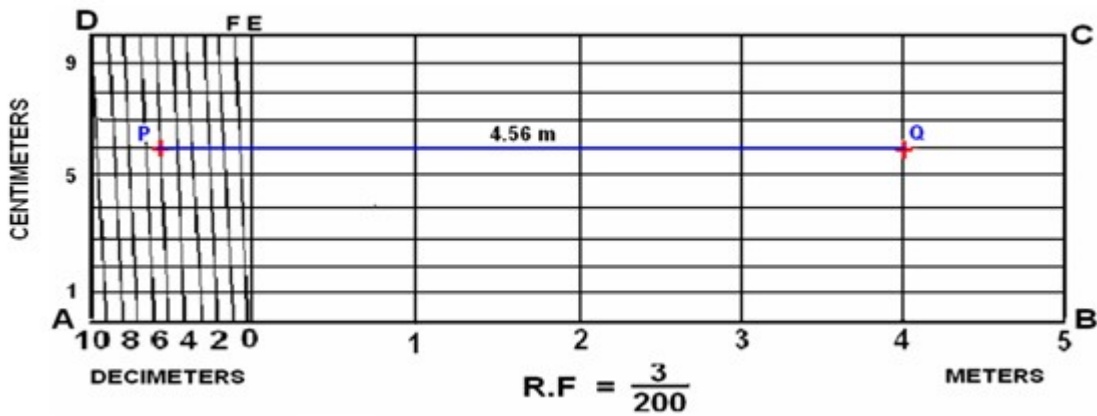

Complete the rectangle ABCD.

- Draw perpendiculars at meter-divisions i.e. 1, 2, 3, and 4.
- Draw horizontal lines through the division points on AD. Join D with the end of the first division along A0 (i.e. 9).
- Through the remaining points i.e. 8, 7, 6, ... draw lines // to D9.
- PQ = 4.56 meters

## EXCERCISE

### MULTIPLE CHOICE QUESTIONS

- Diagonal scale is used to represent
  - three units.
  - one unit and its fraction upto two decimal places.
  - two units.
  - Both (a) and (b).
- For drawing of small instruments like watches etc..... scale is used.
  - reducing
  - full size
  - increasing
  - None of the above.
- When measurements are required in their units, ..... scale is used.
  - diagonal
  - comparative
  - plain
  - None of the above
- R.F. is....
  - Actual distance of the object Distance of the object on drawing (in same units)
  - Distance of the object on drawing Corresponding actual distance of the object (in same units)
  - Both (a) and (b).
  - None of (a) and (b).
- Full size scale is indicated as
  - 1:1
  - 10:10
  - 100:100
  - All of the above
- Plain scale represents
  - two units.
  - one unit and its sub-division
  - Bath (a) and (b).
  - None of (a) and (b).
- $1/25^{\text{th}}$  scale is indicated as
  - 25:1
  - 1:25
  - 1:5
  - 5:1.
- Scale is used for
  - drawing and object according to drawing data available.
  - drawing a larger size of the object.
  - drawing a smaller size of the object.
  - All of the above.

9. In increasing scale,  
(a) the actual measurements of the object are increased.  
(b) the actual measurements of the object are reduced.  
(c) Both (a) and (b).  
(d) None of (a) and (b).

#### ANSWERS

1. (d)            2. (c)            3. (c)            4. (b)            5. (d)  
6. (c)            7. (b)            8. (d)            9. (a)

#### B. SHORT ANSWER QUESTIONS:

1. Define scale.
2. What is increasing scale?
3. Define full scale.
4. What do you mean by reducing scale?
5. Name different types of scales.
6. Define representative fraction.
7. Define plain scale.
8. Define diagonal scale.
9. Give uses of scales.

#### **Dimensioning**

The size and other details of the object essential for its construction and function, using lines, numerals, symbols, notes, etc are required to be indicated in a drawing by proper dimensioning. These dimensions indicated should be those that are essential for the production, inspection and functioning of the object and should be mistaken as those that are required to make the drawing of an object. The dimensions are written either above the dimension lines or inserted at the middle by breaking the dimension lines.

Normally two types of dimensioning system exist. i.e. Aligned system and the unidirectional system. These are shown in figure 1.

In the aligned system the dimensions are placed perpendicular to the dimension line in such a way that it may be read from bottom edge or right hand edge of the drawing sheet. The horizontal and inclined dimension can be read from the bottom where as all the vertical dimensions can be read from the right hand side of the drawing sheet. In the unidirectional system, the dimensions are so oriented such that they can be read from the bottom of the drawing.

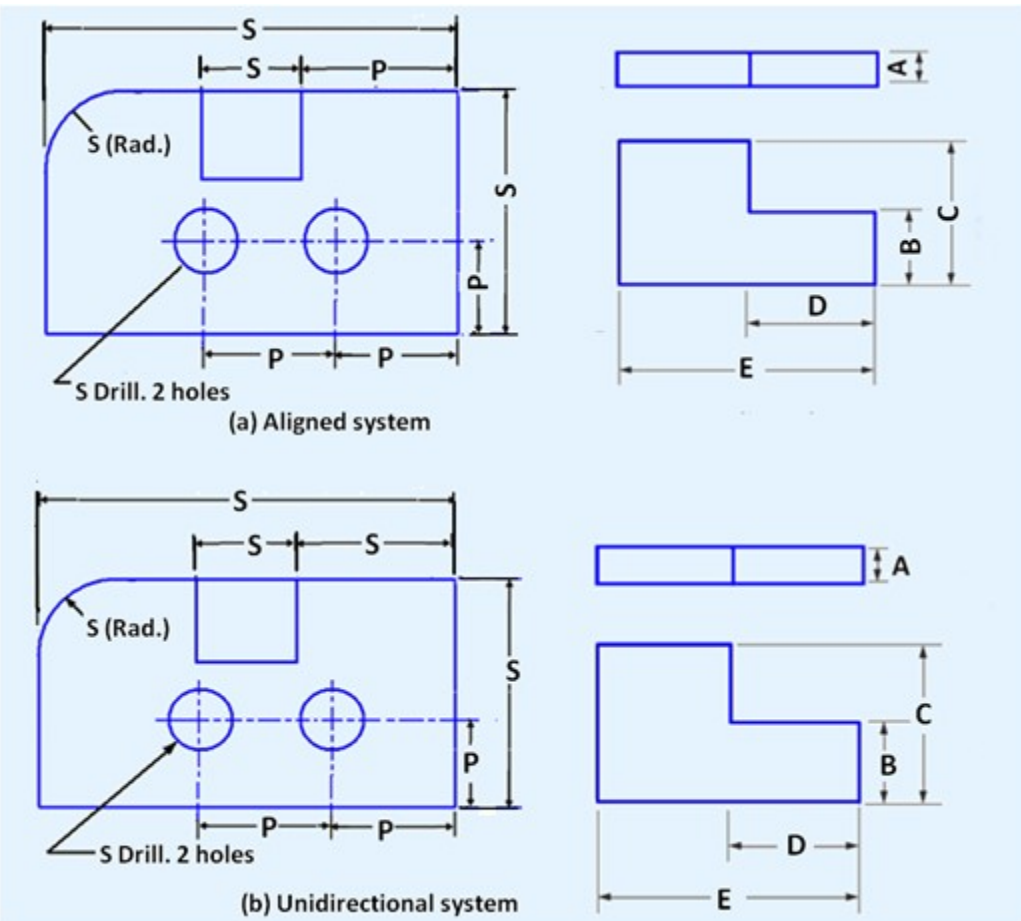

Figure 1. The aligned system and unidirectional system of dimensioning.

**Rules to be followed for dimensioning. Refer figure 2.**

- Each feature is dimensioned and positioned only once.
- Each feature is dimensioned and positioned where its shape shows.
- Size dimensions – give the size of the component.
- Every solid has three dimensions, each of the geometric shapes making up the object must have its height, width, and depth indicated in the dimensioning.

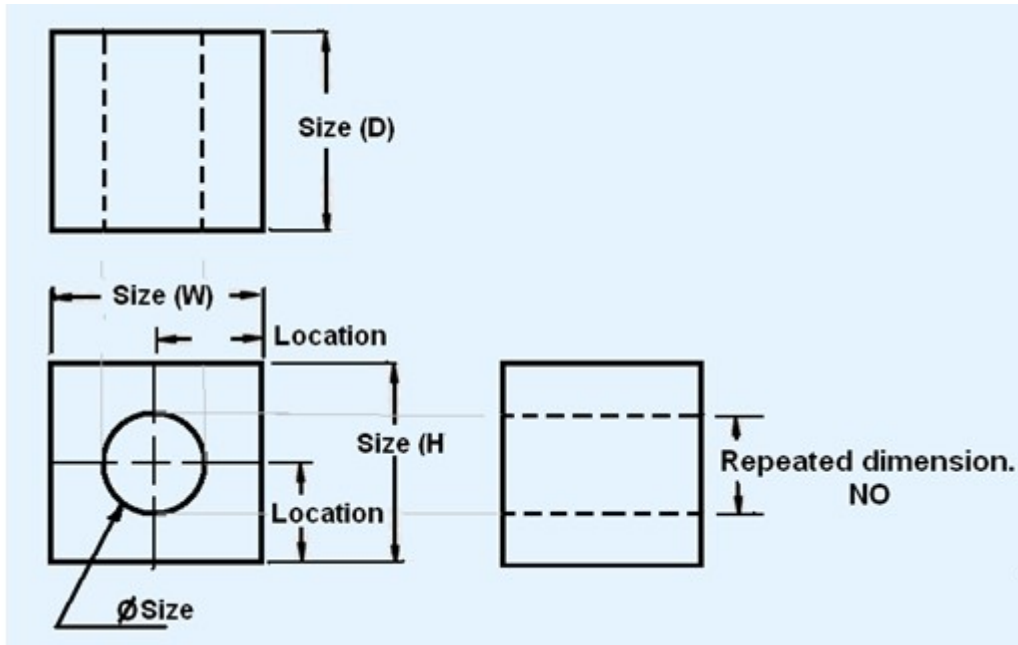

Figure 2. typical dimension lines

**Dimensioning consists of the following:**

- A thin, solid line that shows the extent and direction of a dimension. Dimension lines are broken for insertion of the dimension numbers
- Should be placed at least 10 mm away from the outline and all
- other parallel dimensions should be at least 6 mm apart, or more, if space permits

The important elements of dimensioning consists of extension lines, leader line, arrows and dimensions.

**Extension line** – a thin, solid line perpendicular to a dimension line, indicating which feature is associated with the dimension. There should be a visible gap of 1.5 mm between the feature’s corners and the end of the extension line. Figure 3 shows extension lines.

**Leader line**

A thin, solid line used to indicate the feature with which a dimension, note, or symbol is associated. Generally this is a straight line drawn at an angle that is neither horizontal nor vertical. Leader line is terminated with an arrow touching the part or detail. On the end opposite the arrow, the leader line will have a short, horizontal shoulder. Text is extended from this shoulder such that the text height is centered with the shoulder line

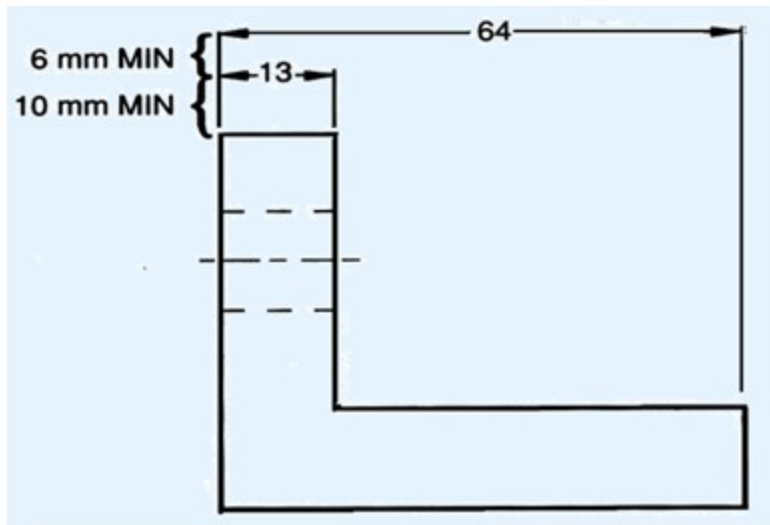

Figure 3. showing extension lines

- Arrows – 3 mm wide and should be 1/3rd as wide as they are long - symbols placed at the end of dimension lines to show the limits of the dimension. Arrows are uniform in size and style, regardless of the size of the drawing. Various types of arrows used for dimensioning is shown in figure 4.

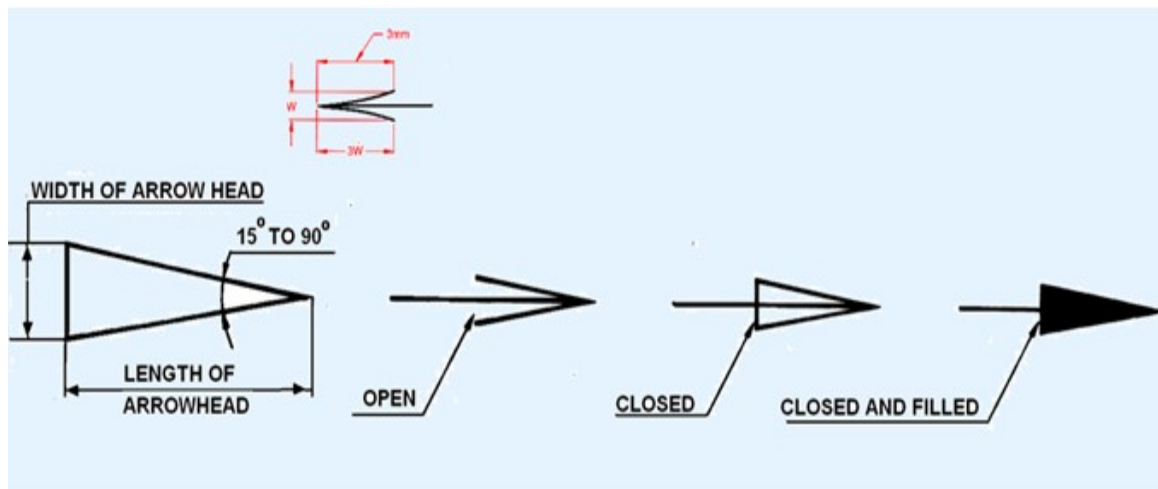

Figure 4. Various types of arrows used for dimensioning

The specification of dimension lines are shown in figure 5.

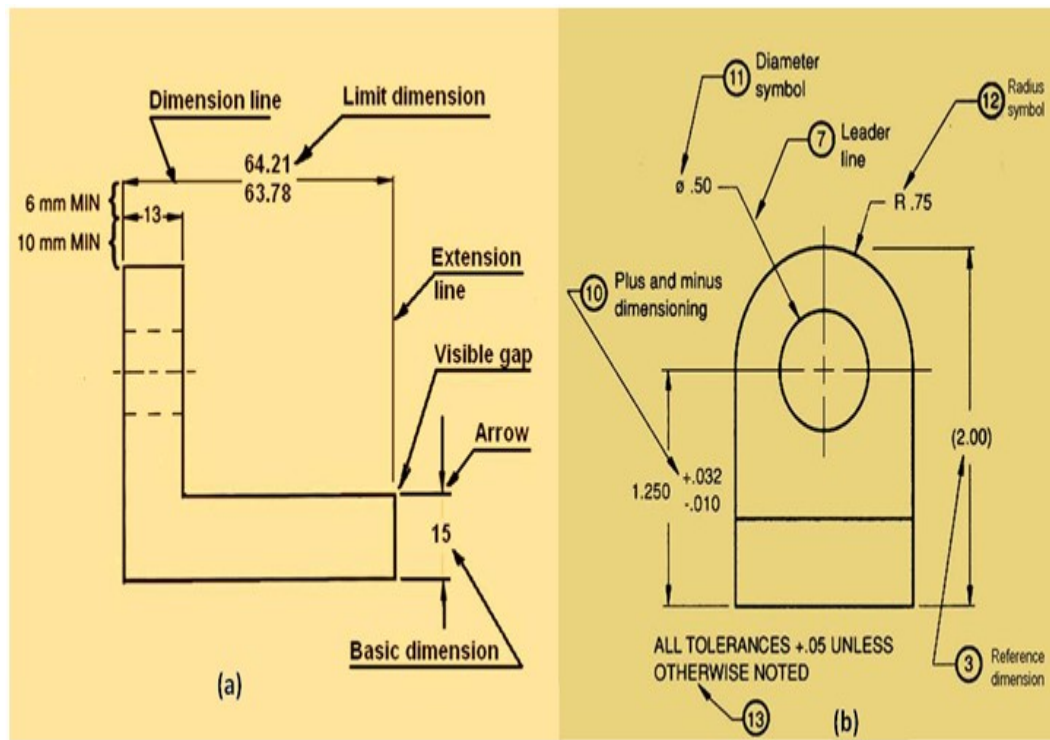

Figure 5 showing the specification of dimension lines.

**Dimensioning of angles:** The normal convention for dimensioning of angles are illustrated in figure 6.

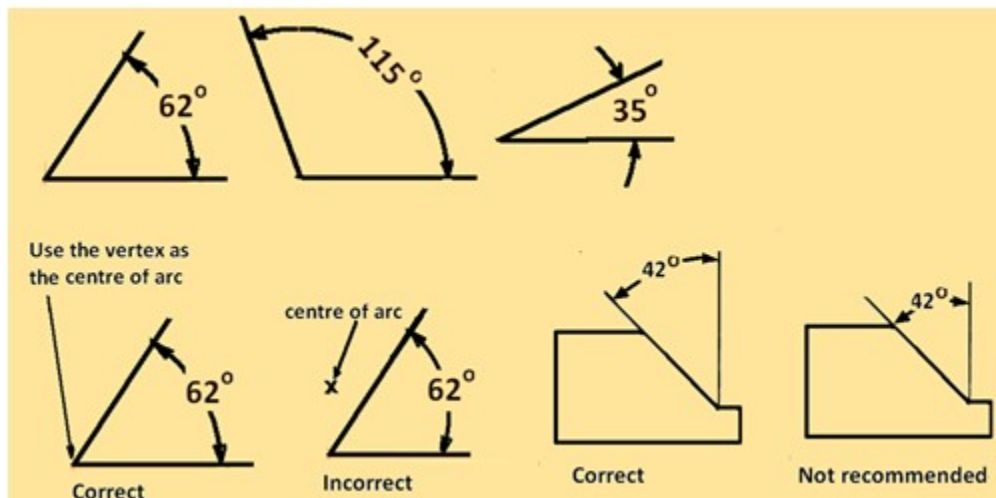
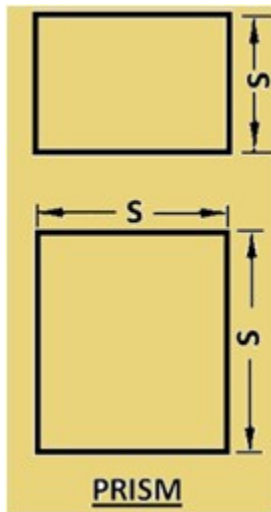

Figure 6 conventions used for dimensioning angles.

**Few examples during dimensioning of solids are shown below:**

- Prism – This is the most common shape and requires three dimensions. Two dimensions shown on the principal view and the third dimension on the other view.



- Cylinder – Cylinder is the second most common shape. It requires two dimensions: diameter and length, both shown preferably on the rectangular view.

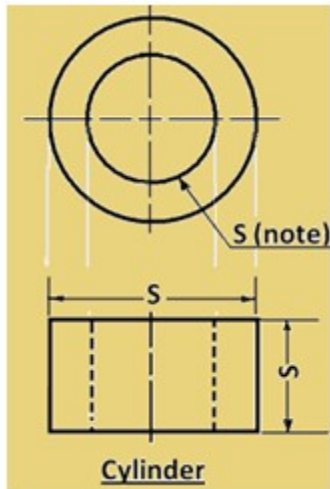

- Cone – requires two dimensions – diameter of the base and altitude on the same view and length. Both shown on the rectangular view is preferred.

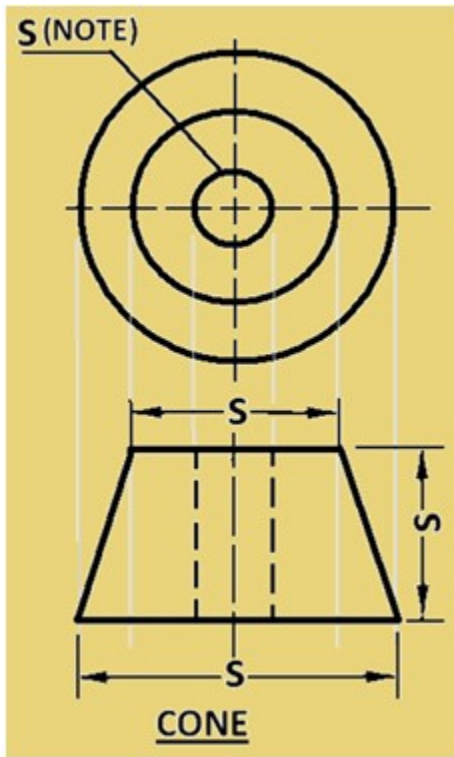

- 1
- Right pyramids – requires three dimensions – dimensions of the base and altitude.

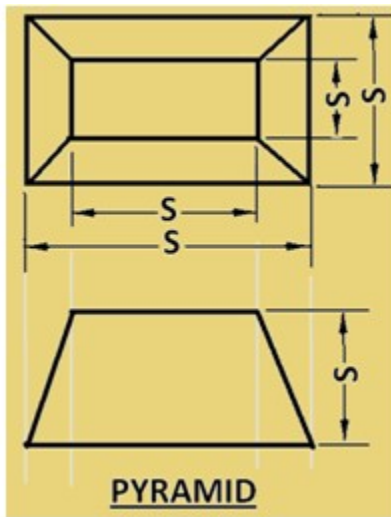

- Spheres – requires only one dimension. i.e. diameter. However in case of extra features, those dimensions are required to be provided.

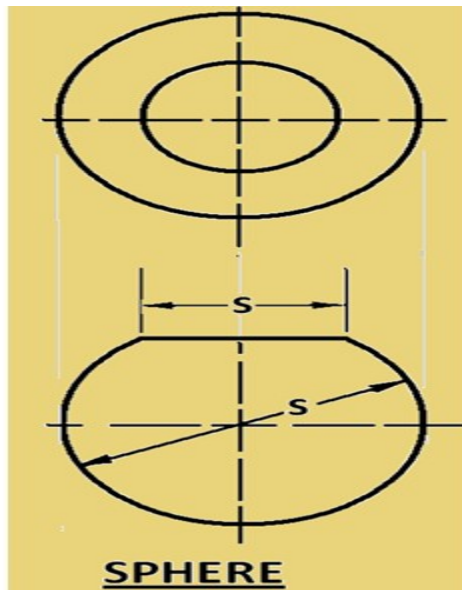

## RULES OF DIMENSIONING

1. Between any two extension lines, there must be one and only one dimension line bearing one dimension.
2. As far as possible, all the dimensions should be placed outside the views. Inside dimensions are preferred only if they are clearer and more easily readable.
3. All the dimensions on a drawing must be shown using either Aligned System or Unidirectional System. In no case should, the two systems be mixed on the same drawing.
4. The same unit of length should be used for all the dimensions on a drawing. The unit should not be written after each dimension, but a note mentioning the unit should be placed below the drawing.
5. Dimension lines should not cross each other. Dimension lines should also not cross any other lines of the object.
6. All dimensions must be given.
7. Each dimension should be given only once. No dimension should be redundant.
8. Do not use an outline or a centre line as a dimension line. A centre line may be extended to serve as an extension line.
9. Avoid dimensioning hidden lines.
10. For dimensions in series, adopt any one of the following ways.
  - i. Chain dimensioning (Continuous dimensioning) All the dimensions are aligned in such a way that an arrowhead of one dimension touches tip-to-tip the arrowhead of the adjacent dimension. The overall dimension is placed outside the other smaller dimensions.
  - ii. Parallel dimensioning (Progressive dimensioning) All the dimensions are shown from a common reference line. Obviously, all these dimensions share a common extension line. This method is adopted when dimensions have to be established from a particular datum surface
  - iii. Combined dimensioning. When both the methods, i.e., chain dimensioning and parallel dimensioning are used on the same drawing, the method of dimensioning is called combined dimensioning.

## EXCERCISE

### MULTIPLE CHOICE QUESTIONS:

1. The correct way of dimensioning the chamfer is

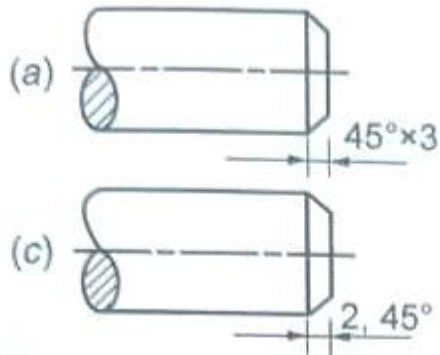

(d) None of the above.

2. All dimensions are shown from a common base line in

- (a) chain dimensioning                      (b) parallel dimensioning  
(c) progressive dimensioning              (d) unidirectional dimensioning.

3. Length of an arrow head is ..... times the thickness of arrow head.

- (a) two      (b) three      (c) five      (d) None of the above

### ANSWERS

1. (b)              2. (c)              3. (b)

### B. SHORT ANSWER QUESTIONS:

1. Define dimensioning
2. Name types of dimensioning.
3. Name systems of placing dimensions.
4. Define uni-directional system of dimensioning.
5. Define aligned system of dimensioning.
6. Draw a figure which shows uni-directional system of dimensioning.
7. Draw a figure which shows aligned system of dimensioning.
8. What should be the unit of dimensioning?
9. What should be the size proportion of arrow head.
10. Show the dimensioning of angle
11. Show the dimensioning of arc and radius.

## Unit- 2 - Theory of Projections

### Projection theory

In engineering, 3-dimensional objects and structures are represented graphically on a 2-dimensional media. The act of obtaining the image of an object is termed “projection”. The image obtained by projection is known as a “view”. A simple projection system is shown in figure 1.

All projection theory are based on two variables:

- Line of sight
- Plane of projection.

### Plane of Projection

A plane of projection (i.e, an image or picture plane) is an imaginary flat plane upon which the image created by the line of sight is projected. The image is produced by connecting the points where the lines of sight pierce the projection plane. In effect, 3-D object is transformed into a 2-D representation, also called projections. The paper or computer screen on which a drawing is created is a plane of projection.

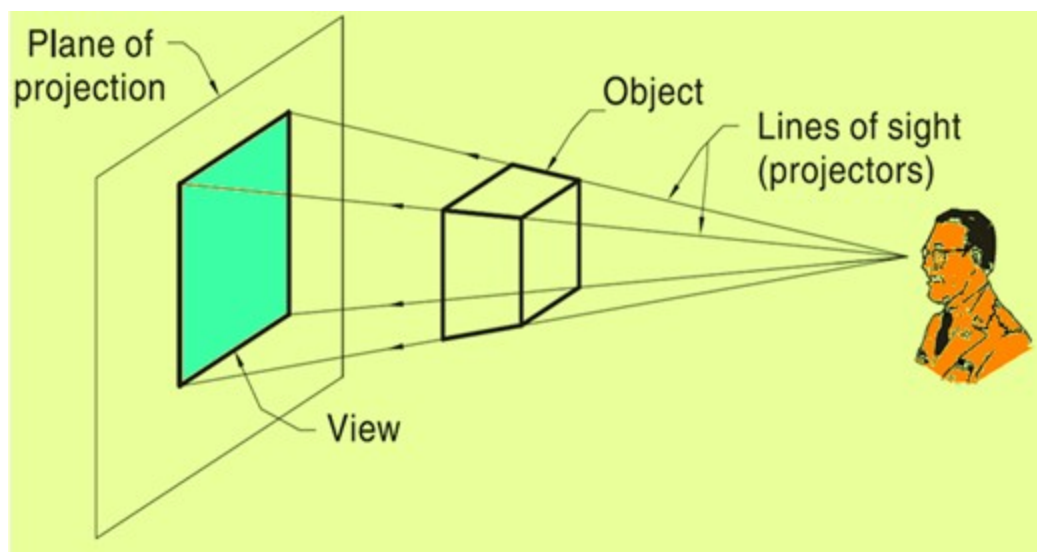

Figure 1 : A simple Projection system

### Projection Methods

Projection methods are very important techniques in engineering drawing.

Two projection methods used are:

- Perspective and
- Parallel

Figure 2 shows a photograph of a series of building and this view represents a perspective projection on to the camera. The observer is assumed to be stationed at finite distance from the object. The height of the buildings appears to be reducing as we move away from the observer. In perspective projection, all lines of sight start at a single point and is schematically shown in figure 3. .



Figure 2. Photographic image of a series of buildings.

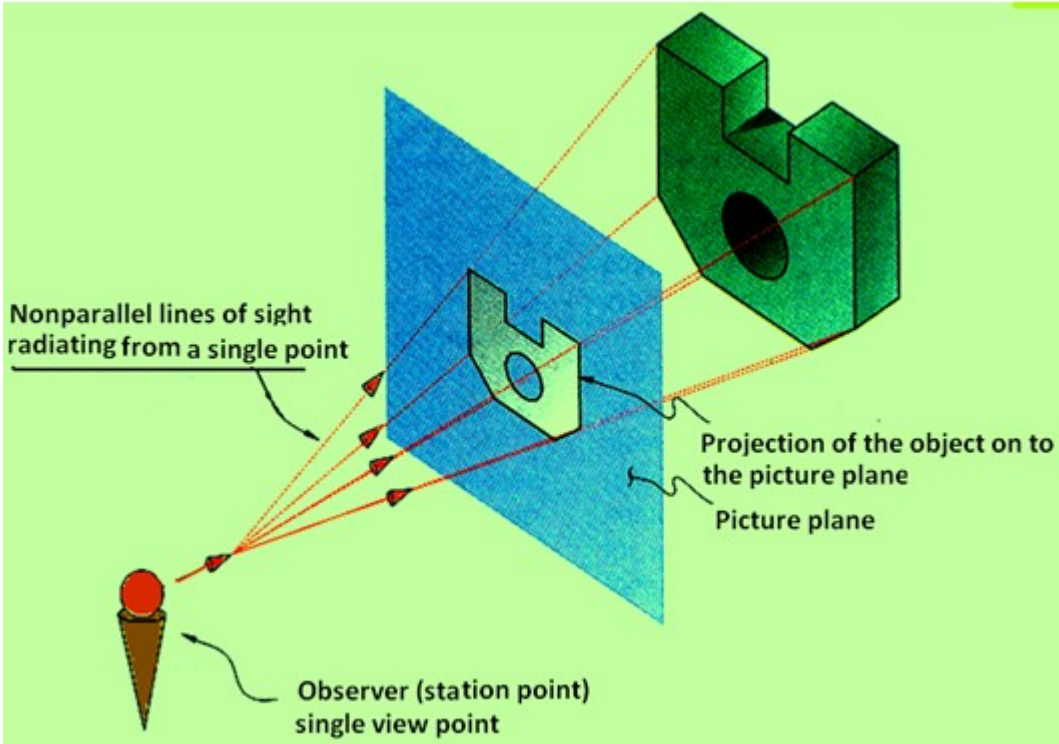

Figure 3. A schematic representation of a Perspective projection

In parallel projection, all lines of sight are parallel and is schematically represented in figure. 4. The observer is assumed to be stationed at infinite distance from the object.

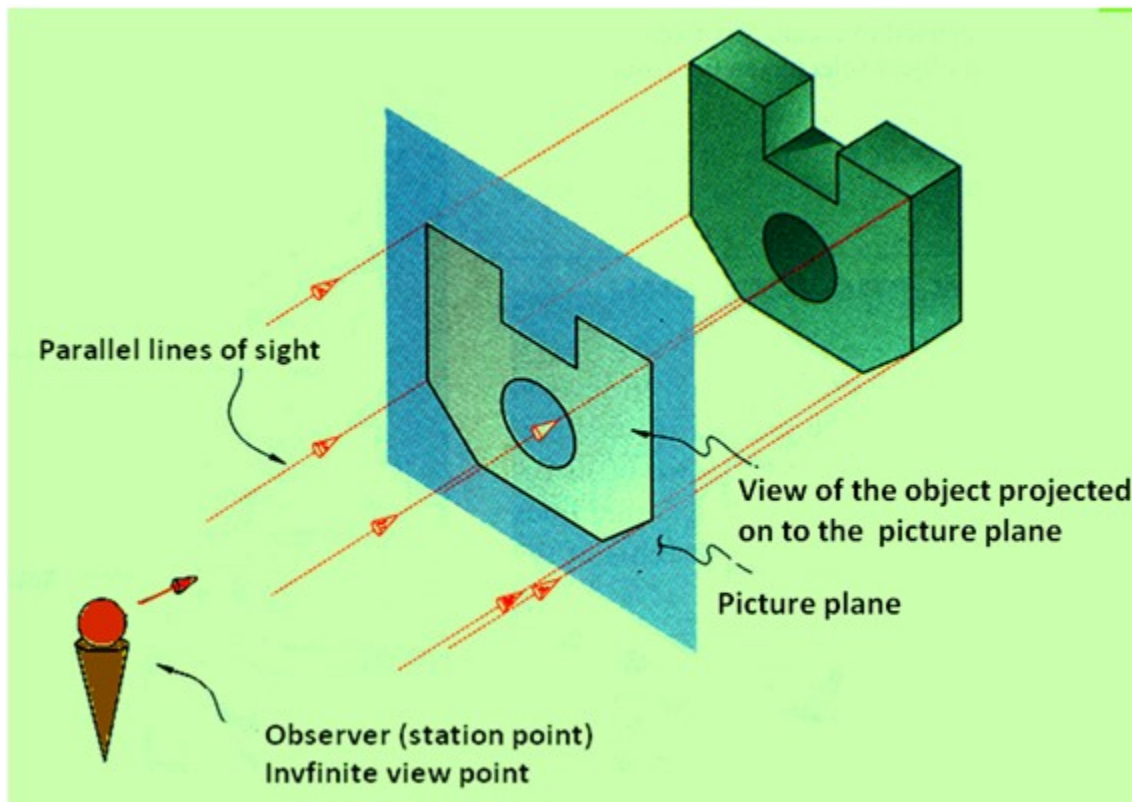

Figure 4. A schematic representation of a Parallel projection

## Parallel vs Perspective Projection

### Parallel projection

√ Distance from the observer to the object is infinite projection lines are parallel – object is positioned at infinity.

√ Less realistic but easier to draw.

### Perspective projection

- Distance from the observer to the object is finite and the object is viewed from a single point – projectors are not parallel.
- Perspective projections mimic what the human eyes see, however, they are difficult to draw.

### Orthographic Projection

Orthographic projection is a parallel projection technique in which the plane of projection is perpendicular to the parallel line of sight. Orthographic projection technique can produce either pictorial drawings that show all three dimensions of an object in one view or multi-views that show only two dimensions of an object in a single view. These views are shown in figure 5.

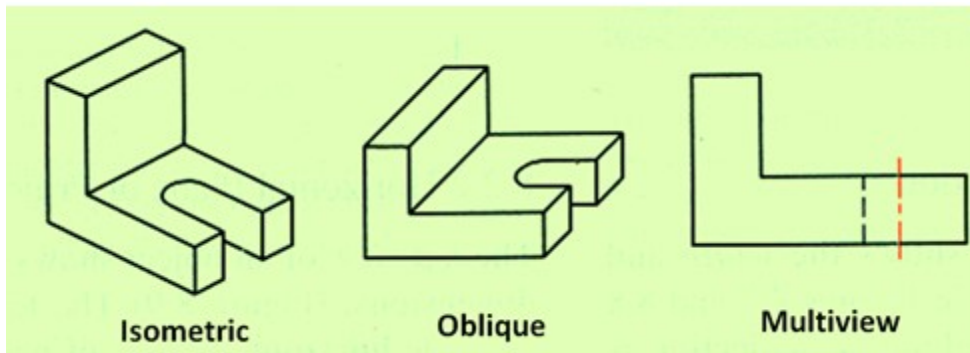

Figure 5. Orthographic projections of a solid showing isometric, oblique and multi-view drawings.

### Transparent viewing box

Assume that the object is placed in a transparent box, the faces of which are orthogonal to each other, as shown in figure 6. Here we view the object faces normal to the three planes of the transparent box.

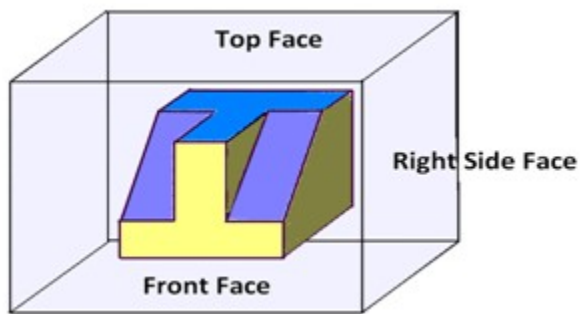

Figure 6. The object placed inside a transparent box.

When the viewing planes are parallel to these principal planes, we obtain the Orthographic views. The picture we obtain when the line of sight is projected on to each plane is called as the respective view of the object. The image obtained on the projection planes, i.e., on the top face, Front Face, and Right side face are respectively the Top View, Front view and Right side view of the object and is shown in figure 7.

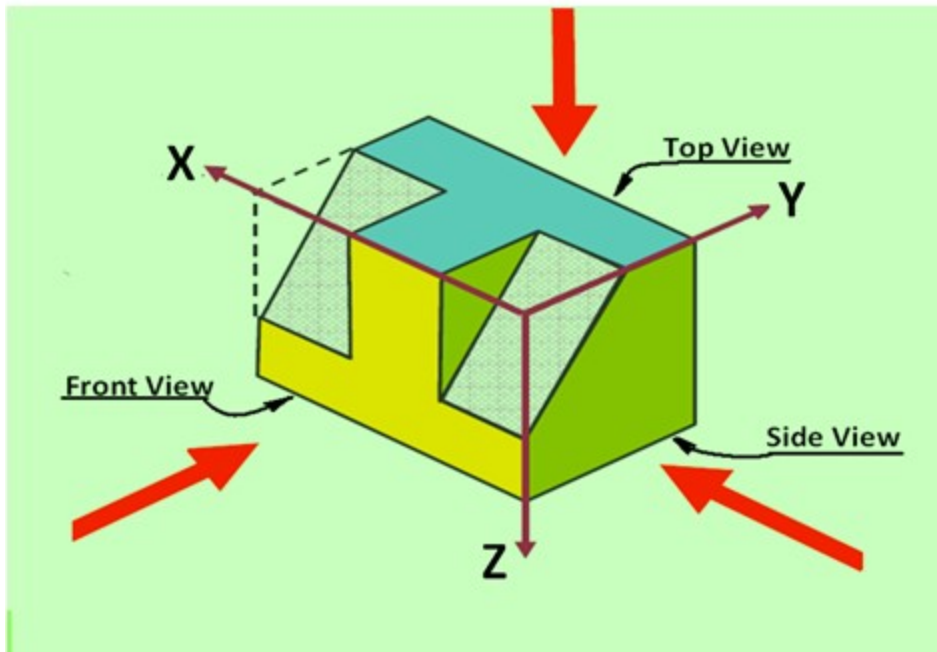

Figure 7 showing the Front view, Top View and Side view of an object

### Multi-view Projection

In an orthographic projection, the object is oriented in such a way that only two of its dimensions are shown. The dimensions obtained are the true dimensions of the object .

### Frontal plane of projection

Frontal plane of projection is the plane onto which the Front View (FV) of the multi-view drawing is projected. Figure 8 illustrates the method of obtaining the Front view of an object. Front view of an object shows the width and height dimensions.

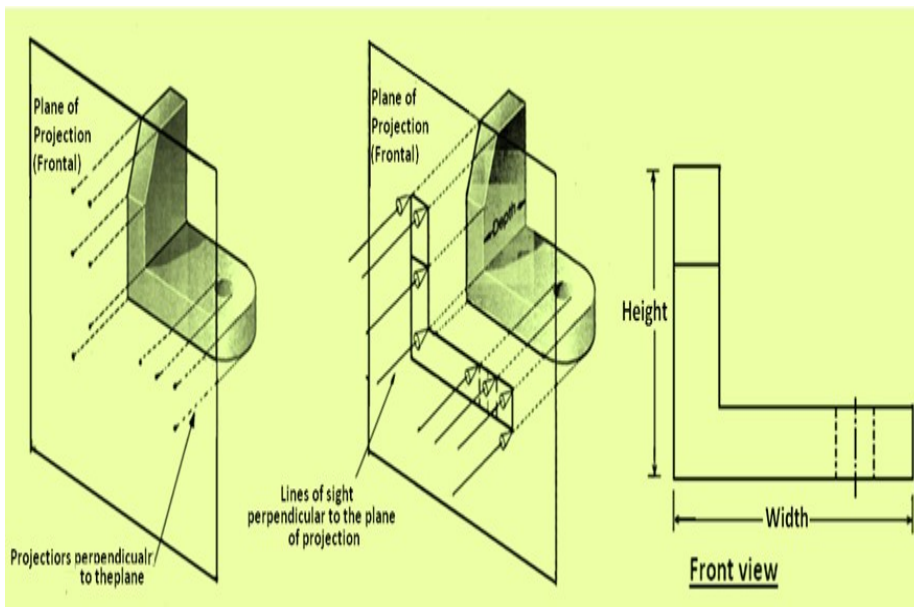

Figure 8 illustrates the method of obtaining the Front view of an object.

### Horizontal plane of projection

Horizontal plane of projection is the plane onto which the Top View of the multi-view drawing is projected and is shown in Figure 9. The Top view of an object shows the width and depth dimensions of the object.

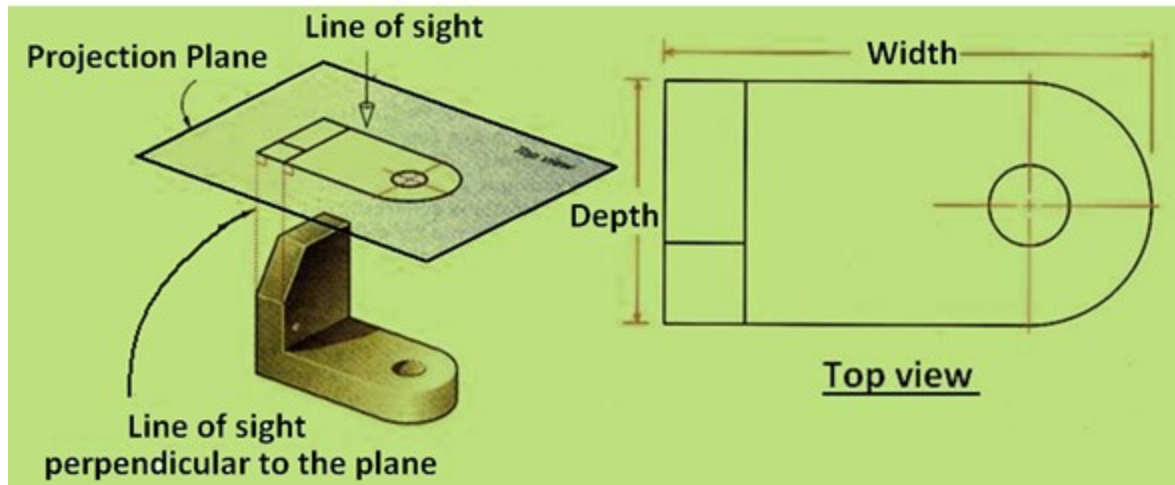

Figure 9 illustrates the method of obtaining the Top view of an object.

### Profile plane of projection

In multi-view drawings, the right side view is the standard side view used and is illustrated in figure 10. The right side view of an object shows the depth and the height dimensions. The right side view is projected onto the profile plane of projection, which is a plane that is parallel to the right side of the object.

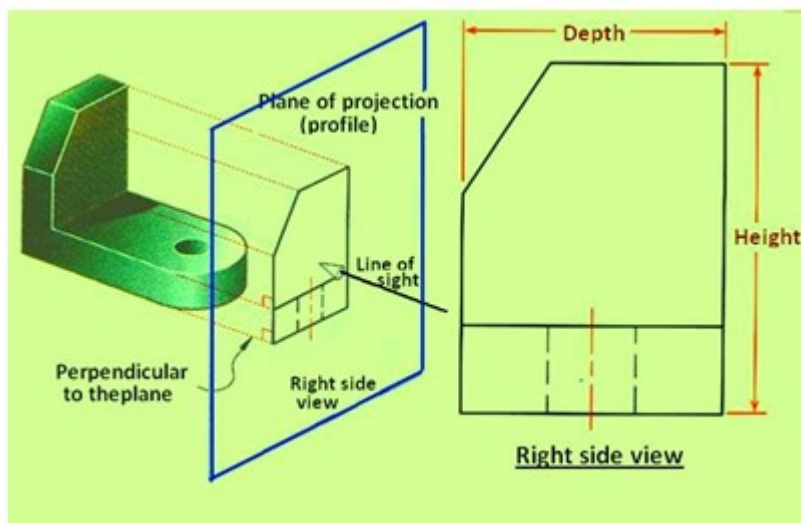

Figure 10 illustrates the method of obtaining the Side View of an object.

### Orientation of views from projection planes

Multi-view drawings gives the complete description of an object. For conveying the complete information, all the three views, i.e., the Front view, Top view and side view of the object is required. To obtain all the technical information, at least two out of the three views are required. It is also necessary to position the three views in a particular order. Top view is always positioned and aligned with the front view, and side view is always positioned to the side of the Front view and aligned with the front view. The positions of each view is shown in figure 11. Depending on whether 1<sup>st</sup> angle or 3<sup>rd</sup> angle projection techniques are used, the top view and Front view will be interchanged. Also the position of the side view will be either towards the Right or left of the Front view.

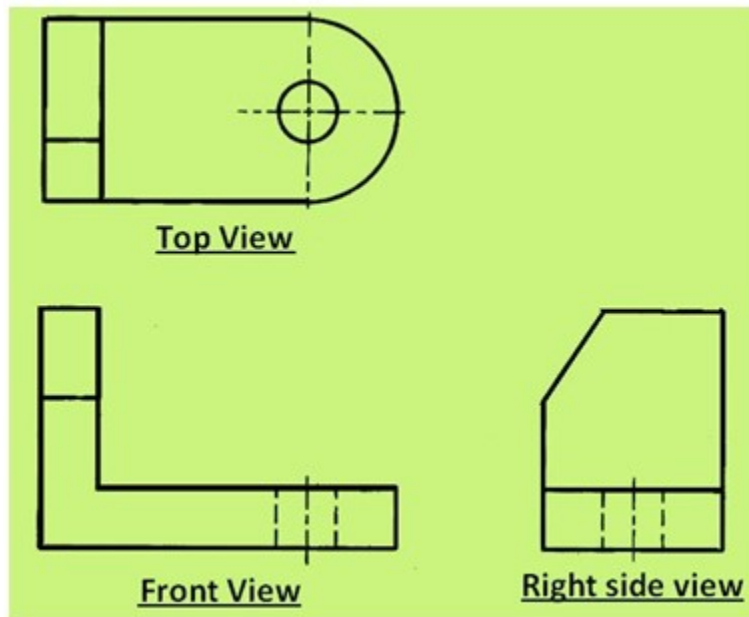

Figure 11. Relative positions and alignment of the views in a multi-view drawing.

### **Six Principal views**

The plane of projection can be oriented to produce an infinite number of views of an object. However, some views are more important than others. These principal views are the six mutually perpendicular views that are produced by six mutually perpendicular planes of projection and is shown in figure 12. Imagine suspending an object in a glass box with major surfaces of the object positioned so that they are parallel to the sides of the box, six sides of the box become projection planes, showing the six views – front, top, left, right, bottom and rear.

Object is suspended in a glass box producing six principal views: each view is perpendicular to and aligned with the adjacent views.

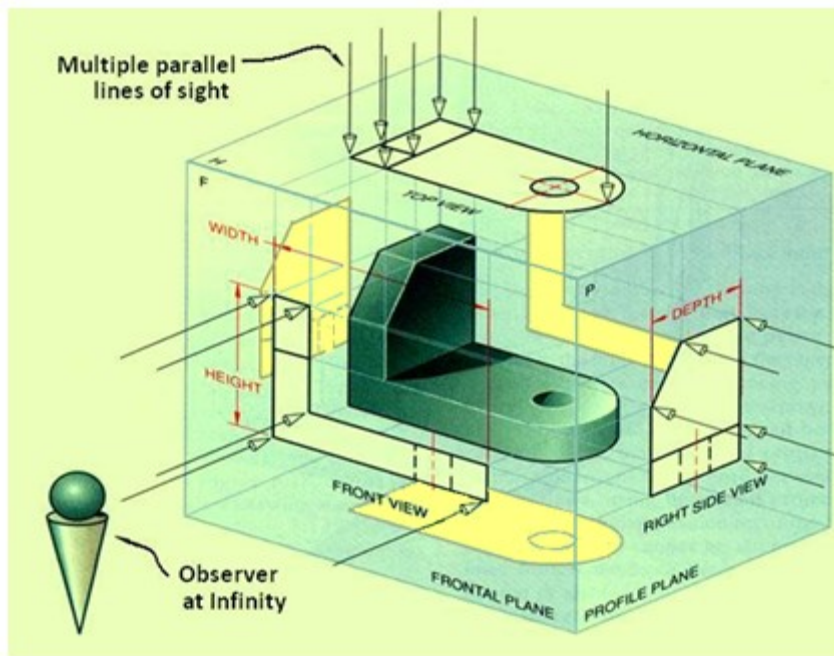

Figure 12. Shows the six perpendicular views of an object

The glass box is now slowly unfolded as shown in figure 13. After complete unfolding of the box on to a single plane, we get the six views of the object in a single plane as shown in figure 14. The top, front and bottom views are all aligned vertically and share the same width dimension where as the rear, left side, front and right side views are all aligned horizontally and share the same height dimension.

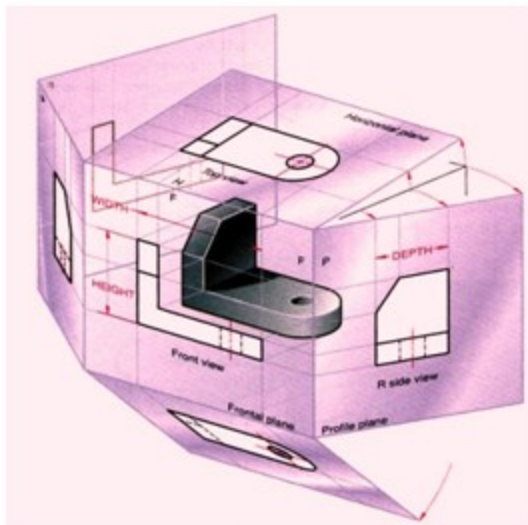

Figure 13. Illustration of the views after the box has been partially unfolded.

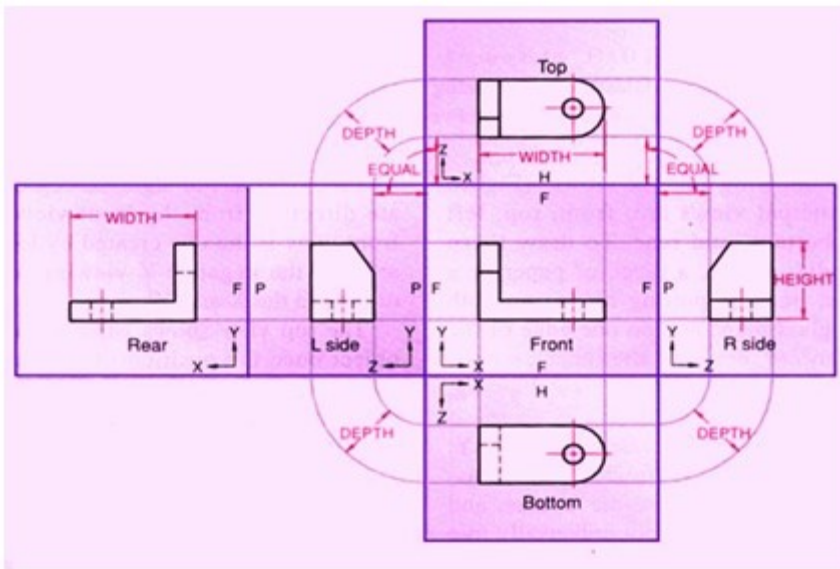

Figure 14 shows the views of the object with their relative positions after the box has been unfolded completely on to a single plane.

### Conventional view placement

The three-view multi-view drawing is the standard used in engineering and technology, because many times the other three principal views are mirror images and do not add to the knowledge about the object. Figure 15 shows the standard views used in a three-view drawing i.e., the top, front and the right side views

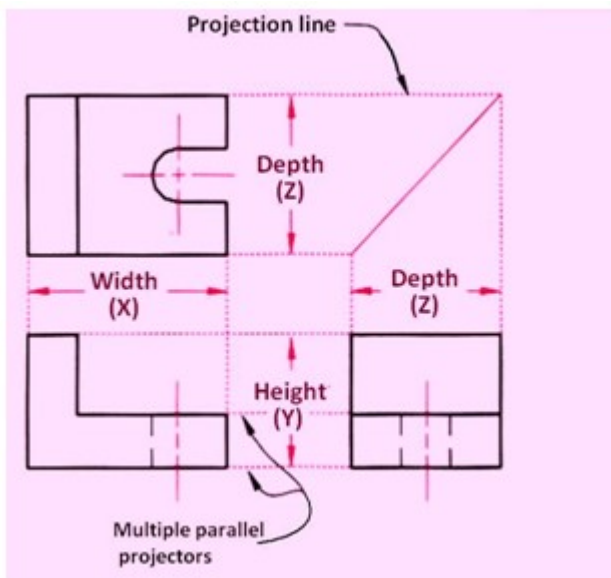

Figure 15 showing the three standard views of a multi-view drawing.

The width dimensions are aligned between the front and top views, using vertical projection lines. The height dimensions are aligned between the front and the profile views, using horizontal projection lines. Because of the relative positioning of the three views, the depth dimension cannot be aligned using projection lines. Instead, the depth dimension is measured in either the top or right side view.

## Projection Methods

Universally either the 1<sup>st</sup> angle projection or the third angle projection methods is followed for obtaining engineering drawings. The principal projection planes and quadrants used to create drawings are shown in figure 16. The object can be considered to be in any of the four quadrant.

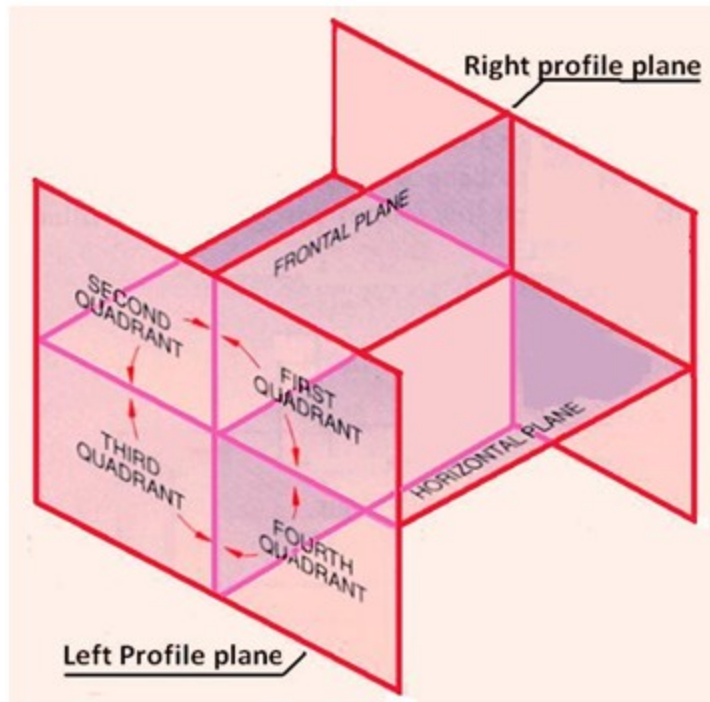

Figure 16. The principal projection planes and quadrants for creation of drawings.

## First Angle Projection

In this the object is assumed to be positioned in the first quadrant and is shown in figure 17. The object is assumed to be positioned in between the projection planes and the observer. The views are obtained by projecting the images on the respective planes. Note that the right hand side view is projected on the plane placed at the left of the object. After projecting on to the respective planes, the bottom plane and left plane is unfolded on to the front view plane. i.e. the left plane is unfolded towards the left side to obtain the Right hand side view on the left side of the Front view and aligned with the Front view. The bottom plane is unfolded towards the bottom to obtain the Top view below the Front view and aligned with the Front View.

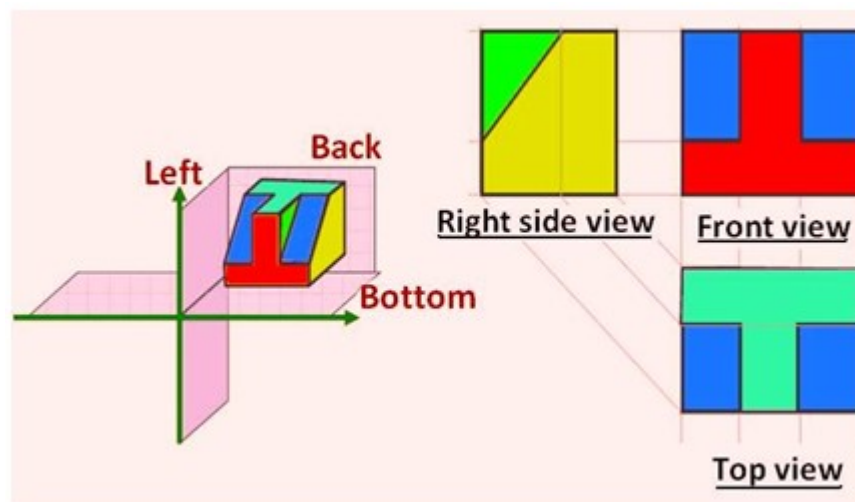

Figure 17. Illustrating the views obtained using first angle projection technique.

### Third Angle Projection

In the third angle projection method, the object is assumed to be in the third quadrant. i.e. the object behind vertical plane and below the horizontal plane. In this projection technique, Placing the object in the third quadrant puts the projection planes between the viewer and the object and is shown in figure 18.

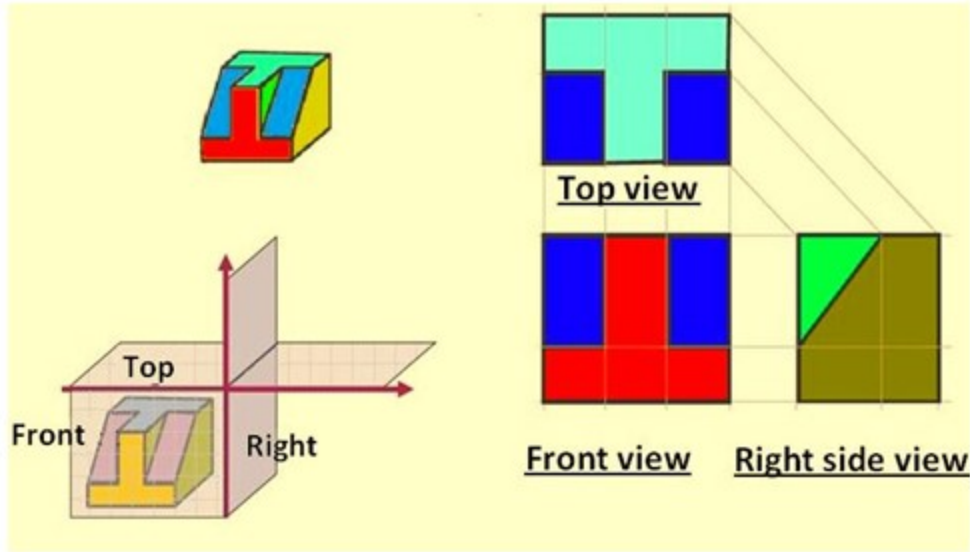

Figure 18. Illustrating the views obtained using first angle projection technique

Figure 19 illustrates the difference between the 1<sup>st</sup> angle and 3<sup>rd</sup> angle projection techniques. A summary of the difference between 1st and 3rd angle projections is shown in Table 1.

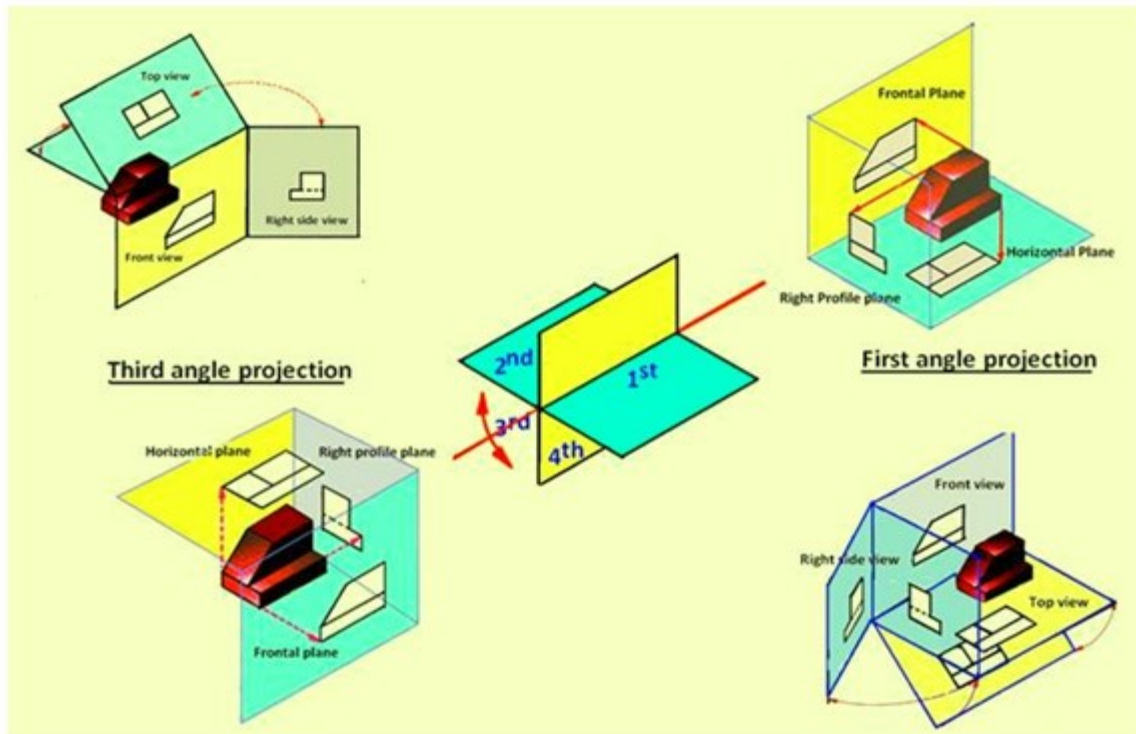

Figure 19 Differentiating between the 1<sup>st</sup> angle and 3<sup>rd</sup> angle projection techniques.

**Table 1. Difference between first- and third-angle projections**

<b>First angle projection</b>	<b>Third-angle projection</b>
Object is kept in the first quadrant.	Object is assumed to be kept in the third quadrant.
Object lies between observer and the plane of projection.	Plane of projection lies between the observer and the object.
The plane of projection is assumed to be non-transparent.	The plane of projection is assumed to be transparent.
Front (elevation) view is drawn above the XY line	Front (elevation) view is drawn below the XY line
Top (plan) view is drawn below the XY line	Top (plan) view is drawn above the XY line
Left view is projected on the right plane and vice versa	Left view is projected on the left plane itself.
Followed in India, European countries	Followed in USA

Either first angle projection or third angle projection are used for engineering drawing. Second angle projection and fourth angle projections are not used since the drawing becomes

complicated. This is being explained with illustrations in the lecture on Projections of points (lecture 18).

### Symbol of projection

The type of projection obtained should be indicated symbolically in the space provided for the purpose in the title box of the drawing sheet. The symbol recommended by BIS is to draw the two sides of a frustum of a cone placed with its axis horizontal. The left view is drawn.

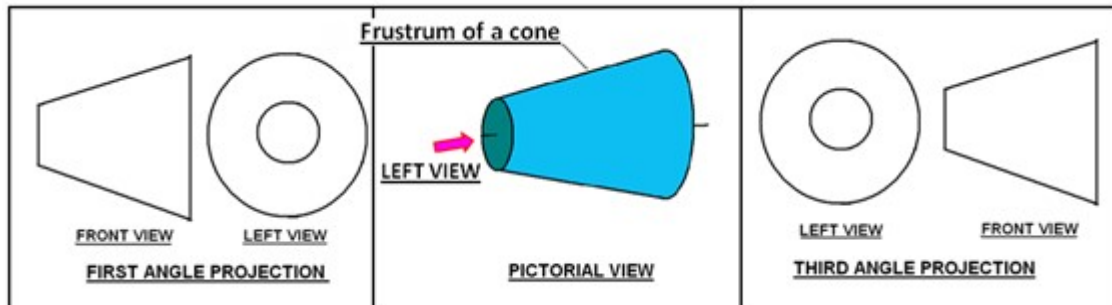

### Orthographic Projections

Lines are used to construct a drawing. Various type of lines are used to construct meaningful drawings. Each line in a drawing is used to convey some specific information. The types of lines generally used in engineering drawing is shown in Table-1.

Table -1. Types of lines generally used in drawings

a) Visible lines	
b) Hidden lines	
c) Centre lines	
d) Dimension lines	
e) construction lines	

All visible edges are to be represented by visible lines. This includes the boundary of the object and intersection between two planes. All hidden edges and features should be represented by dashed lines. Figure 1 shows the orthographic front view (line of sight in the direction of arrow) of an object. The external boundary of the object is a rectangle and is shown by visible lines. In Figure-1(a), the step part of the object is hidden and hence shown as dashed lines while for the position of the object shown in figure-1(b), the step part is directly visible and hence shown by the two solid lines.

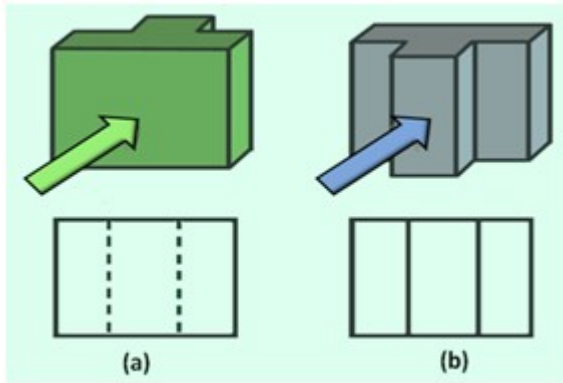

Figure 1 shows the pictorial view and front view of the object when the middle stepped region is (a) hidden and (b) visible.

Figure 2 shows the front view (view along the direction indicated by the arrow) of a solid and hollow cylindrical object. The front view of the solid cylinder is seen as a rectangle (figure 2(a)). For the hollow cylinder in addition to the rectangle representing the boundary of the object, two dashed lines are shown to present the boundary of the hole, which is a hidden feature in the object.

Figure 3 shows the Front view of three objects. Figure 3(a) is the view of one part of a hollow cylinder which has been split in to two equal parts. The wall thickness can be represented by the two visible lines. Figure 3(b) is one part of solid cylinder which has been sectioned in to two equal part. Where as figure 3(c) is one part of a solid cylindrical part which has been split in to two unequal parts. The edge formed by the intersection of two surfaces are represented by solid lines. In case of cylindrical objects or when holes are present in a component, the centre of the holes or centre lines of cylinder will have to be represented in the drawing by means of centre lines as shown in figure 4. Figure 5 shows the FV, TV, and RHSV of an object showing visible edges, hidden edges (or holes), and centre lines.

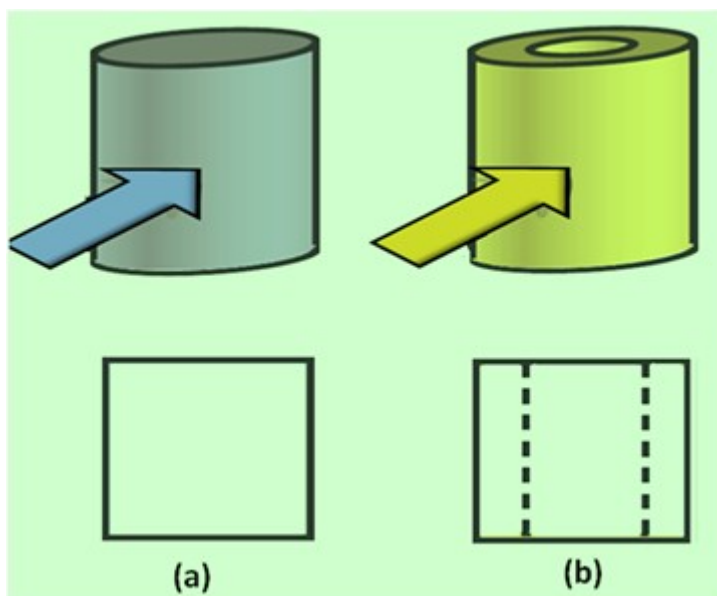

Figure 2 shows the pictorial view and front view of (a) a hollow cylindrical object and (b) solid cylindrical object.

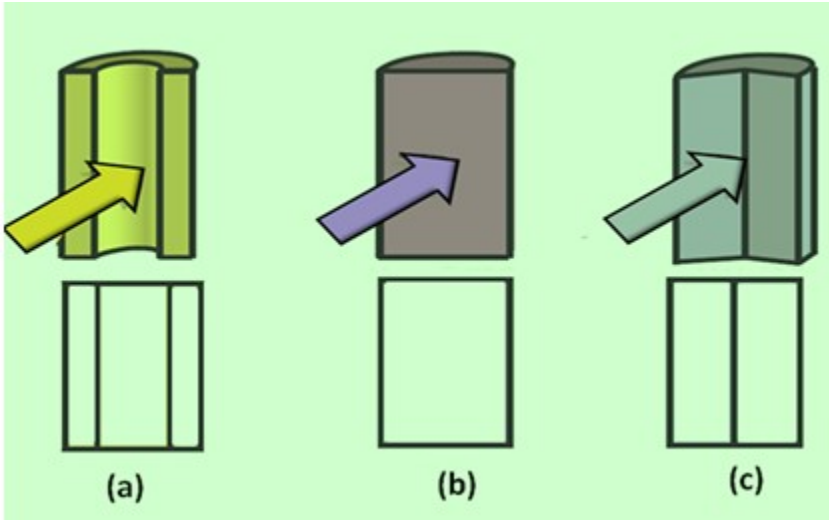

Figure 3 shows the pictorial view and front view of sectioned part of (a) a hollow cylindrical object (b) solid cylindrical object and (c) solid cylinder split in to two unequal parts.

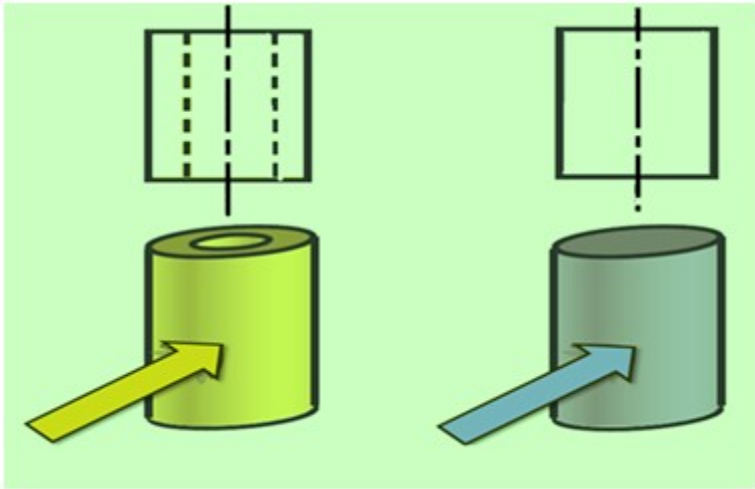

Figure 4 shows the centre lines for cylindrical objects

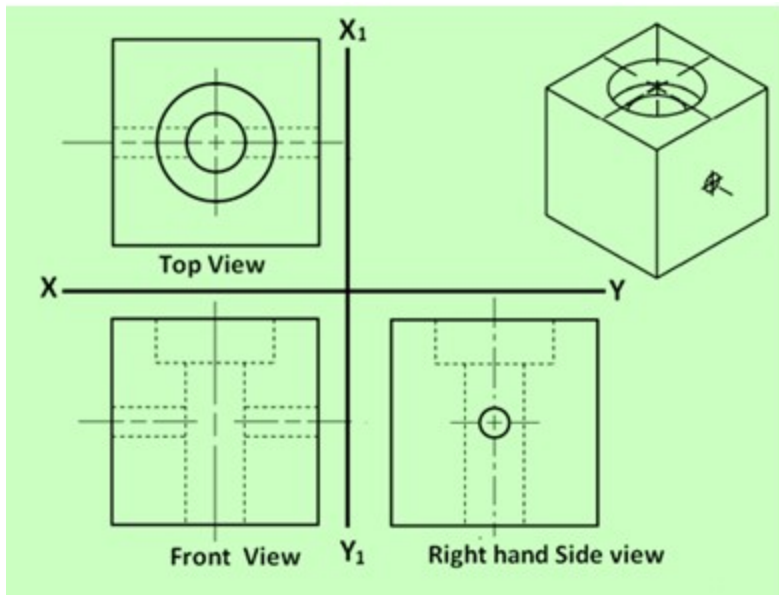

Figure 5. Showing TV, FV and RHSV of an object showing the three types of lines mentioned above. The pictorial view of the object is shown at the top right hand side.

### Conventions used for lines

In orthographic projections, many times different types of lines may fall at the same regions. In such cases, the following rules for precedence of lines are to be followed:

- *Visible lines* take precedence over all other lines
- *Hidden lines* take precedence over center lines
- *Center lines* have lowest precedence

When a visible line and a hidden line are to be drawn at the same area, It will be shown by the visible line only and no hidden line will be shown. Similarly, in case of hidden line and centre line, only hidden line will be shown. In such case, the centre line will be shown only if it is extending beyond the length of the hidden line.

### Intersecting Lines in Orthographic Projections

The conventions used when different lines intersect is shown in figure - 6(a) & (b).

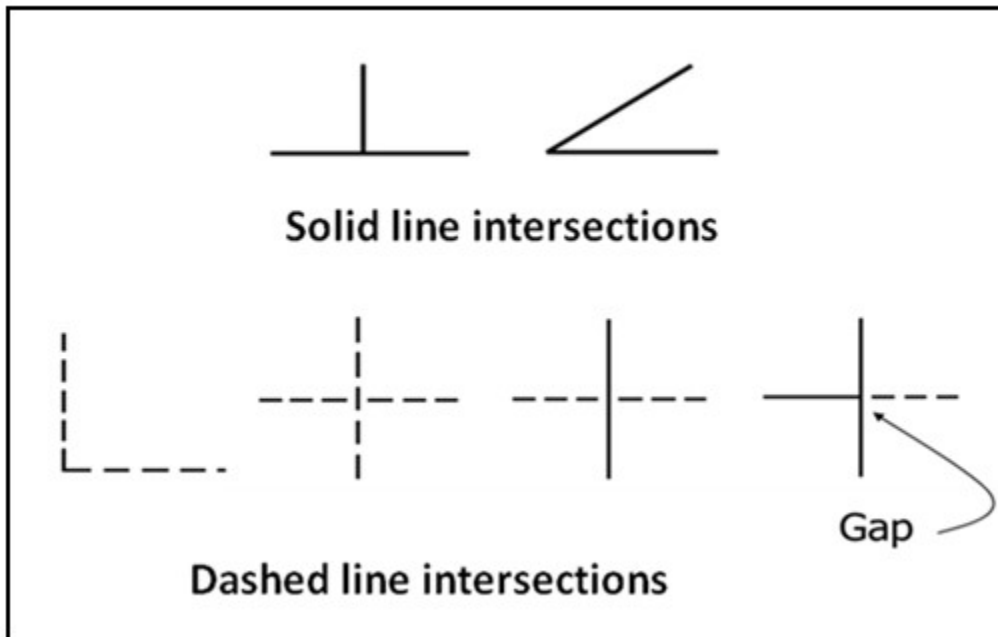

Figure 6(a): The conventions practiced for intersection lines.

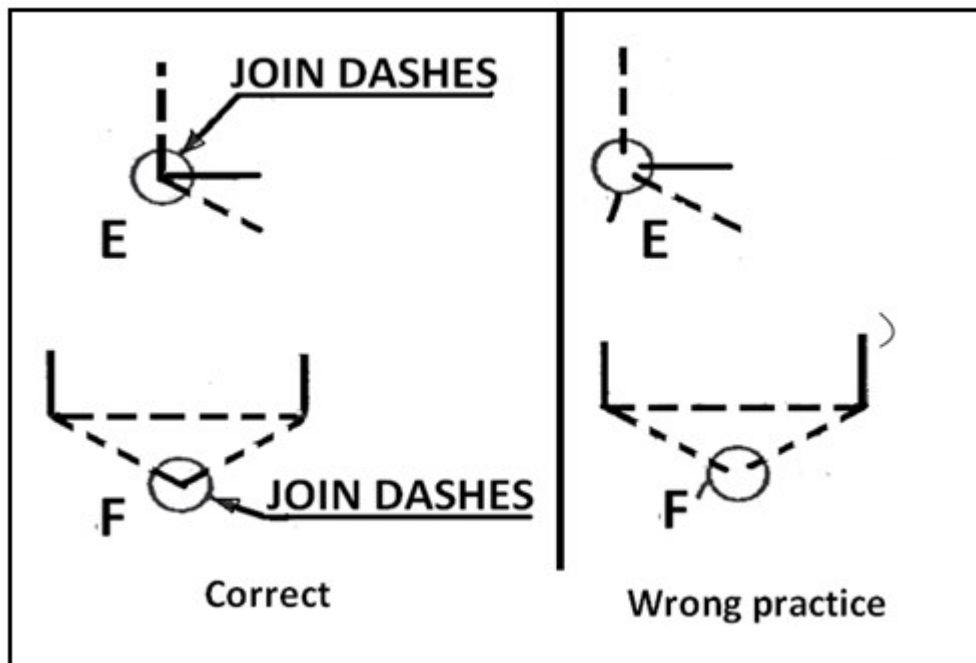
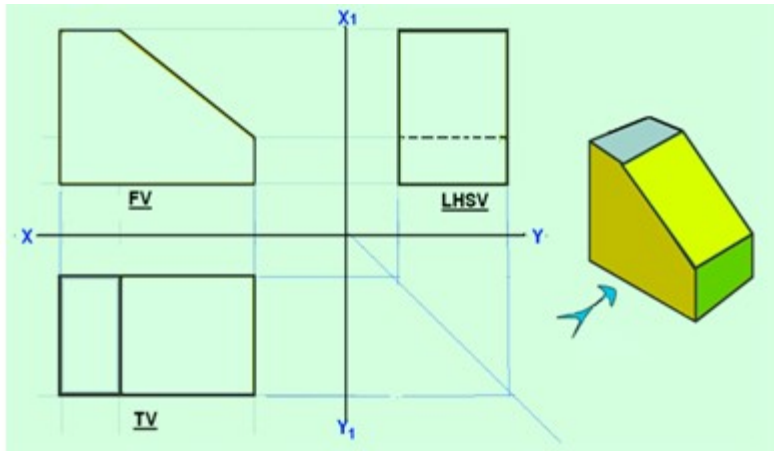
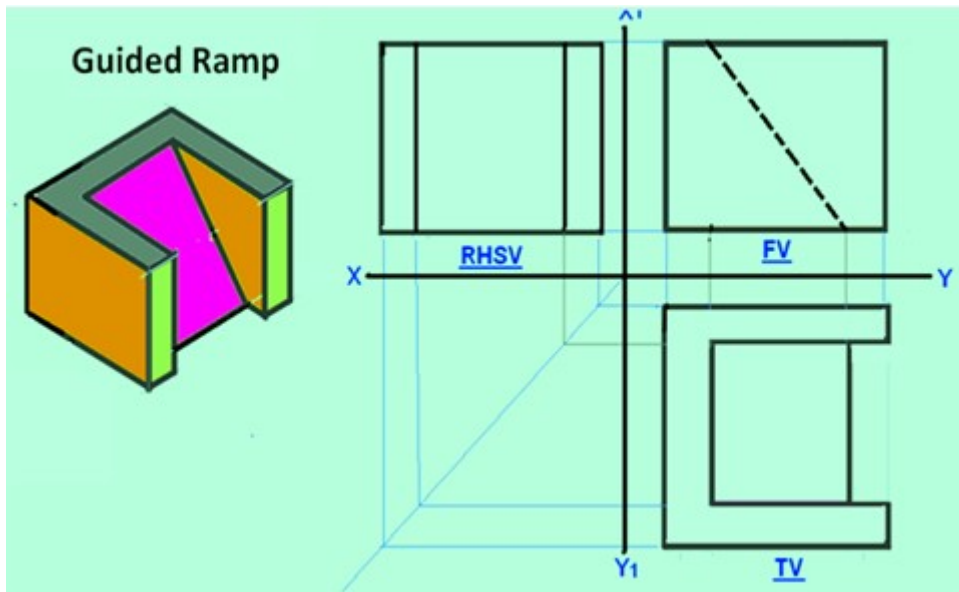

Figure 6(b): The conventions practiced for intersection lines.

Some ortho graphic projections of solids showing the different lines and their precedence are shown as examples below. The 3-D view of the respective objects are also shown in the figures with the direction of arrow representing the line of sight in the front view. A few examples of the projections showing the conventions in drawing are presented below.



Example 1



Example 2

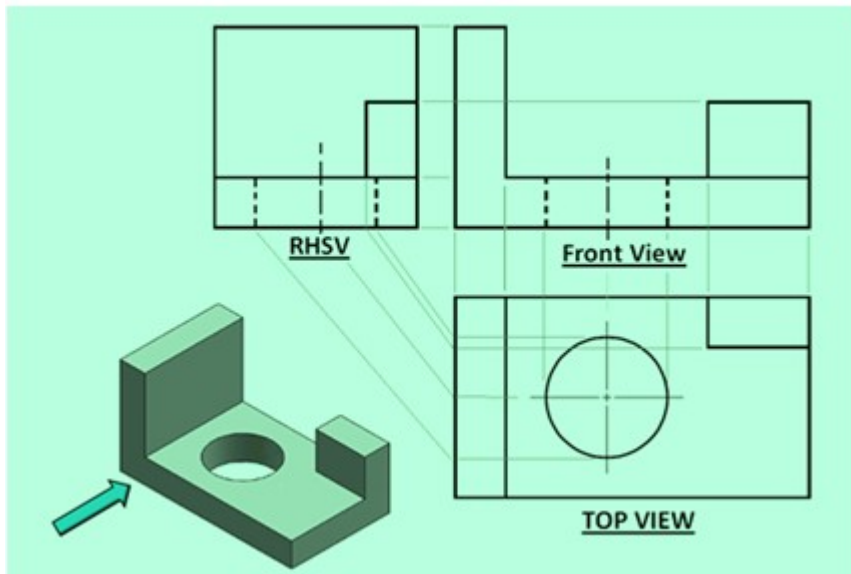

Example 3

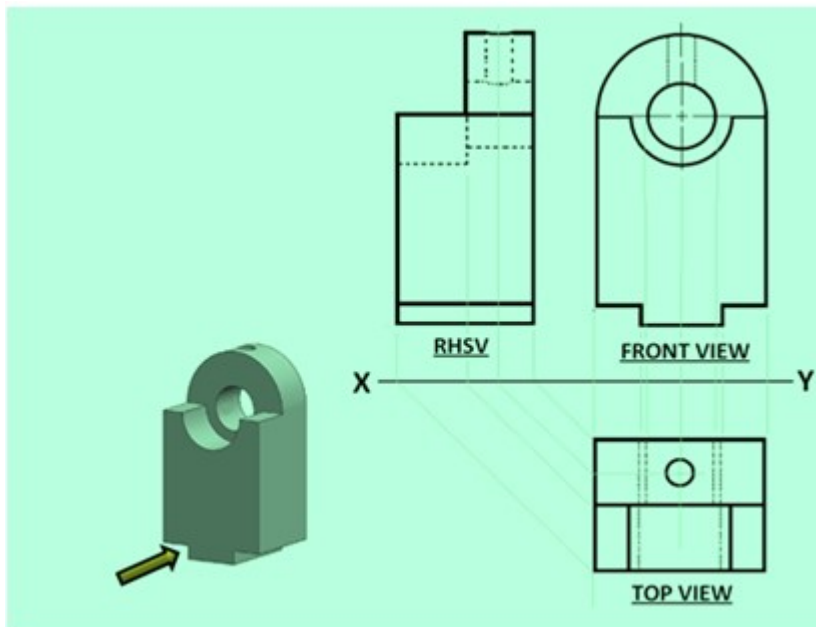

Example 4

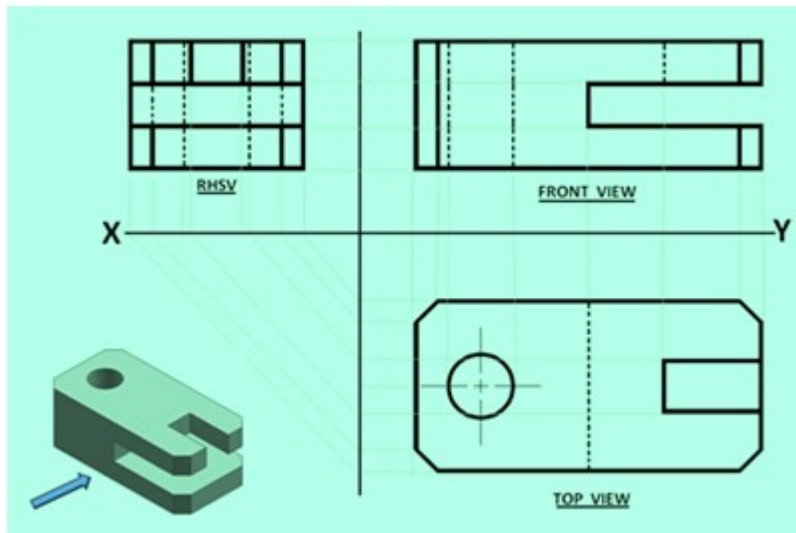

Example 5

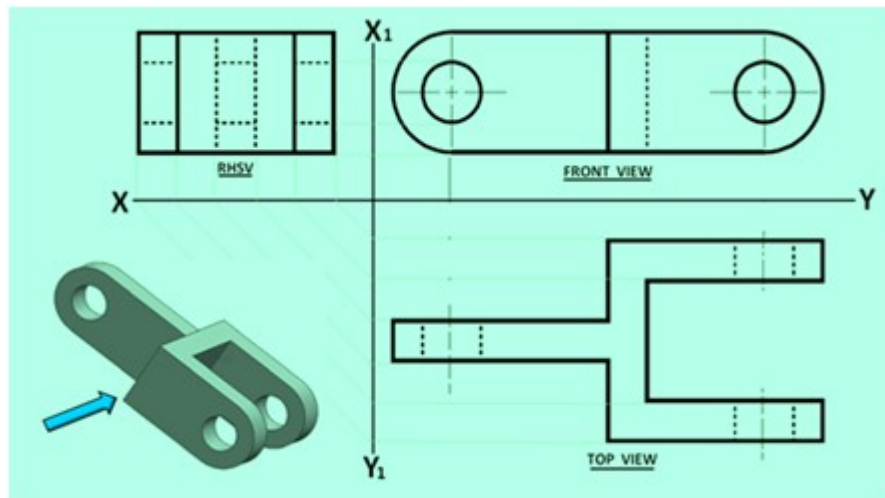

Example 6

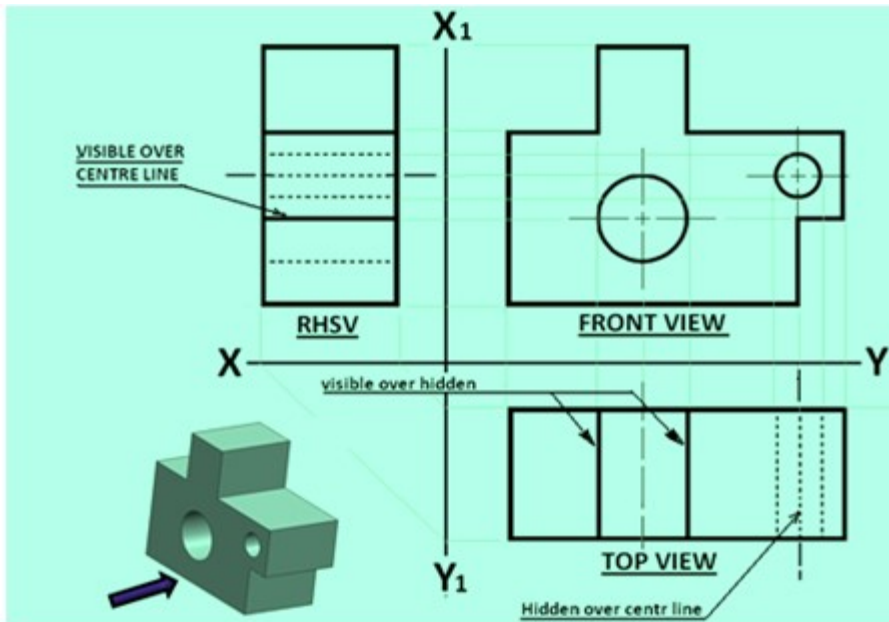

**Example 7**

**Example 8 (application of Precedence rule)**

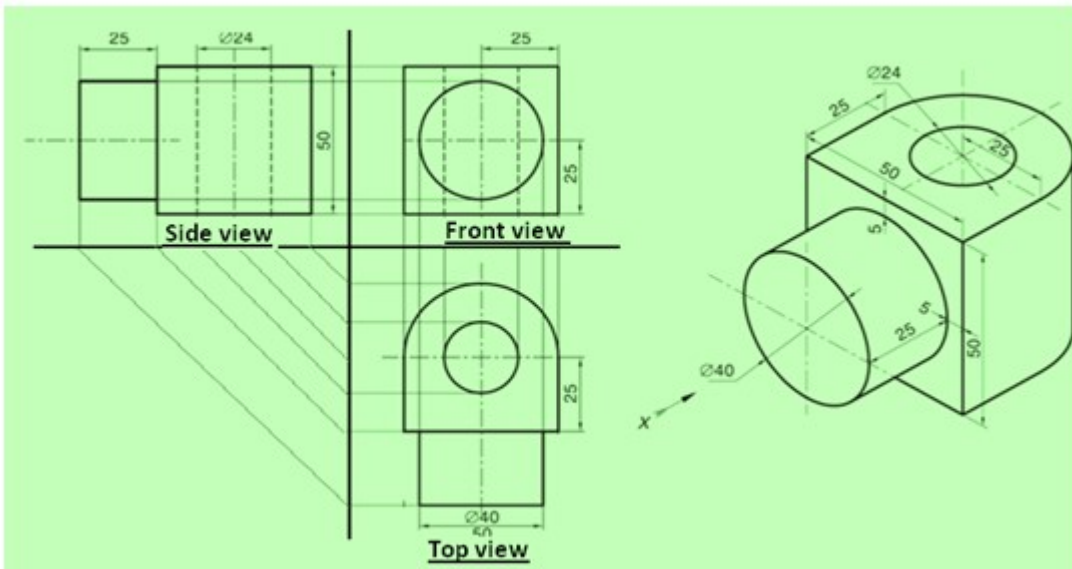

**Example 9 (Objects with circular features : holes, flanges, etc )**

**Projection of Points**

**A POINT**

The position of a point in engineering drawing is defined with respect to its distance from the three principle planes i.e., with respect to the VP, HP, & PP. The point is assumed to be in the respective quadrant shown in figure 1(a). The point at which the line of sight (line of sight is

normal to the respective plane of projection) intersects the three planes are obtained. The horizontal plane and the side planes are rotated so such that they lie on the plane containing the vertical plane. The direction of rotation of the horizontal plane is shown in figure 1 (b).

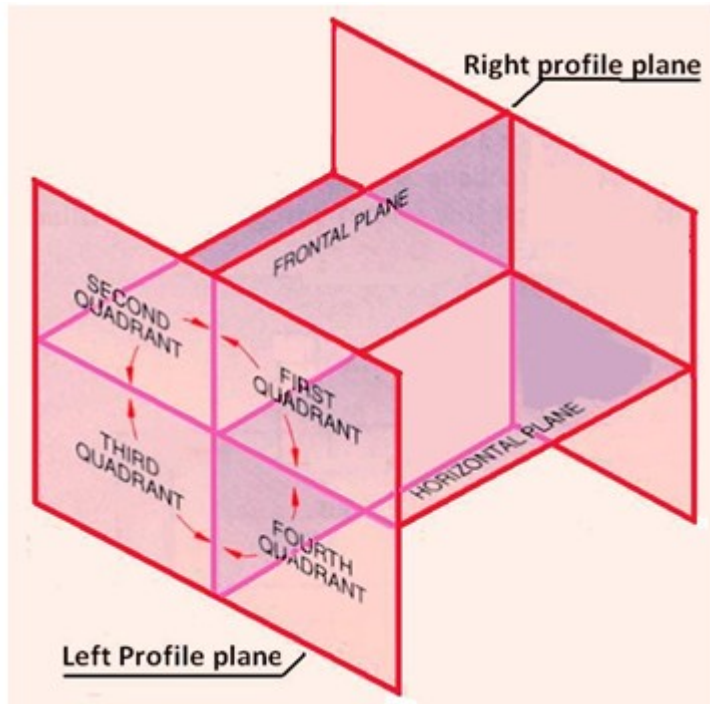

Figure 1(a). The relative positions of projection planes and the quadrants

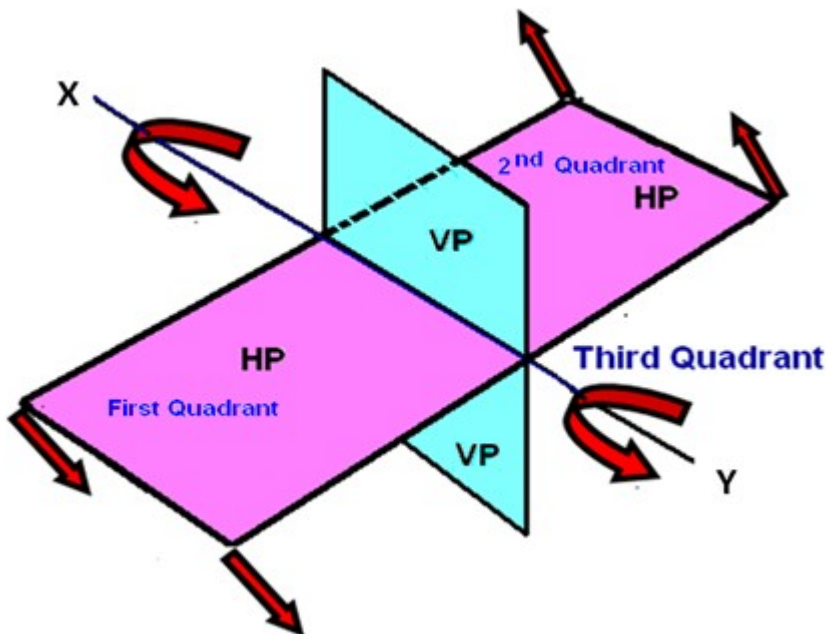

Figure 1(b). The direction of rotation of the Horizontal plane.

Conventions used while drawing the projections of points

With respect to the 1<sup>st</sup> angle projection of point “P” shown in figure 2,

- Top views are represented by only small letters eg. p .
- Their front views are conventionally represented by small letters with dashes eg. p’
- Profile or side views are represented by small letters with double dashes eg. p’’
- Projectors are shown as thin lines.

- The line of intersection of HP and VP is denoted as X-Y.
- The line of intersection of VP and PP is denoted as X1-Y1

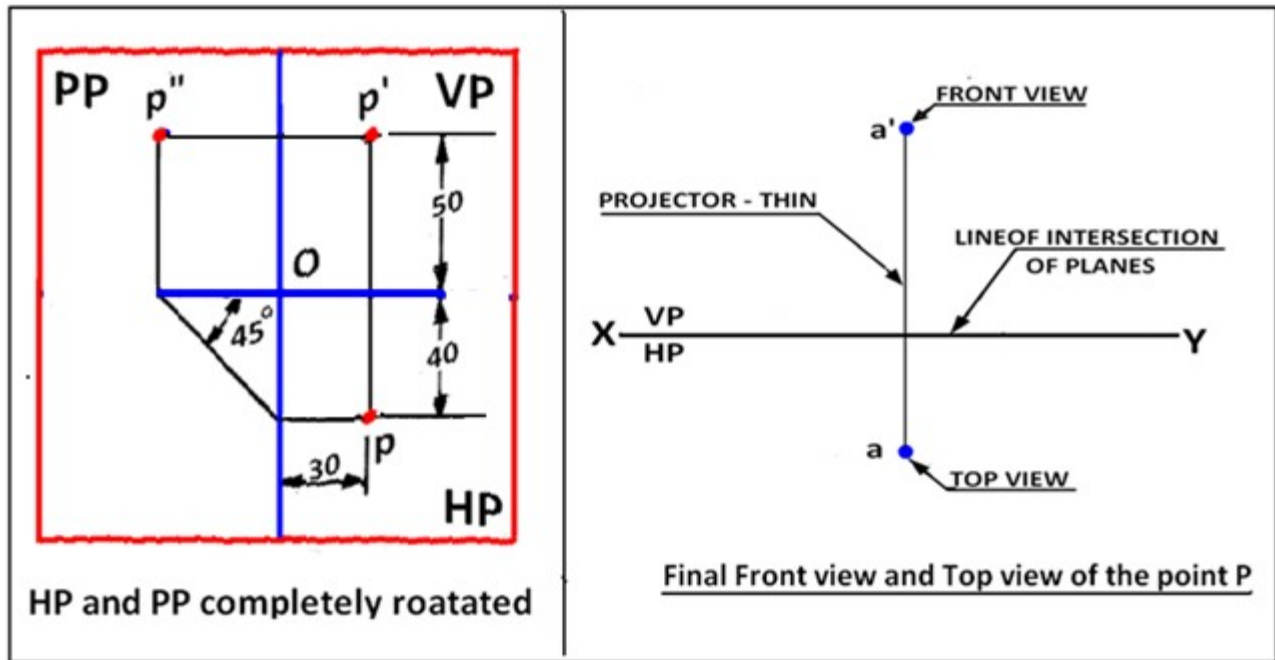

Figure 2. Showing the three planes and the projection of the point P after the planes have been rotated on to the vertical plane.

### Point in the First quadrant

Figure 3 shown the projections of a point P which is 40 mm in front of VP, 50 mm above HP, 30 mm in front of left profile plane (PP)

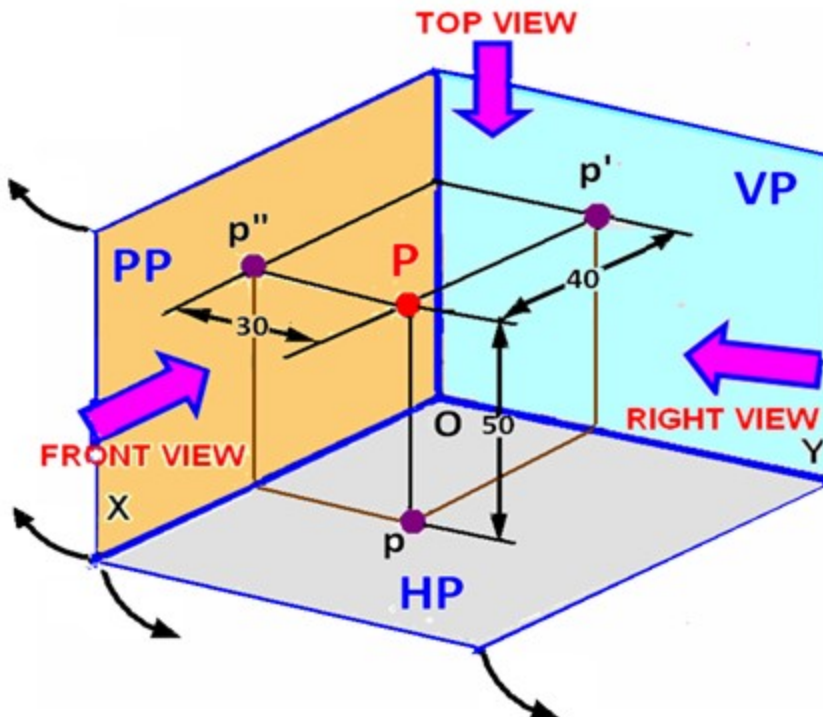

Figure 3. Projection of the point “P” on to the three projection planes before the planes are rotated.

Figure 4 shows the planes and the position of the points when the planes are partially rotated. The arrows indicate the direction of rotation of the planes. The three views after complete rotation of the planes is shown in figure 2.

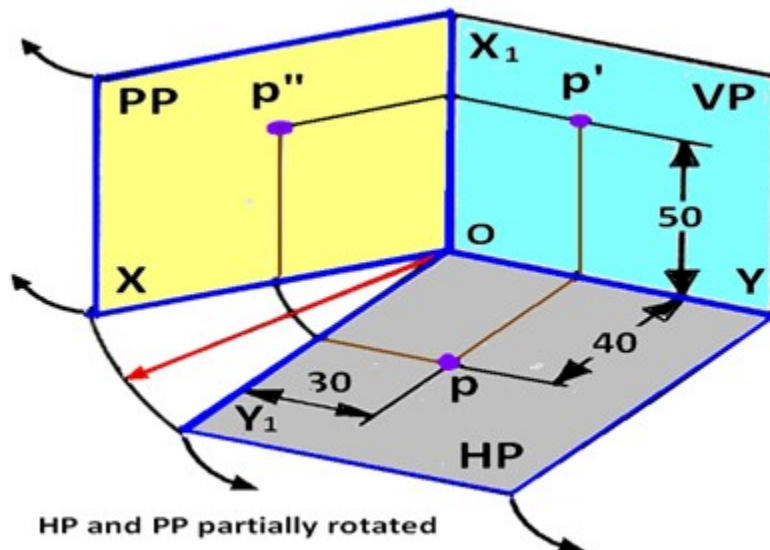

Figure 4. Projection of the point “P” on to the three projection planes after the planes are partially rotated.

The procedure of drawing the three views of the point “P” is shown in figure-4.

- Draw a thin horizontal line, XY, to represent the line of intersection of HP and VP.
- Draw X<sub>1</sub>Y<sub>1</sub> line to represent the line of intersection of VP and PP.
- Draw the Top View (p).
- Draw the projector line
- Draw the Front View (p').
- To project the right view on the left PP, draw a horizontal projector through p to intersect the 45 degree line at m. Through m draw a vertical projector to intersect the horizontal projector drawn through p' at p''.
- p'' is the right view of point P

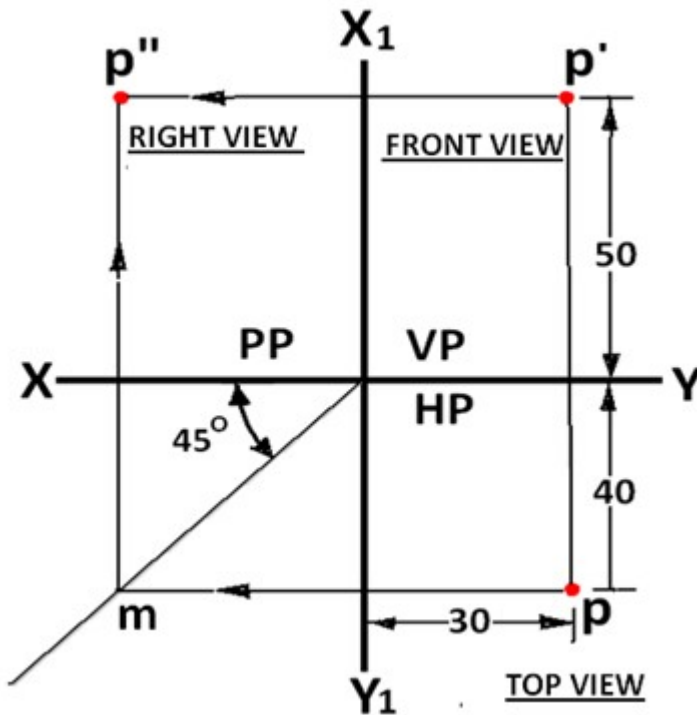

Figure 5 First angle multi-view drawing of the point “P”

### Point in the Second quadrant

Point P is 30 mm above HP, 50 mm behind VP and 45 mm in front of left PP. Since point P is located behind VP, the VP is assumed transparent. The position of the point w.r.t the three planes are shown in Figure 1. The direction of viewing are shown by arrows. After projecting the point on to the three planes, the HP and PP are rotated such that they lie along the VP. The direction of rotation of the HP and PP is shown in figure 2. As shown in figure 3, after rotation of the PP and HP, it is found that the VP and HP is overlapping. The multiview drawing for the point P lying in the second quadrant is shown in figure 4. Though for the projection of a single point, this may not be a problem, the multiview drawing of solids, where a number of lines are to be drawn, will be very complicated. Hence second angle projection technic is not followed anywhere for engineering drawing.

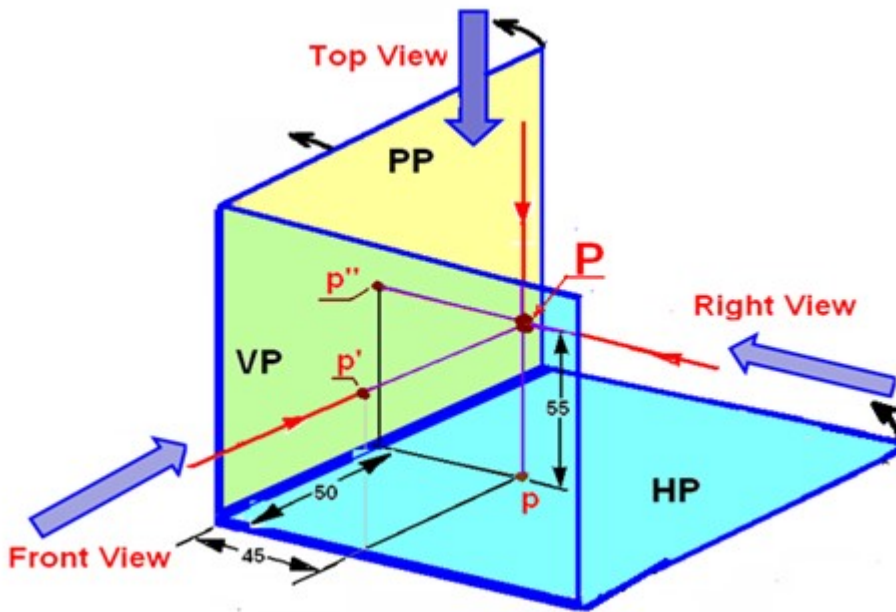

Figure 1. The projection of point P on to the three projection planes.

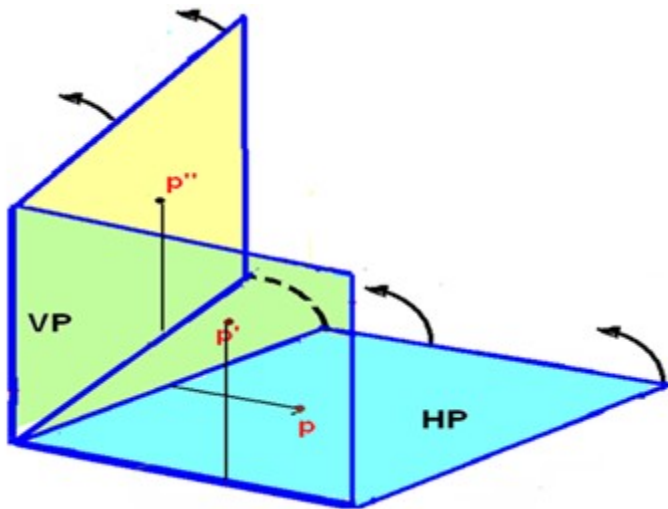

Figure 2. The direction of rotation of HP.

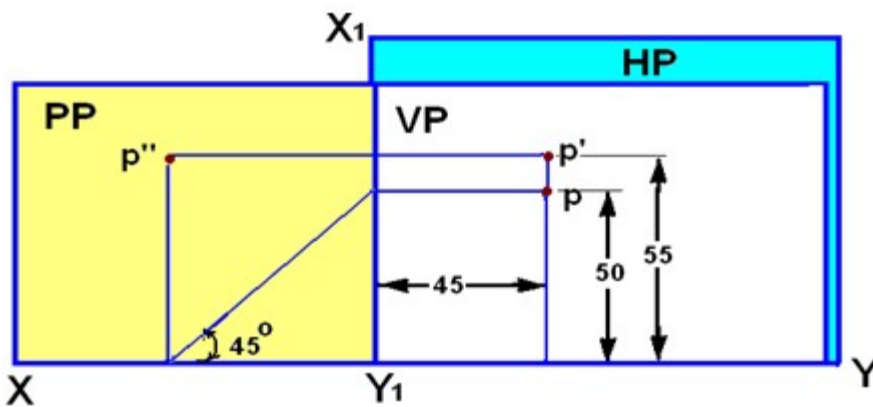
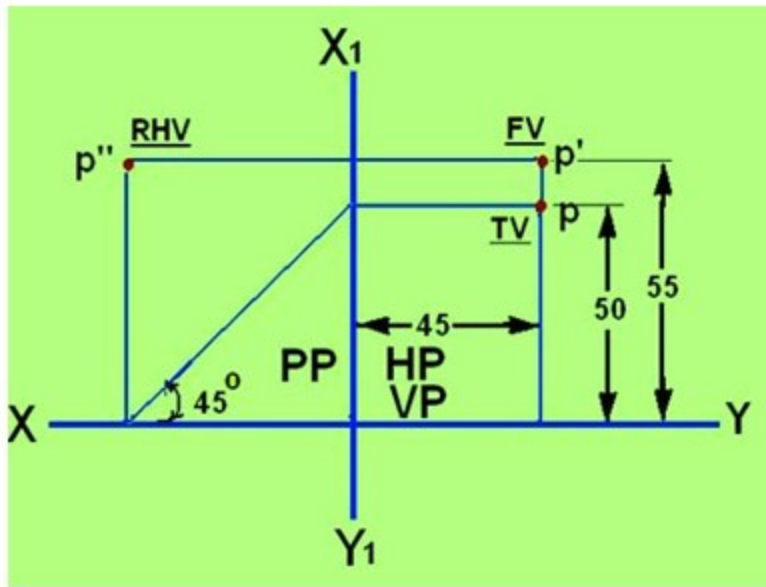

Figure 3. The projection of point P after complete rotation of the HP and PP.

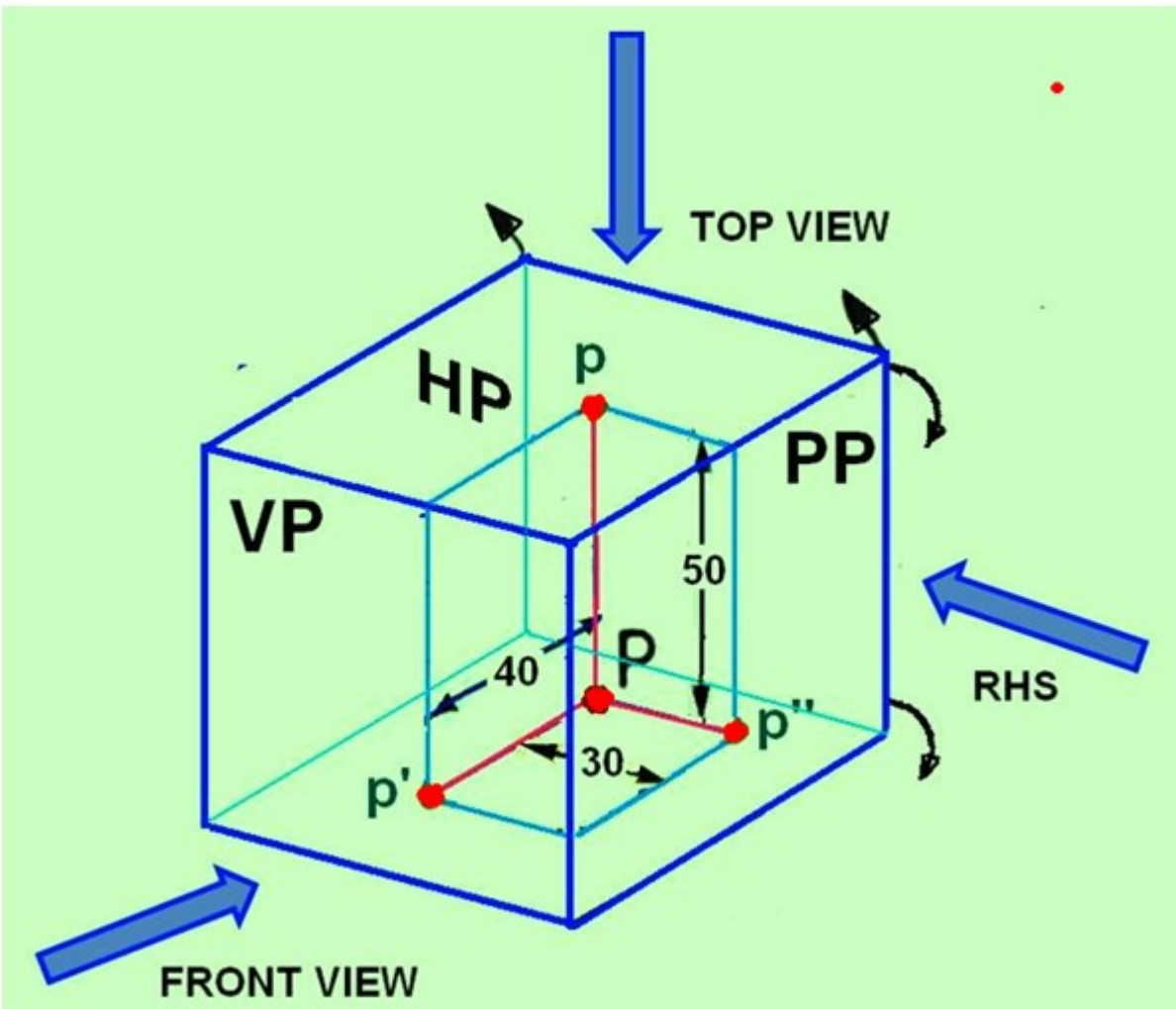

**Figure 4. The multiview drawing of the point P lying in the second quadrant.**

### **Point in the Third quadrant**

Projection of a point P in the third quadrant where P is 40 mm behind VP, 50 mm below HP and 30 mm behind the right PP is shown in figure 5.

Since the three planes of projections lie in between the observer and the point P, they are assumed as transparent planes. After the point P is projected on to the three planes, the HP and VP are rotated along the direction shown in figure 6, such that the HP and VP are in plane with the VP. The orthographic projection of the point P lying in the third quadrant is shown in figure 7.



**Figure 5. Projection of a point P placed in the third quadrant**

In the third angle projection, the Top view is always above the front view and the Right side view will be towards the right of the Front view.

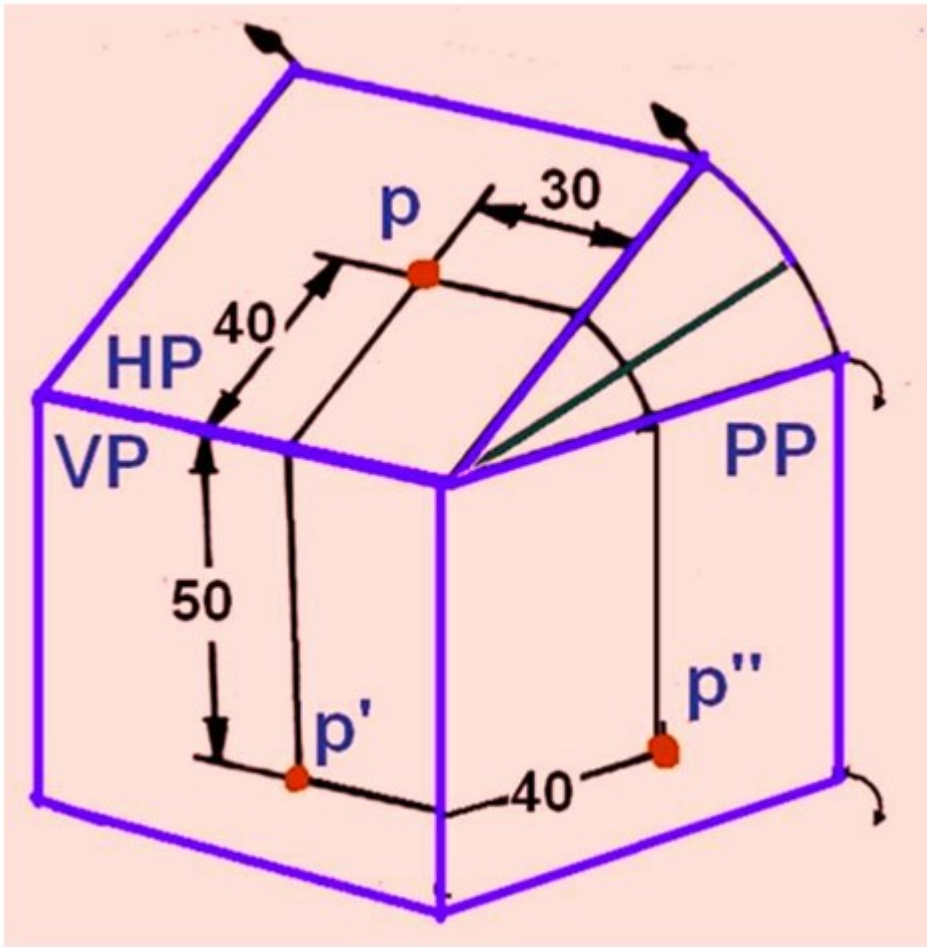
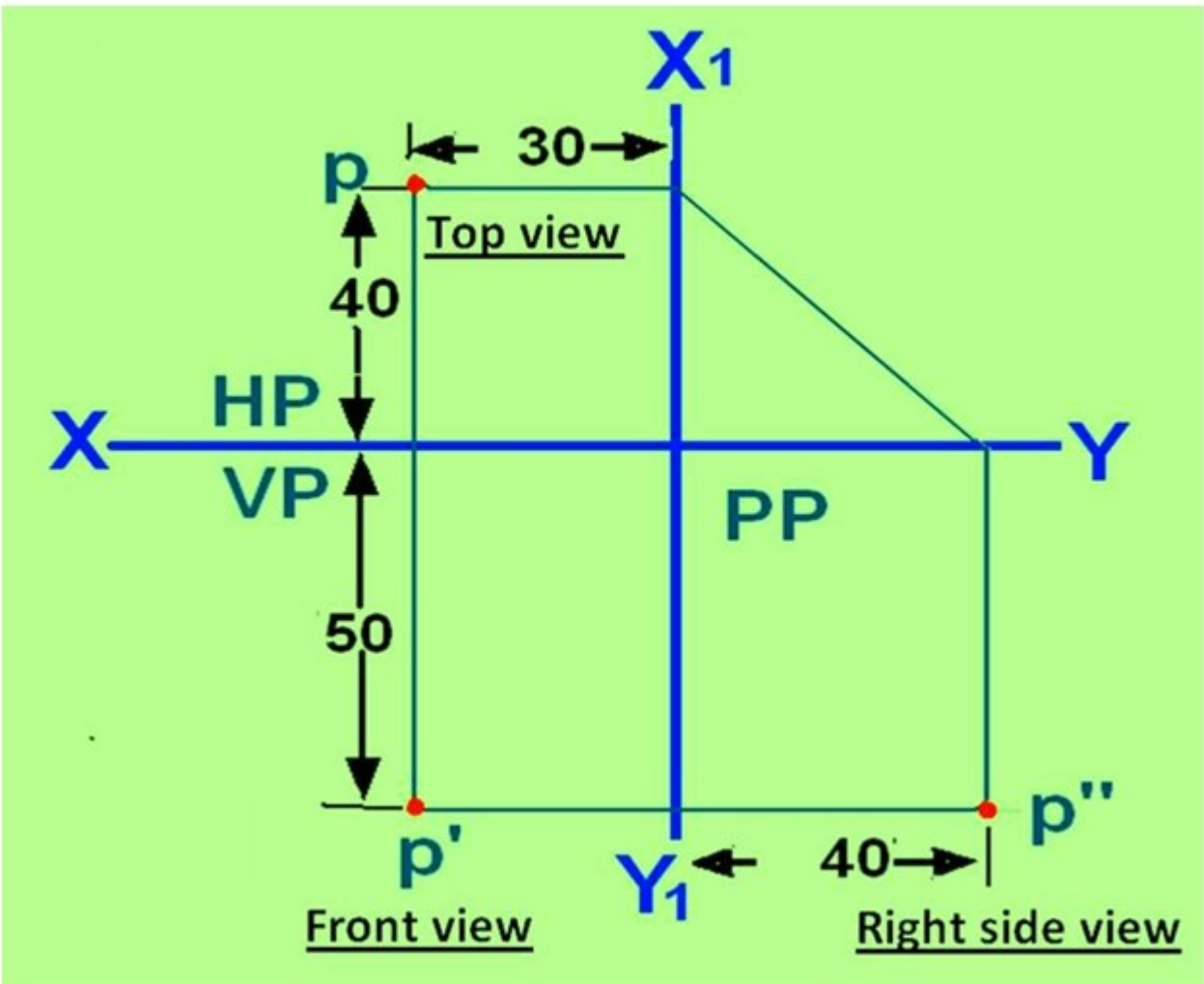

Figure 6. shows the sense of direction of rotation of PP and HP.



**Figure 7. Multi-view drawing of the point lying in the third quadrant.**

In the third angle projection, the Top view is always above the front view and the Right side view will be towards the right of the Front view.

### **Point in the Fourth quadrant**

If A point is lying in the fourth quadrant, the point will be below the HP and in front of the VP. The point is projected on to the respective projection planes. After rotation of the HP and PP on to the VP, it will be observed that the HP and VP are overlapping, similar to the second angle projection. The multi-view drawing of objects in such case would be very confusing and hence fourth angle projection technique is not followed by engineers.

### **Projections of lines**

#### **Straight line**

A line is a geometric primitive that has length and direction, but no thickness. Straight line is the Locus of a point, which moves linearly. Straight line is also the shortest distance between any two given points.

The location of a line in projection quadrants is described by specifying the distances of its end points from the VP, HP and PP. A line may be:

- Parallel to both the planes.
- Parallel to one plane and perpendicular to the other.
- Parallel to one plane and inclined to the other.
- Inclined to both the planes.

### Projection of a line

The projection of a line can be obtained by projecting its end points on planes of projections and then connecting the points of projections. The projected length and inclination of a line, can be different compared to its true length and inclination.

#### Case 1. Line parallel to a plane

When a line is parallel to a plane, the projection of the line on to that plane will be its true length. The projection of line **AB** lying parallel to the Vertical plane (VP) is shown in figure 1 as **a'b'**.

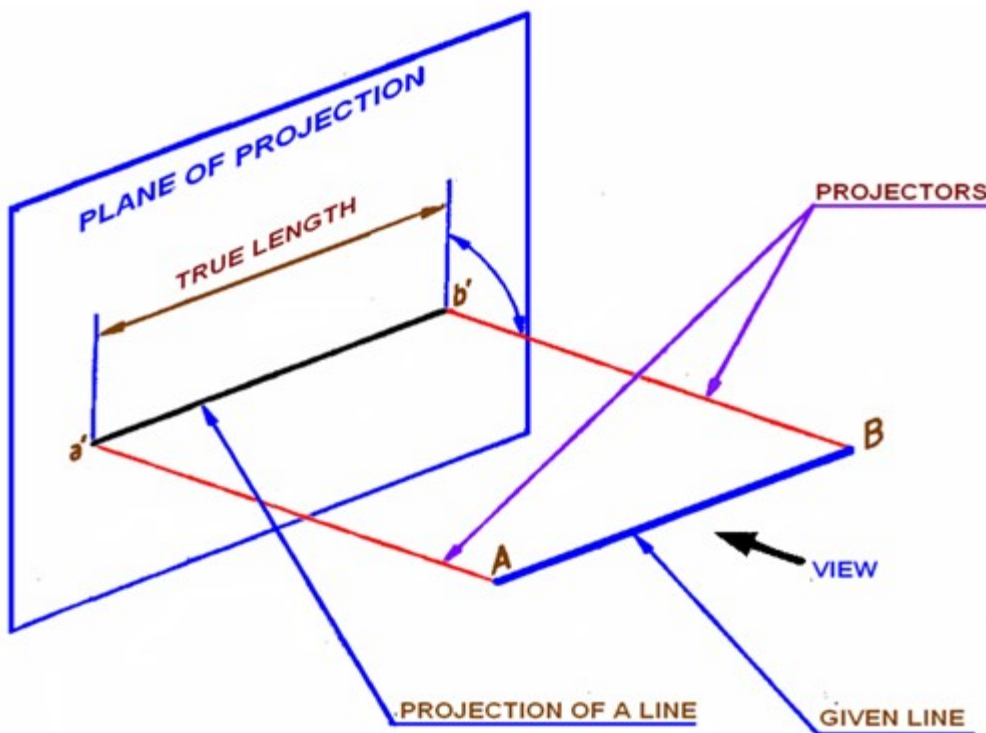

Figure 1. Projection of line on VP. Line AB is parallel to VP.

#### Case 2. Line inclined to a plane

When a line is parallel to one plane and inclined to the other, The projection of the line on the plane to which it is parallel will show its true length. The projected length on the plane to which it is inclined will always be shorter than the true length. In figure 2, the line AB is parallel to VP and is inclined to HP. The angle of inclination of AB with HP is being  $\theta$  degrees. Projection of line AB on VP is a'b' and is the true length of AB. The projection of line AB on HP is indicated as line ab. Length ab is shorter than the true length AB of the line.

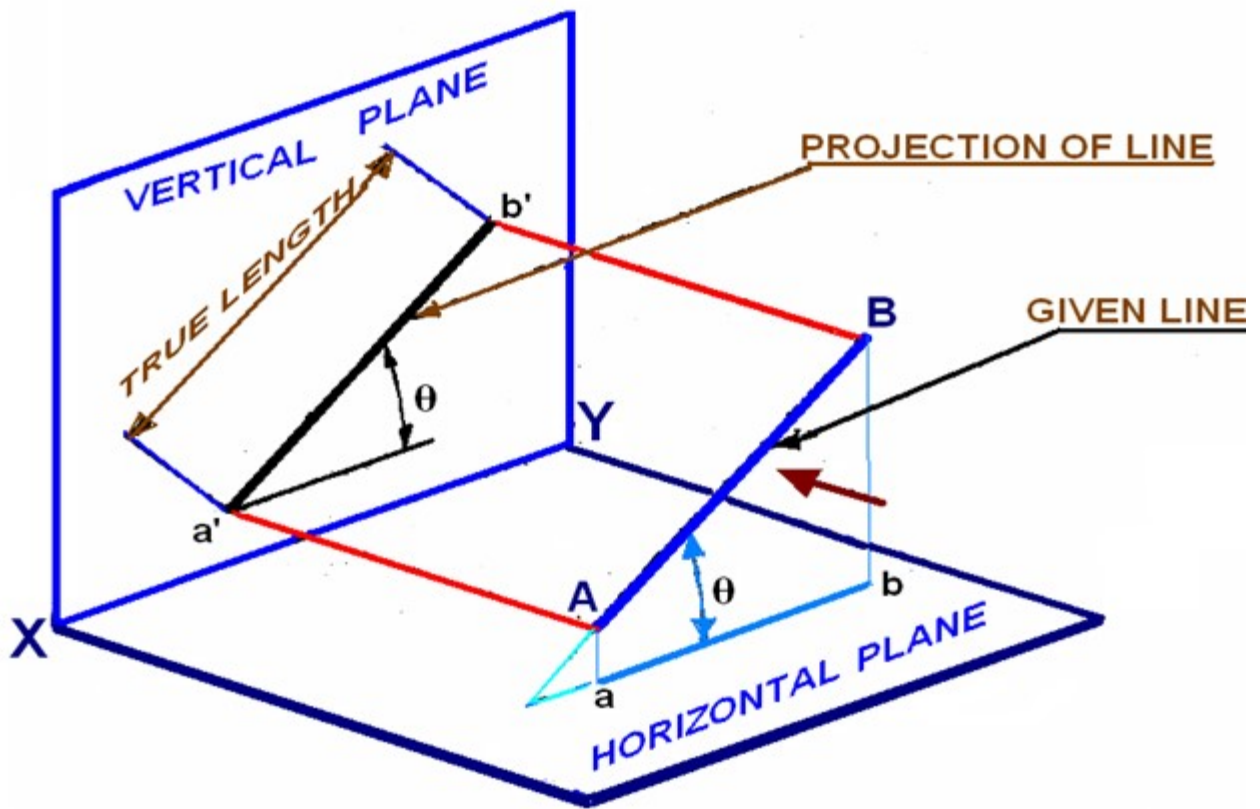

Figure 2. Projection of line AB parallel to VO and inclined to HP.

### Case 3. Projection of a line parallel to both HP and VP

A line AB having length 80 mm is parallel to both HP and VP. The line is 70 mm above HP, 60 mm in front of VP. End B is 30 mm in front of right PP. To draw the projection of line AB, assume the line in the first quadrant. The projection points of AB on the vertical plane VP, horizontal plane HP and Right Profile plane PP is shown in figure 3(a). Since the line is parallel to both HP and VP, both the front view  $a'b'$  and the top view  $ab$  are in true lengths. Since the line is perpendicular to the right PP, the left side view of the line will be a point  $a''(b'')$ . After projection on to the projection planes, the planes are rotated such that all the three projection planes lie in the same planes. The multi-view drawing of line AB is shown in Figure 3(b).

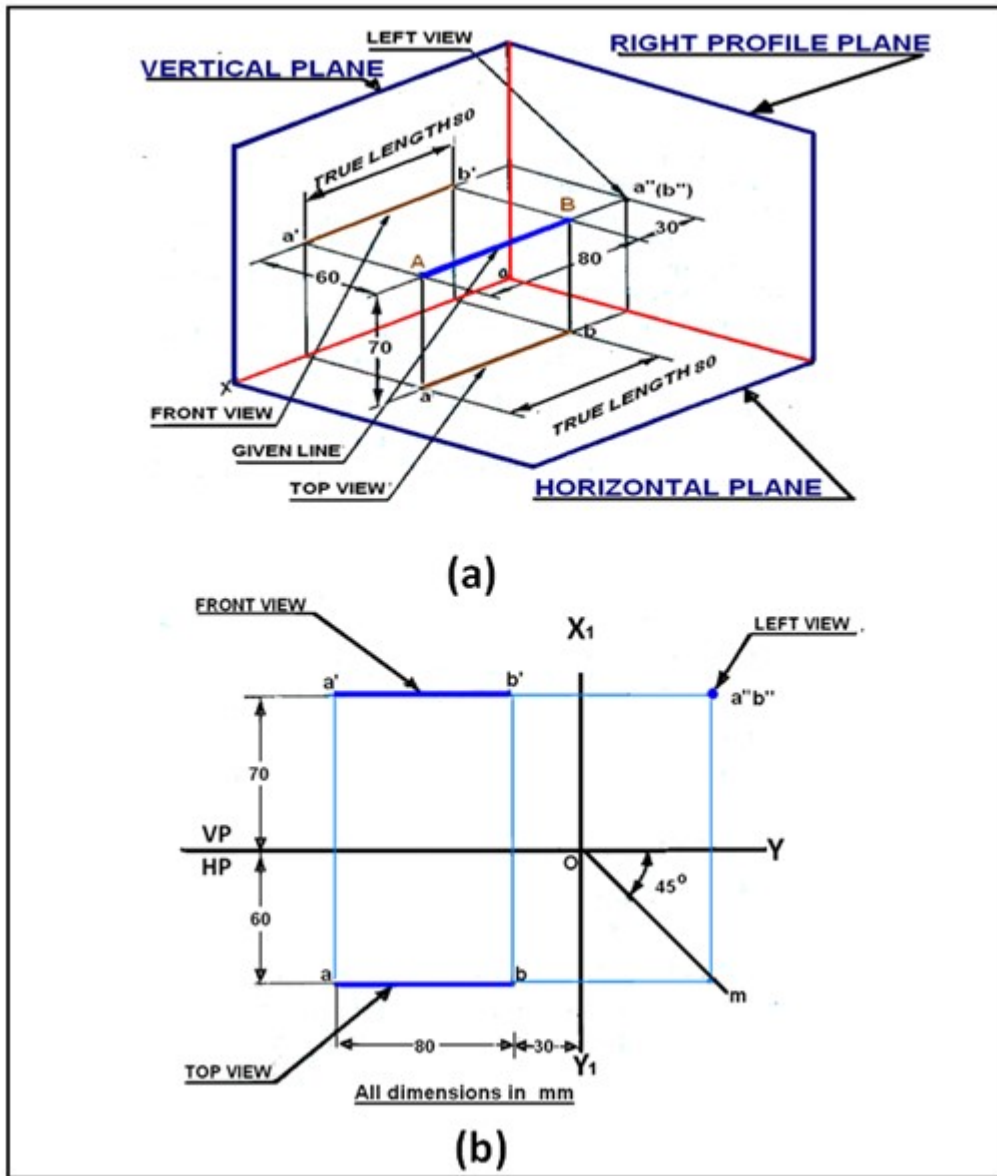

Figure 3. Projection of line parallel to both HP and VP.

#### Case 4. Line perpendicular to HP & parallel to VP

A line AB of length 80 mm is parallel to VP and perpendicular to HP. The line is 80 mm in front of VP and 80 mm in front of right PP. The lower end of the line is 30 mm above HP. The projections of line AB shown in figure 4 can be obtained by the following method.

Draw a line XY which is the intersection between VP and HP. Draw the front view  $a'b' = 80$  mm perpendicular to the XY line, with the lower end  $b'$  lying 30 mm above the XY line. Project the top view of the line which will be a point  $a(b)$  at a distance of 60 mm below XY line. Since the line is 70 mm in front of the right PP draw the  $X_1Y_1$  line at a distance of 70 mm on the right- side of the front view.

Through O the point of intersection of XY and  $X_1Y_1$ , lines draw a  $45^\circ$  line. Draw the horizontal projector through  $a(b)$  to cut the 45 degree line at m. Draw the horizontal projectors through a'

and  $b'$  to intersect the vertical projector drawn through  $m$  at  $a''$  and  $b''$ .  $a''b''$  is the left view of the line AB.

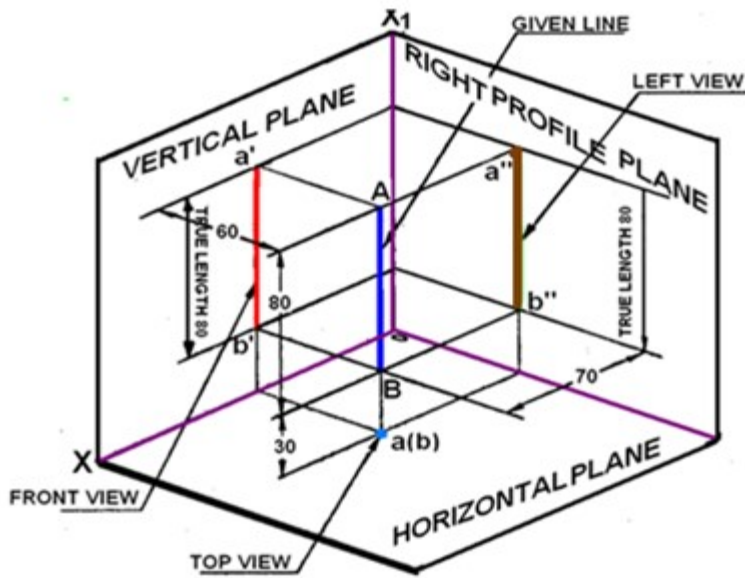

(a)

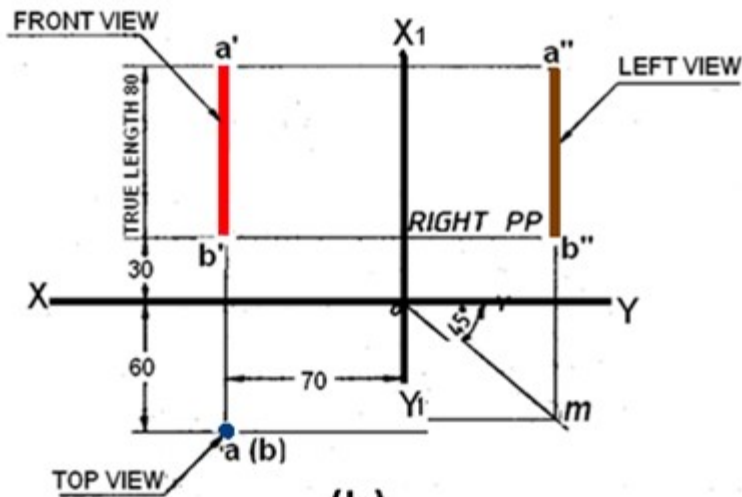

(b)

Figure 4. Projections of a line AB perpendicular to HP and parallel to VP.

### Line parallel to one plane and inclined to the other

#### Case 5. Line parallel to VP and inclined to HP

A line AB, 90 mm long is inclined at  $30^\circ$  to HP and parallel to VP. The line is 80 mm in front of VP. The lower end A is 30 mm above HP. The upper end B is 50 mm in front of the right PP. The projections of line AB shown in figure 5 can be obtained in the following manner. Mark  $a'$ , the front view of the end A, 30 mm above HP. Draw the front view  $a'b' = 90$  mm inclined at  $30^\circ$  to XY line.

Project the top view  $ab$  parallel to XY line. The top view is 80 mm in front of VP. Draw the  $X_1Y_1$  line at a distance of 50 mm from  $b'$ . Draw a  $45^\circ$  line through  $O$ . Draw the horizontal

projector through the top view **ab** to cut the 45° line at **m**. Draw a vertical projector through **m**. Draw the horizontal projectors through **a'** and **b'** to intersect the vertical projector drawn through **m** at **a''** and **b''**. Connect **a''b''** which is the left side view.

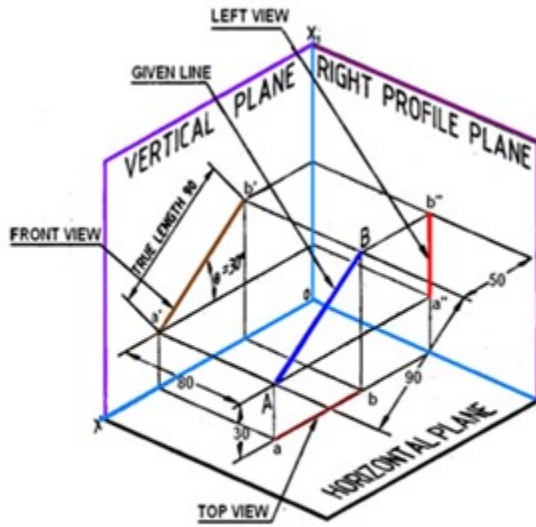

(a)

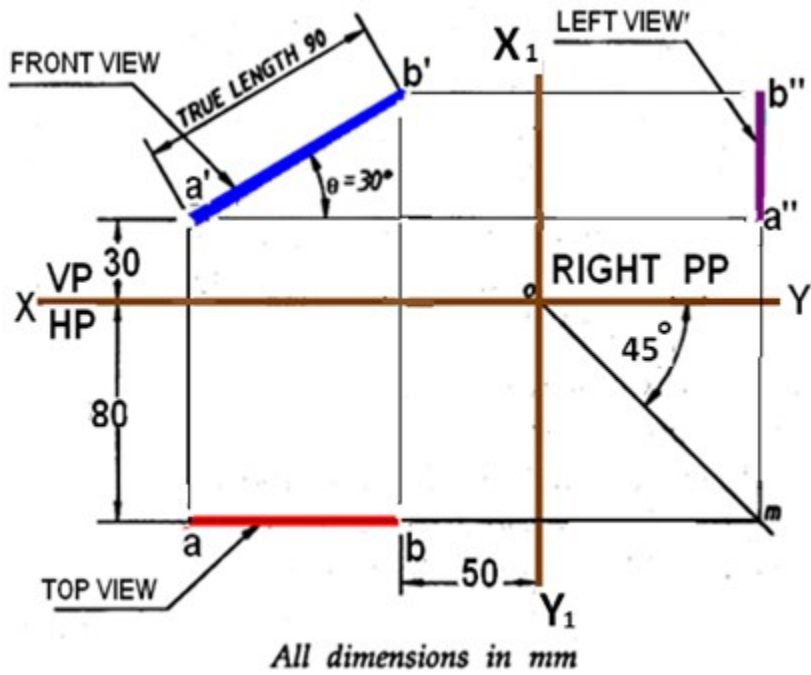

(b)

Figure 5. Projections of line AB parallel to VP and inclined to HP.

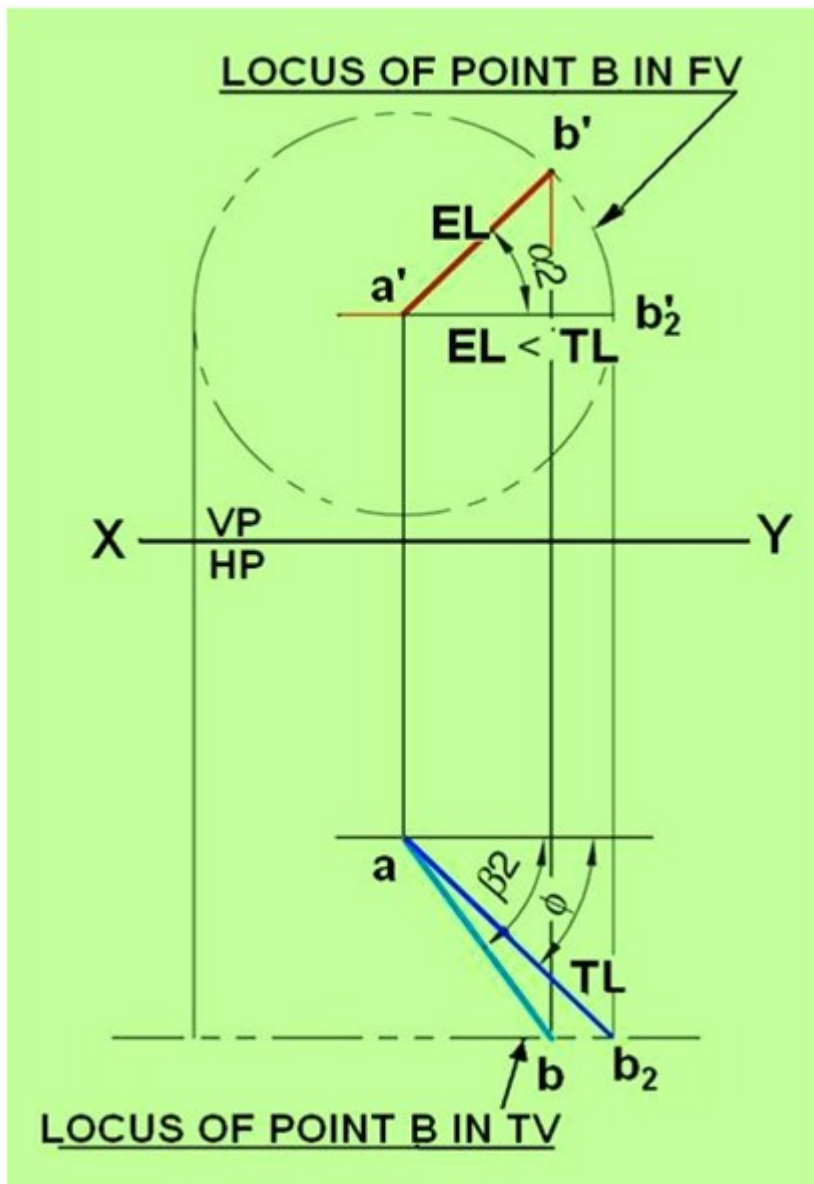

Figure 4. Illustrates the true length and true inclination of the line when it is made parallel to HP.

Figure 5. Illustrates the true length, apparent lengths, true inclination and apparent inclination of the line AB inclined to HP and VP..

## Projections of Planes

### Plane surface (plane/lamina/plate)

A plane is a two-dimensional surface having length and breadth with negligible thickness. They are formed when any three non-collinear points are joined. Planes are bounded by straight/curved lines and may be either regular or irregular. Regular plane surfaces are in which all the sides are equal. Irregular plane surfaces are in which the lengths of the sides are unequal.

### Positioning of a Plane surface

A plane surface may be positioned in space with reference to the three principal planes of projection in any of the following positions:

- Parallel to one of the principal planes and perpendicular to the other two.
- Perpendicular to one of the principal planes and inclined to the other two.
- Inclined to all the three principal planes.

### Projections of a Plane surface

A plane surface when held parallel to a plane of projection, it will be perpendicular to the other two planes of projection. The view of the plane surface projected on the plane of projection to which it will be perpendicular will be a line, called the line view of a plane surface. When the plane surface is held with its surface parallel to one of the planes of projection, the view of the plane surface projected on it will be in true shape because all the sides or the edges of the plane surface will be parallel to the plane of projection on which the plane surface is projected. When a plane surface is inclined to any plane of projection, the view of the plane surface projected on it will be its apparent shape. A few examples of projections of plane surfaces are illustrated below:

#### A: Plane surface parallel to one plane and perpendicular to the other two

Consider A triangular lamina placed in the first quadrant with its surface parallel to VP and perpendicular to both HP and left PP. The lamina and its projections on the three projection planes are shown in figure 1.  $a'b'c'$  is the front view,  $abc$  the top view and  $a''b''c''$  the side view. Since the plane is *parallel to VP*, the front view  $a'b'c'$  shows the true shape of the lamina. Since the lamina is perpendicular to both HP and PP, the top view and side views are seen as lines.

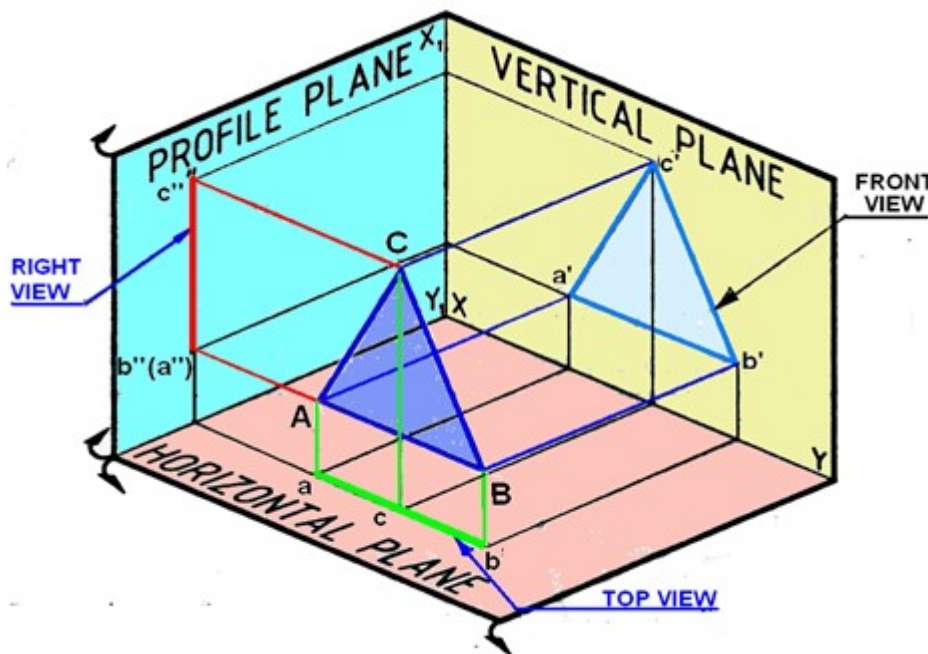

Figure 1. Projections of a triangular lamina on the projection planes

After projecting the triangular lamina on VP, HP and PP, both HP and PP are rotated about XY and  $X_1Y_1$  lines, as shown in figure 2, till they lie in-plane with that of VP

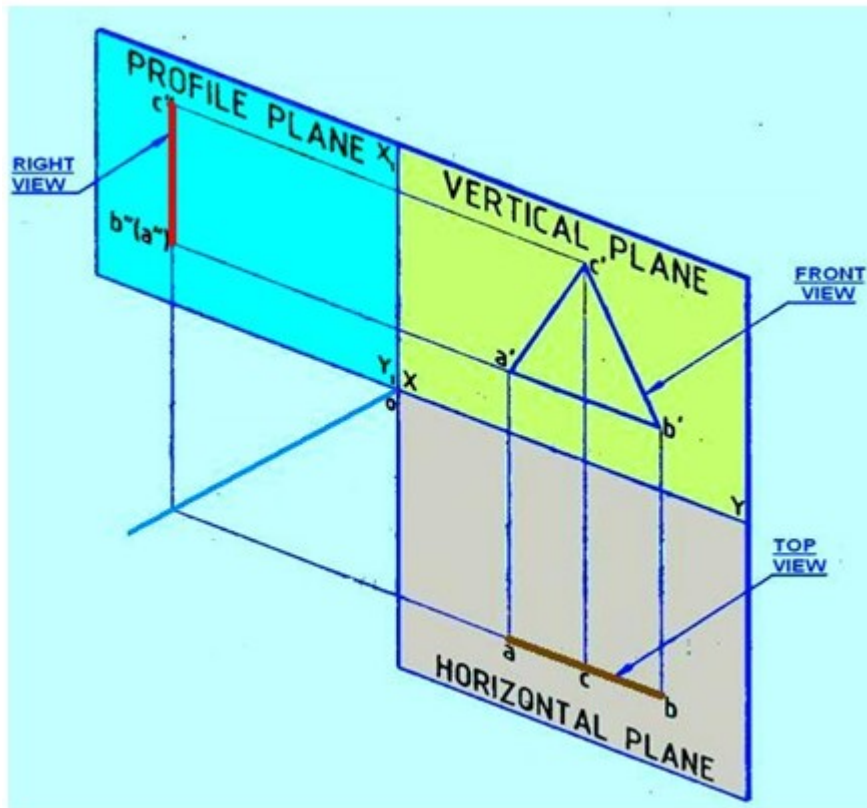

Figure 2. Rotation of PP and HP after projection.

The orthographic projections of the plane, shown in figure 3 can be obtained by the following steps.

Draw  $XY$  and  $X_1Y_1$  lines and mark  $HP$ ,  $VP$  and left  $PP$ . Draw the triangle  $a'b'c'$  in true shape to represent the front view at any convenient distance above the  $XY$  line. In the top view the triangular lamina appears as a line parallel to the  $XY$  line. Obtain the top view  $acb$  as a line by projecting from the front view at any convenient distance below the  $XY$  line.

Since the triangular lamina is also perpendicular to left  $PP$ , the right view will be a *line* parallel to the  $X_1Y_1$  line. To project the right view, draw a  $45^\circ$  line at the point of intersection of the  $XY$  and  $X_1Y_1$  lines. Draw the horizontal projector through the corner  $a$  in the top view to cut the  $45^\circ$  line at  $m$ . Through  $m$  draw a vertical projector. From the corners  $c'$  and  $a'$  in the front view draw the horizontal projectors to cut the vertical projector drawn through  $m$  at  $c''$  and  $b''$ . In the right view the corner  $A$  coincides with  $B$  and hence is invisible.

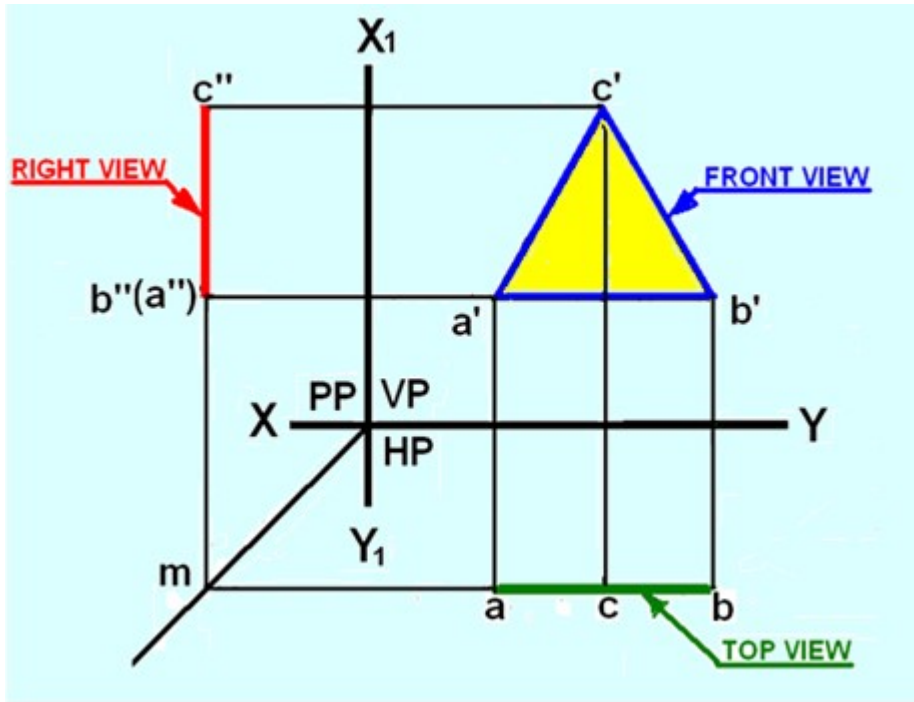

Figure 3. Orthographic projections of the lamina ABC

**B) Plane parallel to HP and perpendicular to both VP and PP**

A square lamina (plane surface) is placed in the first quadrant with its surface parallel to HP and perpendicular to both VP and left PP. Figure 4 (a) shows the views of the object when projected on to the three planes. Top view is shown as  $abcd$ , the front view as  $a'(d')b'(c')$  and the side view as  $b''(a'')c''(d'')$ . Since the plane is parallel to the HP, its top view  $abcd$  will be in its true shape. Since the plane is perpendicular to VP and PP, its front and side views will be lines  $a'(d')b'(c')$  and  $b''(a'')c''(d'')$  respectively. After projecting the square lamina on VP, HP and PP, both HP and PP are rotated about  $XY$  and  $X_1Y_1$  lines, as shown in figure 4(b), till they lie in-plane with that of VP.

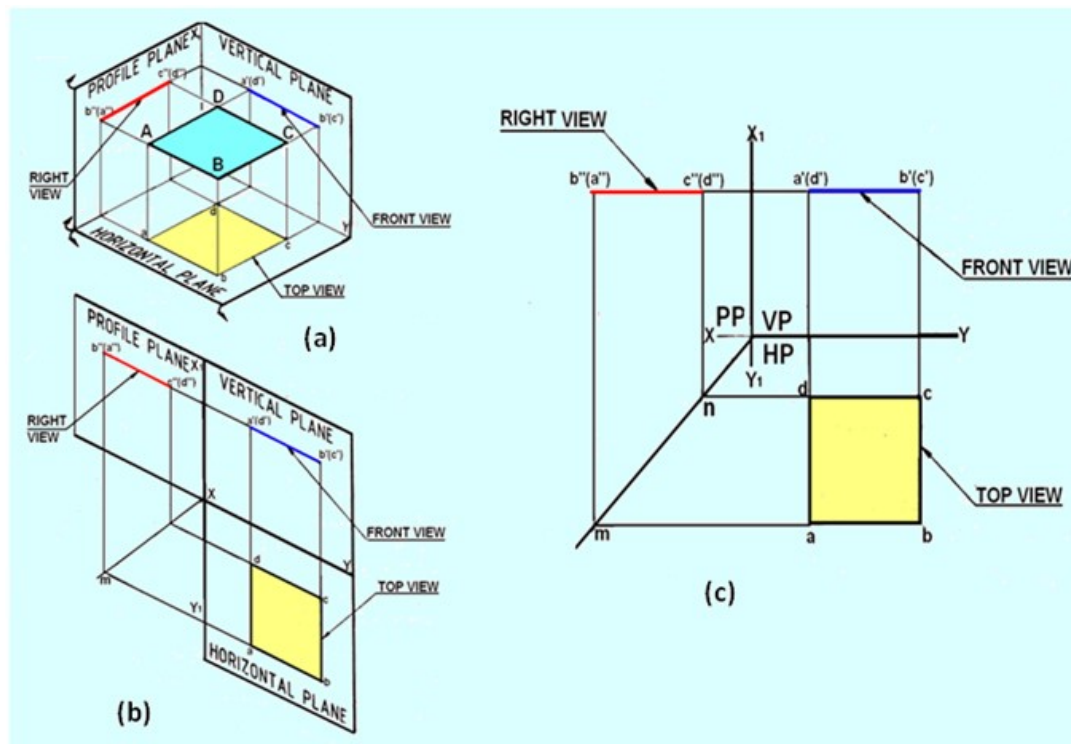

Figure 4. Projections of the lamina with its surface parallel to HO and perpendicular to both VP and PP.

The orthographic projections of the plane, shown in figure 4(c) can be obtained by the following steps.

Draw  $XY$  and  $X_1Y_1$  lines and mark HP, VP and left PP.

Draw the square  $abcd$  in true shape to represent the top view at any convenient distance below the  $XY$  line. In the front view, the square lamina appears as a line parallel to the  $XY$  line.

Obtain the front view as a line  $a'(d')b'(c')$  by projecting from the top view, parallel to the  $XY$  line at any convenient distance above it. In the front view, the rear corners D and C coincide with the front corners A and B, hence  $d'$  and  $c'$  are indicated within brackets.

Since the square lamina is also perpendicular to left PP, the right view projected on it will also be a line perpendicular to  $X_1Y_1$  line. Project the right view as explained in the previous case. In right view, the corners A and D coincide with the corners B and C respectively, hence  $(a')$  and  $(d')$ , are indicated within brackets.

### C) Plane parallel to PP and perpendicular to both HP and VP

A pentagon lamina (plane surface) is placed in the first quadrant with its surface parallel to left PP and perpendicular to both VP and HP.

Figure 5 (a) shows the views of the object when projected on to the three planes. Side view is shown as  $a''b''c''d''e''$ , the front view as  $b'(c')a'(d')e'$  and the top view as  $a(b)e(c)d$ . Since the plane is parallel to the PP, its side view  $a''b''c''d''e''$  will be in its true shape. Since the plane is perpendicular to VP and HP, its front and side views will be projected as lines.

After projecting the pentagon lamina on VP, HP and PP, both HP and PP are rotated about  $XY$  and  $X_1Y_1$  lines, as shown in figure 5(b), till they lie in-plane with that of VP.

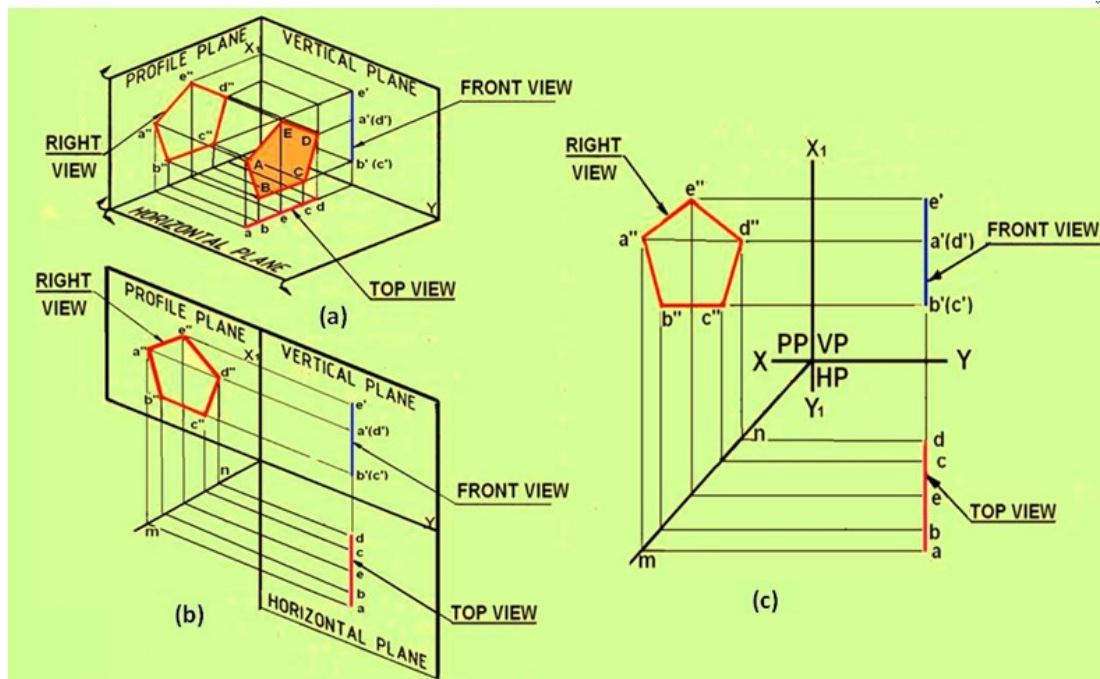

Figure 5 Projections of a pentagonal lamina with its surface parallel to PP and perpendicular to HP and VP.

The orthographic projections of the plane, shown in figure 5(c) can be obtained by the following steps. Draw  $XY$  and  $X_1Y_1$  lines, and mark  $HP$ ,  $VP$  and left  $PP$ . Draw the pentagon  $a''b''c''d''e''$  in true shape to represent the side view at any convenient distance above the  $XY$  line and left of  $X_1Y_1$  line. The top and front views of the lamina appear as lines perpendicular to  $XY$  line. Obtain the front view  $b'(c')a'(d')e'$  as a line by projecting from the right view at any convenient distance from the  $X_1Y_1$  line. In the front view, the rear corners  $D$  and  $C$  coincide with  $A$  and  $B$  respectively, hence  $d'$  and  $c'$  are indicated within brackets. The orthographic projections of the plane, shown in figure 4(c) can be obtained by the following step. Since the pentagon lamina is also perpendicular to  $HP$ , the top view also appears as a line. Project the top view from the right and front views.

#### D) Plane surface perpendicular to one plane and inclined to the other two

1. Plane inclined at  $\Phi$  to  $VP$  and perpendicular to  $HP$  Draw the projections of a triangular lamina (plane surface) placed in the first quadrant with its surface is inclined at  $\phi$  to  $VP$  and perpendicular to the  $HP$ . Since the lamina is inclined to  $VP$ , it is also inclined to left  $PP$  at  $(90 - \Phi)$ . The triangular lamina  $ABC$  is projected onto  $VP$ ,  $HP$  and left  $PP$ .  $a'b'c'$  – is the front view projected on  $VP$ .  $a''b''c''$  – is the right view projected on left  $PP$ . Since lamina is inclined to  $VP$  and  $PP$ , front and side views are not in true shape. Since lamina is perpendicular to  $HP$ , its top view is projected as a line  $acb$  Figure 6 (c) shows the multiview drawing of the lamina.

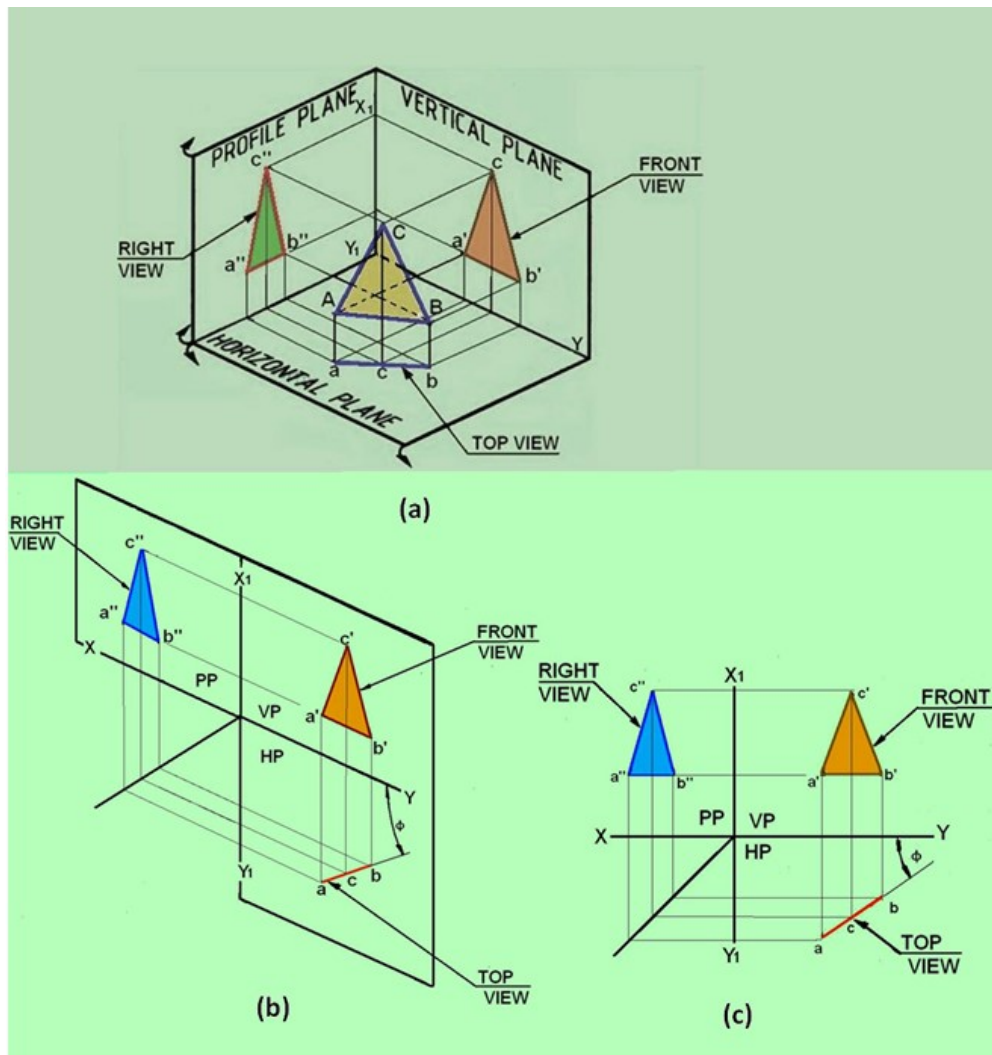

Figure 6. The projections of the triangular lamina

**Problem 1:** A regular pentagonal lamina of 30 mm side rests on HP with its plane surface vertical and inclined at  $30^\circ$  to VP. Draw its top and front views when one of its sides is perpendicular to HP.

**Solution:** The projections The pentagonal lamina has its surface vertical (i.e., perpendicular to HP) and inclined at  $30^\circ$  to VP. Since the lamina is inclined to VP, initially it is assumed to be parallel to VP. In this position one of the sides of the pentagon should be perpendicular to HP. Therefore, draw a regular pentagon  $a'b'c'd'e'$  in the VP to represent the front view with its side  $a'e'$  perpendicular to HP. Since the lamina is perpendicular to HP, the top view will be a line,  $a(e)b(d)c$ . Assume that edge  $a'e'$  perpendicular to HP in the final position. The top view of the lamina is now rotated about  $a(e)$  such that the line is inclined at  $30^\circ$  to XY line, as shown by points  $a_1, b_1, c_1, d_1,$  and  $e_1$  in the right bottom of Figure 1. Draw vertical projectors from points  $a_1, b_1, c_1, d_1,$  and  $e_1$ . Draw horizontal projectors from points  $a', b', c', d',$  and  $e'$ . The intersection gives the respective positions of the points in the Front view. Join  $a_1', b_1', c_1', d_1',$  and  $e_1'$  to obtain the Front view of the lamina.

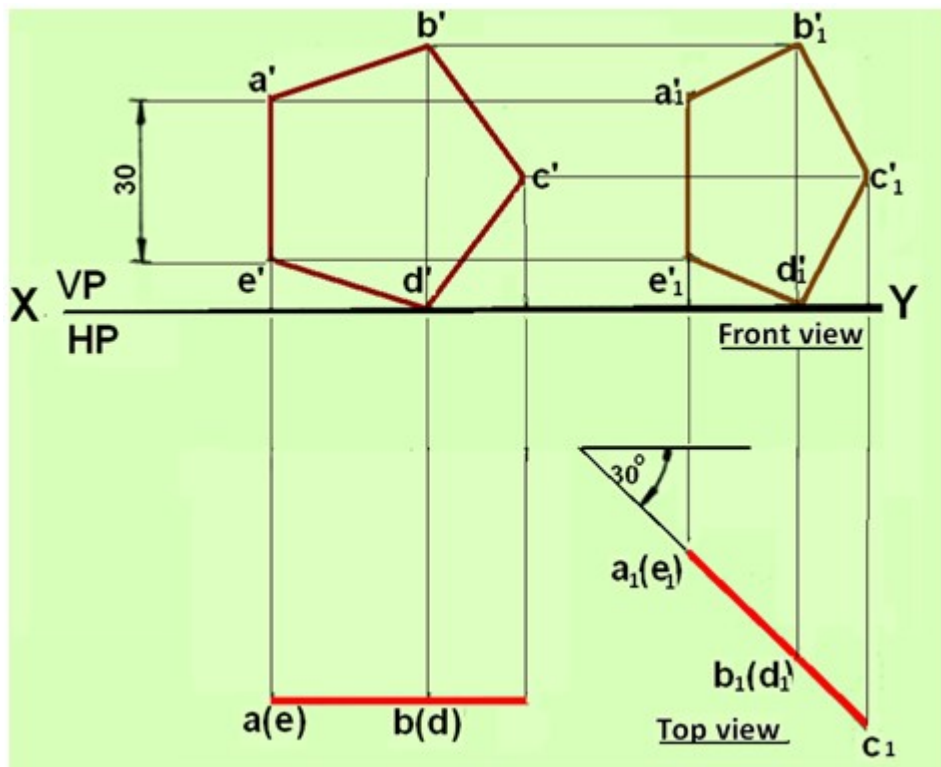

Figure 1. Orthographic projections of the pentagonal lamina.

**Problem 2.** Draw the front view, top view and side view of a square lamina. The surface of the lamina is inclined at  $\theta$  to HP and perpendicular to VP.

**Solution.** The three views of the square lamina is shown in figure 2. Since the lamina is perpendicular to VP, its front view will be a line  $[a'(b') c' (d')]$  having length as the true length of the edge of the square and inclined at  $\theta$  to XY line. The corners B and C coincide with A and D in the front view. Since the lamina is inclined to HP at  $\theta$ , it is also inclined to the left PP at  $(90 - \theta)$ . The square lamina is projected on to VP, HP and left PP. Draw vertical projectors from points  $a', b', c'$  and  $d'$ . On any position on these lines construct the rectangle  $a-b-c-d$  such that length  $ab$  and  $cd$  are equal to the true length of the square edge. The rectangle  $a-b-c-d$  is the top view of the lamina. The side view of the lamina  $a'', b'', c''$  and  $d''$  can be obtained by drawing projectors from points  $a', b', c'$  and  $d'$  and  $a, b, c,$  and  $d$ .

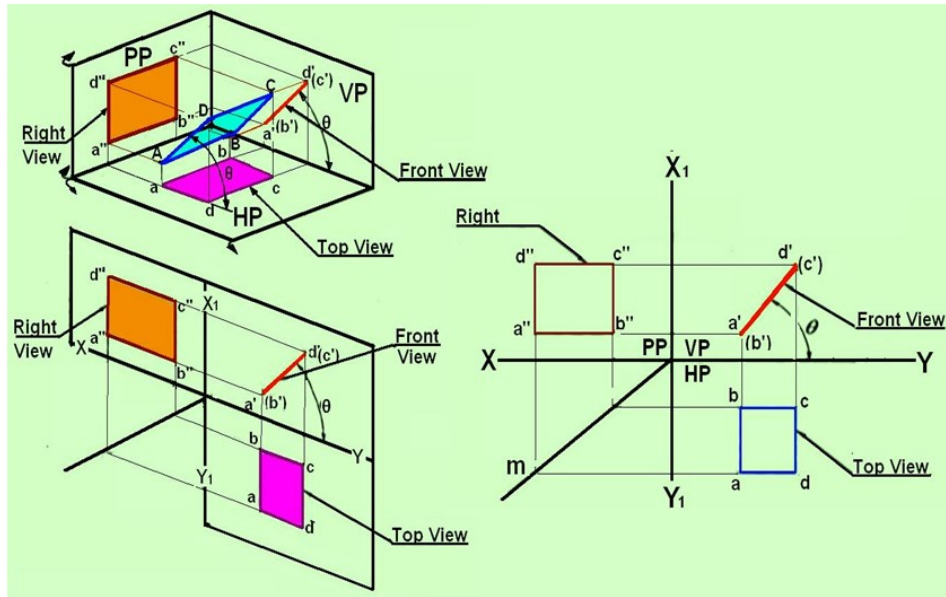

Figure 2. The projection of the square lamina as mentioned in problem 2.

**Problem 3.** Draw the Top view and front view of a circular lamina if the surface of the lamina is perpendicular to HP and inclined at  $30^\circ$  to VP.

**Solution:** The projections of the circular lamina is shown in figure 3. Let us first assume that the plane is perpendicular to HP and parallel to VP. The Front view will be a circle and with diameter equal to the diameter of the lamina. Divide the circle into 12 equal parts and label them as  $1', 2', 3', \dots, 12'$ . The top view will be a straight line  $1-7$ , parallel to XY line and can be obtained by drawing projectors from  $1', 2', \dots, 12'$ . Since the circle is inclined at  $30^\circ$  to VP and perpendicular to HP, reconstruct the top view such that the straight line is inclined at  $30^\circ$  to XY line. Let the respective points be  $11, 21, 31, \dots, 121$ . Draw vertical projectors from points  $11, 21, 31, \dots, 121$  to meet the horizontal projectors from points  $1', 2', 3', \dots, 12'$  to obtain the points  $11', 21', 31', \dots, 121'$  in the Front view. Draw a smooth curve passing through points  $11', 21', 31', \dots, 121'$  to obtain the Front view of the circular lamina.

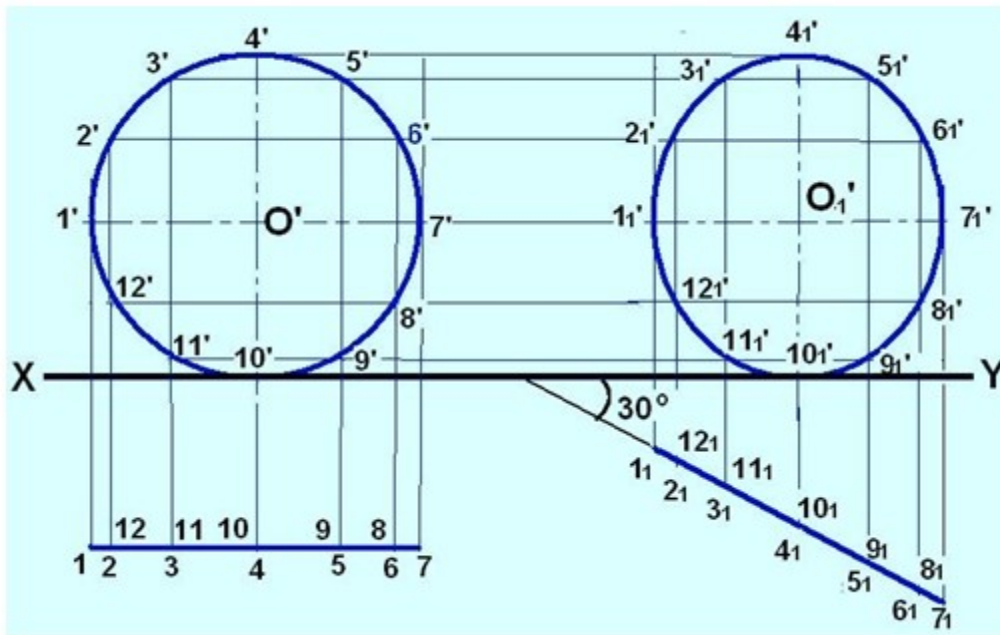

Figure 3. Projections of the circular lamina mentioned in problem 3.

### SECTIONAL VIEWS

The view obtained on a piece of paper after cutting the object by means of cutting plane is known as sectional view. The sectional view is drawn after removing the nearer portion of the object which enables the observer to know its internal details.

Fig. 1 the position of sectional plane on the pictorial view of the object.

Fig. 2 shows the pictorial view of the sectioned object after removing the nearer portion of the object at the centre.

Fig. 3 shows the full sectional front view of the same object.

### TYPES OF SECTIONAL VIEWS

The following are the types of sectional views which are commonly used in engineering practice

- (i) Full sectional view.
- (ii) Half sectional view.

Full Sectional View: The sectional view obtained after removing the front half

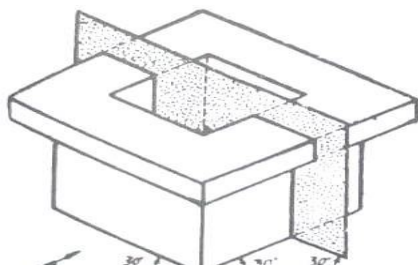

Fig. 1

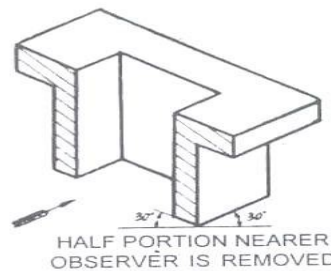
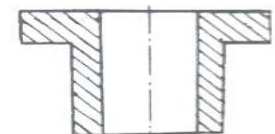

Fig. 2



SECTIONAL FRONT VIEW  
Fig. 9.3

Fig. 3

## SECTIONAL VIEW OF A SIMPLE OBJECT

Portion of the object through its centre is known as full sectional view or front sectional elevation or simply sectional elevation.

Fig. 4 shows the sectional front view of a typical object.

Caution: These two views have been added to enable the students to follow the sectional views thoroughly.

Important Notes: The full sectional view if seen from the side after removing half portion of the object from side is known as full sectional side view.

The following points should be observed while making a full sectional view :

- (i) Invisible lines behind the sectional plane should be omitted.
- (ii) Visible lines behind the sectional plane should be shown.
- (iii) Only the parts actually sectioned or cut should be hatched.
- (iv) The position of sectional plane or cutting plane should be shown on final drawing.

Half Sectional View: The sectional view obtained after removing front quarter portion (ie.  $\frac{1}{4}$ ) by means of two cutting planes at right angles to each other is known as half sectional view or simply half sectional elevation.

Fig. 5 shows the position of cutting or sectional plane on the pictorial view of an object.

Fig. 6 shows the pictorial of the sectioned object removing the nearer portion of the object.

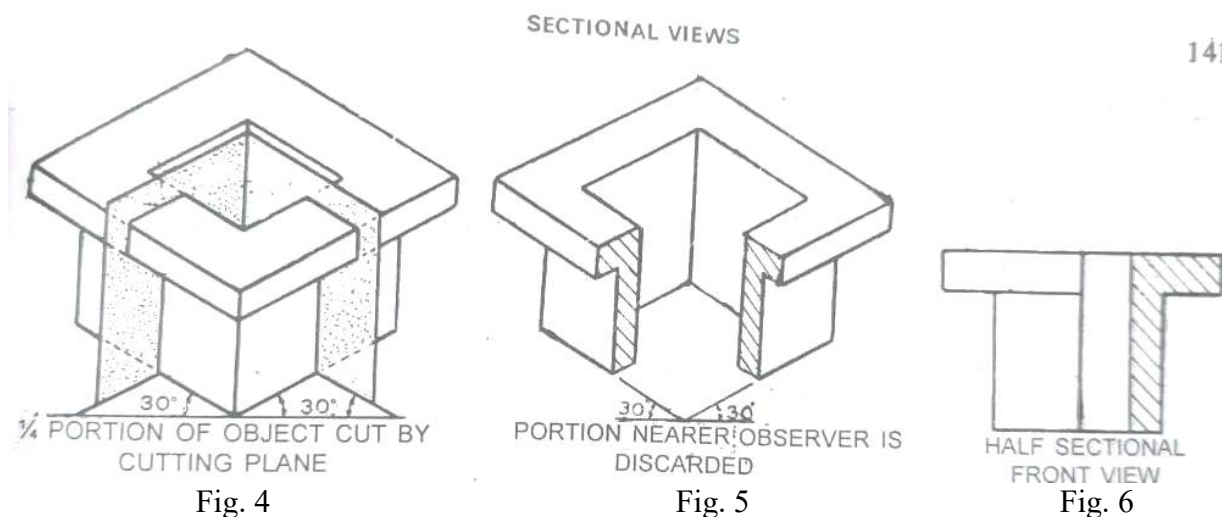

### 9.4 IMPORTANT CONVENTIONS TO REMEMBER

The following conventions should be remembered while doing the problems on sectioning

The nuts, bolts, rivets, shafts, rods, balls, rollers, keys, cutters, arrows, pint ribt, spokes, arms, handles, wings and other thin solid parts should never be sectioned when their axes are parallel to the plane of paper. However, cross-section of broken cut sections can be used wherever required.

- (1) The centre lines are used to separate two halves of a sectional view.
- (i) All hidden lines of the sectioned object should be omitted.

9.5. SECTIONAL PLANE OR CUTTING PLANE An imaginary plane which is used to cut the object in order to know its internal detail is known as sectional plane or cutting plane. The sectional plane or cutting plane is shown by means of a line known as cutting plane line.

#### CUTTING PLANE LINE

The cutting plane line consists of thick line attached with arrowhead on either sides but like a centre line as shown in fig. 7

Caution: The students are advised to note the cutting plane carefully as this line has been changed by the latest ISI No. 6:6-1972. In addition to this, no correct methods of making the arrowheads have been given. The students can use any one of them.

#### 9.6. SECTION LINING

The section lines are drawn in the section face, the portion which is cut by a sectional plane.

The following principles should be followed while drawing section lines: (1) The section lines are drawn at an angle of 45 to the horizontal or outline or main or axis of the section.

#### CORRECT AND INCORRECT SECTION LININGS

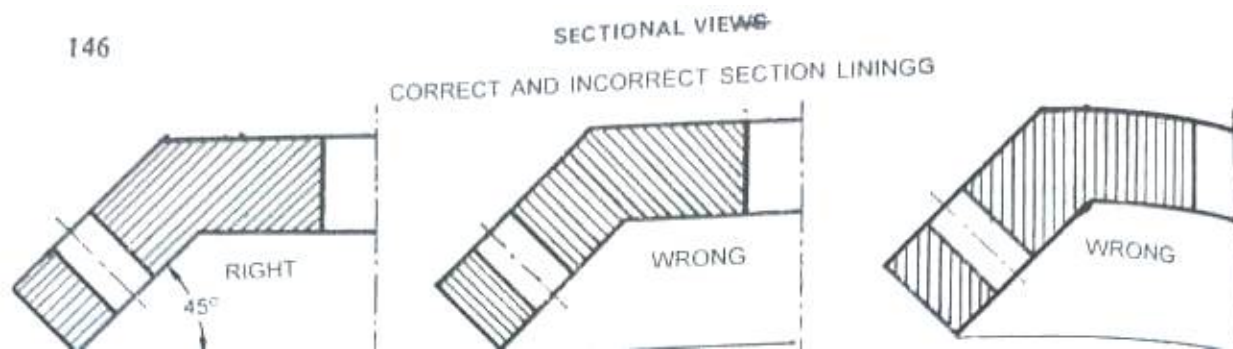

Fig. 7

Fig. 7 shows the correct; and incorrect method of sectioning the object. (3) The spacing between the section lines should be chosen in proportion to the size of the hatched area. These line should be spaced uniformly and spacing of about 3 mm. However in large drawings, the distance can be taken upto 4 mm.

#### COMMON ERRORS IN SECTION LINING

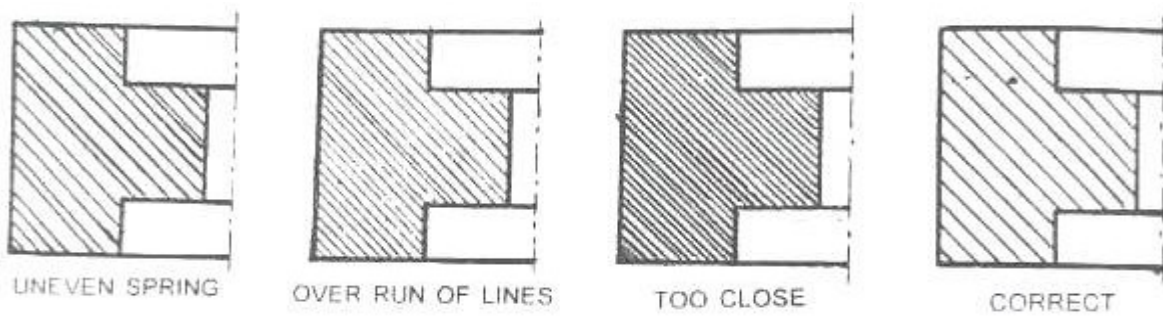

Fig. 8

Fig. 8 shows the common errors in sectioning the object.

(3) The hatching of two adjacent parts should be done as shown in fig. 9.

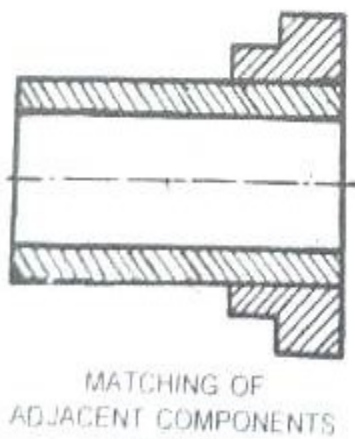

Fig. 9

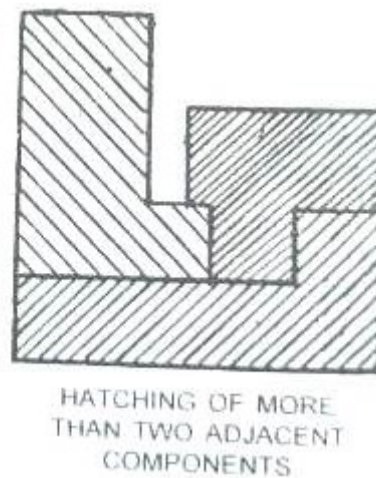

Fig. 10

(4) In case of more than two adjacent parts, hatching should be done as shown in fig. 10

In this, stress has been made to differentiate the object by drawing section lines in different directions and of varying distance between the hatching lines.

(v) In case of large area, section lines should be limited to a small portion as shown in fig. 9-20.

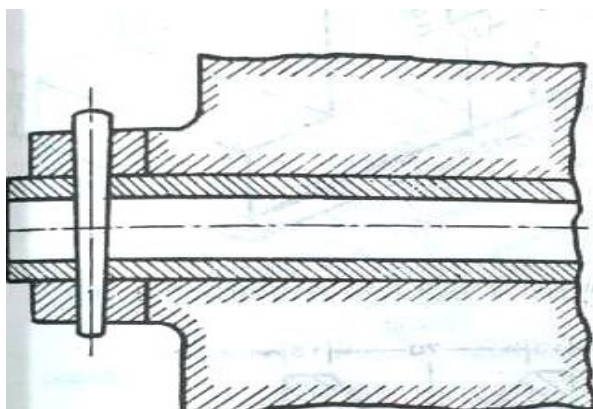

Fig. 11

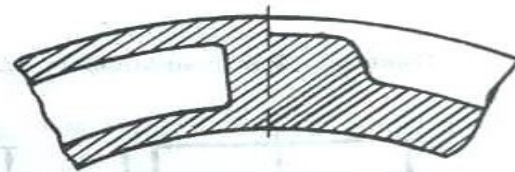

Fig.12

(vi) In case of adjacent sections of the same parts in different planes, section lines may be drawn as shown in fig. 12.

(vii) When it is not possible to give the dimension outside the object, then section lines should be interrupted for giving dimensions as shown in fig. 13

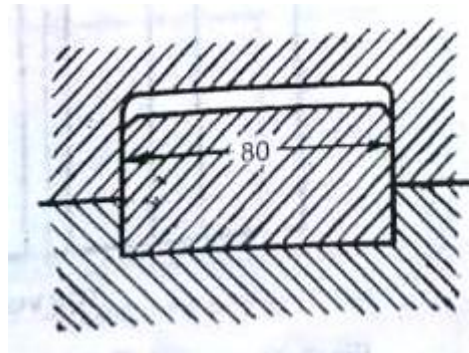

Fig. 13

Example 1. Fig. 14 shows the pictorial view of a V-BLOCK. Draw to full size scale (1:1), the

Following views:

- (1) Elevation, fully in section or Sectional elevation.
- (ii) Top view or Top plan.
- (ii) Right sectional end view.

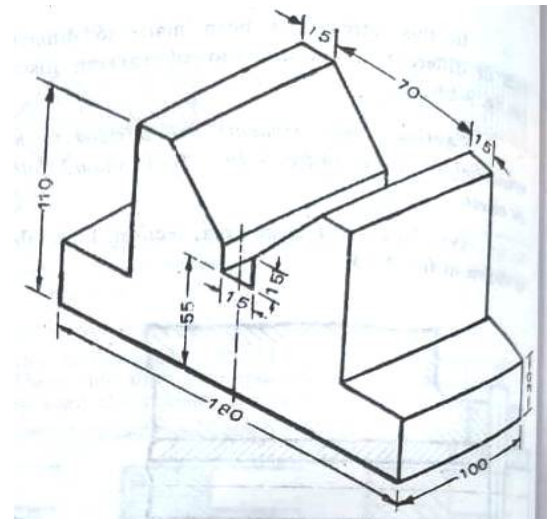

Fig. 14

Solution: For its solution, see fig. 15 which is itself a self-explanatory

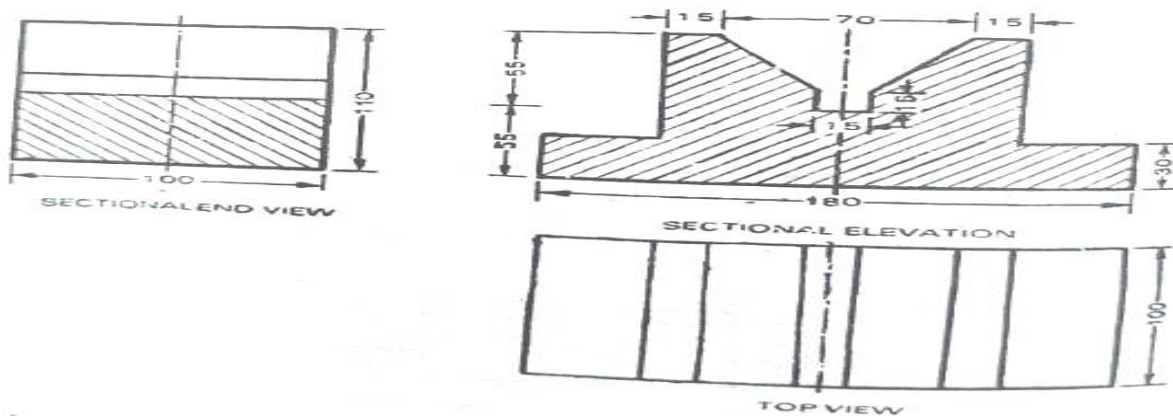

Fig. 15

Example 2 Fig. 16 shows the pictorial view of a SIMPLE BEARING. Draw to a suitable scale the following views

- (i) Full sectional elevation.
- (ii) Top plan
- (iii) Left sectional end view

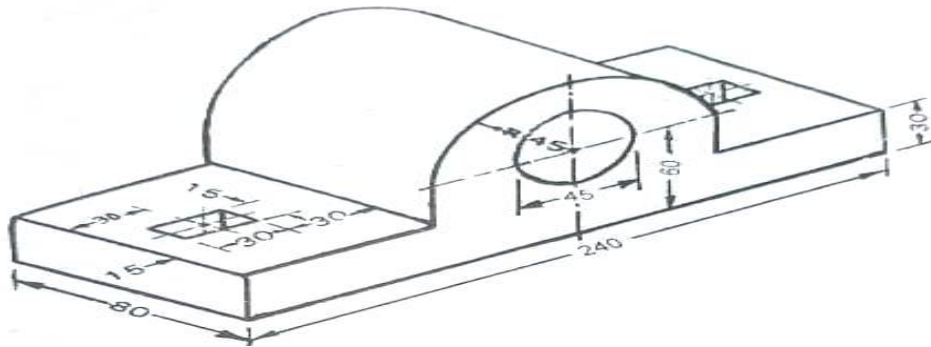

Fig. 16

Solution: For its solution, see fig. 17 which is itself a self-explanatory sketch

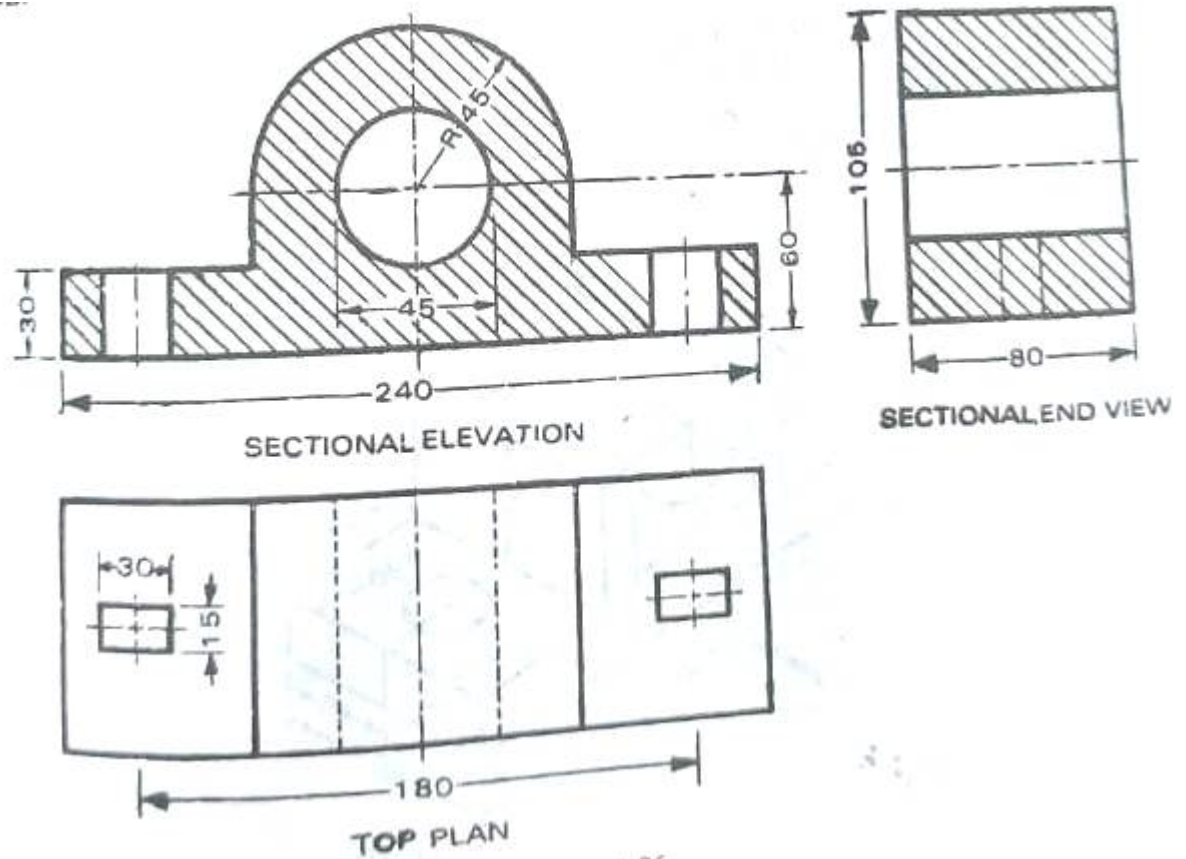

Fig. 17

## EXCERCISE

### A. MULTIPLE CHOICE QUESTIONS:

1. In first angle projection, object is assumed to be situated in
  - (a) first quadrant.
  - (b) second quadrant.
  - (c) third quadrant.
  - (d) fourth quadrant.
2. In first angle projection, top view is placed
  - (a) above front view.
  - (b) below front view.
  - (c) Any of (a) and (b).
  - (d) None of the above.
3. First angle projection is commonly used in
  - (a) India.
  - (b) U.S.A.
  - (c) Australia.
  - (d) Both (b) and (c).
4. In first angle projection, view from top is placed on the..... of front view.
  - (a) top
  - (b) below
  - (c) right
  - (d) left
5. In which projection, L.H.S. view is placed on L.H.S.?
  - (a) First angle projection
  - (b) Second angle projection
  - (c) Third angle projection
  - (d) Fourth angle projection
6. In first angle projection, front view is projected on
  - (a) H.P.
  - (b) V.P.
  - (c) P.P.
  - (d) A.V.P.
7. While selecting the side view in three view drawing, take ..... side for third angle projection and..... side for first angle projection as far as possible.
  - (a) right, left
  - (b) left, right
  - (c) right, right
  - (d) left, left
8. The layout of its first angle projection is Top view
  - (a) Right side view Front view Left side view
  - (b) Right side view- Front view-Right side view
  - (c) Right side view- Front view-Left side view
  - (d) Left side view Front view Left side view
9. In first angle projection, object is placed
  - (a) above H.P. and in front of VP
  - (b) above H.P. and behind V.P.

- (c) below H.P. and in front of V.P.  
 (d) below HP. and behind V.P
10. In first angle projection, bottom view is placed  
 (a) above front view.  
 (b) below top view.  
 (c) above top view.  
 (d) below front view.
11. In third angle projection, plane of projection comes between the .....and....  
 (a) object and observer. (b) Observer and object (c) Any of (a) and (b) (d) None of the above.
12. In third angle pr...  
 (a) Left side view (b) bottom view (c) Right side view (d) Top view
13. In third angle projection, to obtain left side view, a V.P. is assumed to be placed on  
 (a) right side of the object. (b) left side of the object. (c) top of the object. (d) None of the above.
14. In third angle projection, top view is  
 (a) above XY line. (b) below XY line. (c) Any of (a) and (b). (d) None of the above.
15. In third angle projection, front view is projected on  
 (a) H.P. (b) A.V.P. (c) P.P. (d) V.P.
16. In which projection, projectors are perpendicular to the plane of projection and parallel to each other?  
 (a) Oblique projection  
 (b) Orthographic projection  
 (c) Perspective projection  
 (d) None of the above.
17. In third angle projection, the side view is projected on  
 (a) V.P (b) H.P. (c) P.P. (d) None of the above.
18. In which projection, projectors are parallel to each other, but inclined at an angle of  $30^\circ$  to the plane of projection ?  
 (a) Oblique projection  
 (b) Axonometric projection  
 (c) Perspective projection  
 (d) None of the above.
19. The projections of an object in an orthographic projection are taken on planes, while they are shown on a plane sheet of paper by placing them at their defined place.  
 (a) parallel  
 (b) mutually perpendicular  
 (c) mutually inclined  
 (d) All of the above.
20. When two hidden lines are intersecting, their dashes should..... at the point of intersection.  
 (a) not touch (b) touch (c) Inclined (d) None of the above.
21. In third angle projection view from left is placed on the ..... of front view.  
 (a) top (b) bottom (c) right (d) left
22. In which projection, R.H.S. view is placed on L.H.S.?  
 (a) First angle projection  
 (b) Second angle projection  
 (c) Third angle projection  
 (d) Fourth angle projection

23. In third angle projection, the L.H.S. view is
- (a) above XY line.
  - (b) below XY line.
  - (d) None of the above.
  - (c) Any of (a) and (b).
24. Choose the correct statement for third angle projection
- (a) In this method, front view or elevation lies below XY line, top view or plan above the XY line and L.H.S. view is drawn to the L.H.S. of front elevation.
  - (b) In this method, both front view and top view lie above XY line
  - (c) In this method, front view lies below XY line, top view below XY line and L.H.S. view is drawn on R.H.S. of front view
  - (d) None of the above
25. In third angle projection,
- (a) object lies between observer and plane of projection.
  - (b) plane of projection lies between observer and object.
  - (c) observer lies between object and plane of projection.
  - (d) Any of the above.
26. In third angle projection, left side view is placed
- (a) on left of top view.
  - (b) on right of front view.
  - (c) on left of front view.
  - (d) on right of top view.
26. In third angle projection, view from above is known as
- (a) front view.
  - (b) elevation.
  - (c) plan.
  - (d) side view.
27. Side view of an object contains..... of the object
- (a) length and height dimensions.
  - (b) length and breadth dimensions
  - (c) breadth and height dimensions.
  - (d) length, breadth and height dimensions
28. Second and fourth angle projections are usually not followed because
- (a) both are not possible to draw.
  - (b) both front view and top view overlap.
  - (c) it gives large number of lines which are difficult to interpret.
  - (d) Both (b) and (c).
29. In first angle projection, object lies
- (a) below H.P.
  - (b) behind the observer.
  - (c) in between the plane of projection and observer.
  - (d) Behind V.P
30. In third angle projection, lies between observer and object.
- (a) plane of projection.
  - (b) orthographic projection.
  - (c) Both (a) and (b).

(d) None of the above.

31. To show front view and top view on drawing sheet, generally H.P is rotated at angle of

(a)  $45^\circ$                       (b)  $30^\circ$                       (c)  $60^\circ$                       (d)  $90^\circ$

32. Which plane of projection is movable ?

(a) H.P

(b) V.P.

(c) P.P.

(d) Oblique plane

33. Which view is obtained when point is situated between ray of sight and H.P. ?

(a) Top view

(b) Side view

(c) Front view

(d) Any of the above

34. A surface of an object appears in its true shape when it is

(a) placed parallel to plane of projection.

(b) perpendicular to plane of projection.

(c) inclined to plane of projection.

(d) None of the above

#### Answers

1.(a)	2.(b)	3.(a)	4.(b)	5.(c)
6.(b)	7.(a)	8.(c)	9.(a)	10.(a)
11.(c)	12.(c)	13.(b)	14.(a)	15.(d)
16.(b)	17.(c)	18.(b)	19.(b)	20.(b)
21.(d)	22.(a)	23.(b)	24.(a)	25.(b)
26.(c)	27.(c)	28.(c)	29.(d)	30.(c)
31.(a)	32.(d)	33.(a)	34.(a)	35.(a)

#### B. Short Answer Question

1. Define Projection

2. Name various types of projections

3. Define pictorial projection.

4. Define perspective projection.

5. Define isometric projection.

6. Define oblique projection.

7. Define orthographic projection.

8. Define plane of projection.

9. Define ground line.

10. Define (i) Horizontal plane, (ii) Vertical plane.

11. What is auxiliary plane?

12. Define profile plane.

13. Define :

(i) Front view, (ii) Top view, (iii) Side view.

14. Draw the symbol of first angle projection.

15. Draw the symbol of third angle projection.