3RD SEM

CIVIL ENGINEERING

FLUID MECHANICS

SUBJECT CODE

(220735)

BY – AMIT KUMAR

Index

Chapter No.	Contents	Page No.
1	Introduction	1
	1.1 Real Fluids	1
	1.2 Ideal Fluids	1
	1.3 Hydraulics	1
	1.4 Hydrodynamics	1
	1.5 Hydrostatics	1
	Theoretical Questions	2
2	Properties of fluids	3
	2.1 Density or Mass Density	3
	2.2 Weight Density or Specific Density	3
	2.3 Specific Volume	4
	2.4 Specific Gravity	4
	2.5 Surface Tension	5
	2.6 Cohesion, Adhesion, Surface Tension & Capillarity	5
	2.7 Compressibility	5
	2.8 Characteristics of Vapour Pressure	6
	2.9 Viscosity	6
	Exercises - Multiple choice questions	10
	- Short answer type questions	11
3	Hydraulic Pressure	12
	3.1 Hydraulic Pressure	12
	3.2 Pascal's Law Derivation	13
	3.3 Total Pressure and Centre of Pressure	14
	Numerical Problems	25
4	Measurement of Pressure	27
	4.1 Introduction	27
	4.2 Pressure	27
	4.3 Measurement of Pressure	30
	4.4 Simple Manometers	31
	4.5 Differential Manometers	39
	4.6 Manometric Liquids	45
	4.7 Mechanical Gauges	45
	Theoretical Questions	47
5	Fundamentals of Fluid Flow	51
	5.1 Introduction	51
	5.2 Types of Flow	51
	5.3 Rate of Flow or Discharge	52
	5.4 Continuity Equation	52
	5.5 Types of Hydraulic Energies	53
	5.6 Bernoulli's Theorem	54
	Solved Problems	55

	Important Questions for Practice	60
6	Venturimeter	61
	6.1 Venturimeter	61
	6.2 Orifice Meter (Orifice Plate)	66
	6.3 Pitot Tube	68
	6.4 Pitot-Static Tube	69
	6.5 Orifice	70
	6.6 Classification of Orifices	70
	6.7 Some important technical terms	71
	6.8 Hydraulic Co-efficients (Orifice Co-efficients)	71
	6.9 RELATIONSHIP BETWEEN C_c , C_v and C_d	72
	6.10 Discharge through a rectangular orifice	73
	6.11 Mouthpieces	75
	6.12 Notch	75
	6.13 Weir	76
	6.14 Difference between notches and weirs	77
	6.15 Current Meter	78
7	Flow Through Pipes	81
	7.1 Definition	81
	7.2 Laminar and Turbulent Flow	81
	7.3 Reynold's Number	82
	7.4 Laminar and Turbulent Flow explained through Reynold's Number	83
	7.5 Critical velocity and velocity distributions in a pipe for Laminar Critical Velocity	86
	7.6 Loss of Energy (or Head) in Pipes	88
	7.7 Hydraulic Gradient and Total Energy Line	92
	7.8 Flow from one reservoir to another a long pipe of uniform cross - section (simple problems)	95
	7.9 Pipes in Series and Parallel	97
	7.10 Water Hammer Phenomenon and its effects	100
	Exercises	101
8	Flow Through Open Channel	103
	8.1 Introduction to Open Channel	103
	8.2 Comparison of Open Channel Flow and Pipe Flow	103
	8.3 Steady & Unsteady Flow	104
	8.4 Uniform & Non-Uniform Flow	104
	8.5 Uniform Flow -Chezy's Formula	105
	8.6 Conveyance of a Channel Section	109
	8.7 Hydraulic mean depth for some particular channel sections	111
	8.8 Side slopes for a channel	111
	8.9 Most economical section of channel or Channel of best section	111
	8.10 Examples of Flow Through Open channels	115
	Numerical Problems	122
9	Hydraulic Pumps	123
	9.1 Definition	123

	9.2	Types of Reciprocating Pumps	124
	9.3	Working of Single Acting & Double Acting Reciprocating Pump	124

CONFIDENTIAL

Chapter - 1

Introduction

Introduction

Fluid mechanics is the branch of engineering which deals with the mechanics of fluids (in liquids and gaseous state) and the various types of forces acting on them. It has applications in different disciplines of engineering like civil engineering, mechanical engineering, chemical engineering, and biomedical engineering, geophysics, oceanography, meteorology, astrophysics, and biology.

Fluid mechanics broadly divided into two filed 1. **fluid statics**, which deals with the study of fluids at rest; and 2. **fluid dynamics**, deals with the study of the fluid in motion.

Real fluids

Fluids which do posses various properties like viscosity, surface tension, density, specific weight, specific gravity are termed as real fluids. These fluids always offer resistance to the shear forces acting on them. All the fluids in actual practice are real fluids.

Ideal fluids

Ideal fluid is only an imaginary fluid. These are the fluid which is incompressible and is having no viscosity and no surface tension, is known as ideal fluid. These are the imaginary fluid only considered to simplify the problems. Ideal fluid is also known as in viscid fluid or perfect fluid.

Hydraulics

Hydraulics is the branch of the engineering which deals with the study of fluid (mostly water) in flow as well in rest. It deals with the collection, storage, control, flow, regulation, measurement, and use of water.

Hydrodynamics

Hydrodynamics is the branch of the engineering which deals with the study of fluids in motion and the various forces acting on them

Hydrostatics

Hydrostatics is the branch of engineering which deals with the study of the fluid at rest normally with the pressure exerted by the fluid on an immersed body.

Theoretical Questions

- 1. What do you understand by fluid mechanics?**
- 2. Differentiate between ideal and real fluid.**

CHAPTER-2 PROPERTIES OF FLUIDS

Density or Mass Density

The mass density or Density of a fluid is defined as the ratio of a mass of fluid to its volume of the fluid.

ρ (rho) and the unit of mass density is (**kg/m**).

The density of liquid may be constant but the density of gases changes with the variation of temperature and pressure.

(The Density of water is 1000 g/m) or (we can say 1 g/cm).

ρ (rho) = (Mass of Fluid) / (Volume of Fluid)

Weight Density or Specific Weight

Weight density or specific density of a fluid is defined as the ratio of the weight of fluid to its volume of the fluid.

Weight density is called Weight per unit volume of a fluid. This is denoted by symbol ‘ **w** ‘ and the unit of mass density is (**N/m**).

$w = (\text{Weight of Fluid}) / (\text{Volume of fluid})$

$= (\text{Mass of fluid}) * (\text{Acceleration due to gravity}) / (\text{Volume of fluid})$

And we know from the previous formula of Density. So this becomes **$w = \rho * g$**

The value of weight density or specific weight for water is 9.81*1000 N/m

Specific Volume

The specific volume of a fluid is defined as the ratio of the volume of fluid to the mass of fluid.
or

The volume of a fluid occupied by a unit mass or volume per unit mass of a fluid is called Specific volume.

The unit of Specific volume is **m³/kg** and this is commonly applied to Gases.

Specific Volume = (Volume of fluid) / (Mass of fluid)

When we divide by volume of fluid to the Numerator and Denominator the fraction we get is,
= (1) / (ρ)

Specific volume is the reciprocal of Mass Density as seen from the formula we got.

Specific Gravity

This is defined as the ratio of the Density or weight density of a fluid to density or weight density of a standard fluid.

We know the Standard fluid is water so for liquid the water is standard fluid and For gases, the Standard fluid is taken as Air.

Most important the specific gravity is called Relative Density. This is denoted by the symbol 'S' and this is dimensionless because the upper unit and lower units get cancelled.

$$S (\text{liquid}) = (\text{Weight Density of liquid})/(\text{Weight Density of water})$$

Here liquid cannot be the same as water it can be some oil and other.

$$S (\text{Gases}) = (\text{Weight Density of Gases} / (\text{Weight Density of Air}))$$

Now,

$$\text{Weight density of liquid} = S * \text{Weight Density of water}$$

$$= S * 9.81 * 1000 \text{ N/m}$$

$$\text{Density of liquid} = S * \text{Density of water} = S * 1000 \text{ kg/m}$$

Surface Tension

Surface tension is the property of liquid which arises due to the fact that the molecules of the liquid at the surface are in a different situation than those in the interior of the liquid. A molecule lying inside the liquid is surrounded by other molecules and so is attracted equally in all directions. Hence, the net force of attraction acting on the molecule is zero.

A molecule lying on the surface is attracted more by the molecules lying in the bulk of the liquid than by the molecules lying above it in the vapor phase. A molecule lying on the surface experiences a net inward attraction. As a result of this inward pull on all molecules lying on the surface, the surface behaves as if it were under tension.

In other words, the [surface tension](#) of a liquid is defined as the [force](#) acting at right angles to the surface along 1 cm length of the surface. Thus, the units of [surface tension](#) are dynes per centimeter or Newton per meter i.e. Nm^{-1} in the S.I. system.

Cohesion, Adhesion, Surface Tension and Capillarity

Cohesion means inter-molecular attraction between molecules of the same liquid.

Adhesion means attraction between the molecules of a liquid and the molecules of a solid boundary surface in contact with the liquid.

Surface tension is caused by the force of cohesion at the free surface.

Capillarity is defined as the phenomenon of rise or fall of a liquid surface in a small tube relative to the adjacent general level of liquid when the tube is held vertically in the liquid. Capillarity rise or fall is due to the combined effect of adhesion and cohesion.

Compressibility

It is a [measure](#) of the relative volume change of a [fluid](#) or [solid](#) as a response to a [pressure](#) (or mean [stress](#)) change.

The choice to define compressibility as the [negative](#) of the fraction makes compressibility positive in the (usual) case that an increase in pressure induces a reduction in volume.

Characteristics of Vapour Pressure

It is inversely proportional to the forces of attraction existing between the molecules of a liquid. It increases with a rise in the temperature. This is because the molecules gain specific weight

Vapor Pressure

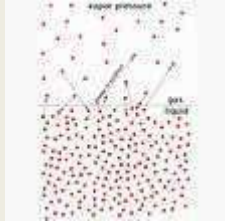

Vapor pressure or equilibrium vapor pressure is defined as the pressure exerted by a vapor in thermodynamic equilibrium with its condensed phases (solid or liquid) at a given temperature in a closed system. The equilibrium vapor pressure is an indication of a liquid's evaporation rate. It relates to the tendency of particles to escape from the liquid (or a solid). A substance with a high vapor pressure at normal temperatures is often referred to as volatile. The pressure exhibited by vapor present above a liquid surface is known as vapor pressure. As the temperature of a liquid increases, the kinetic energy of its molecules also increases. As the kinetic energy of the molecules increases, the number of molecules transitioning into a vapor also increases, thereby increasing the vapor pressure.

Viscosity

It is the property of a fluid which offers resistance to the movement of one layer of fluid over another adjacent layer of the fluid. The viscosity is an important property which offers the fluid motion.

The viscosity of liquid decreases with increase in temperature and for gas it increases with increase in temperature.

Types of Viscosity

As we know, the viscosity is the measure of the friction of fluids. There are two ways to measure a fluid's viscosity as follows:

- Dynamic Viscosity (Absolute Viscosity)
- Kinematic Viscosity

- **Dynamic Viscosity:** viscosity related to the external force applied to non-Newtonian fluids.
- **Kinematic Viscosity:** inherent viscosity of Newtonian fluids, that does not change with a change in applied force.

Dynamic (absolute) Viscosity

Absolute viscosity - coefficient of absolute viscosity - is a measure of internal resistance. Dynamic (absolute) viscosity is the tangential force per unit area required to move one horizontal plane with respect to another plane - at a unit velocity - when maintaining a unit distance apart in the fluid.

The shearing stress between the layers of a non-turbulent fluid moving in straight parallel lines can be defined for a Newtonian fluid as

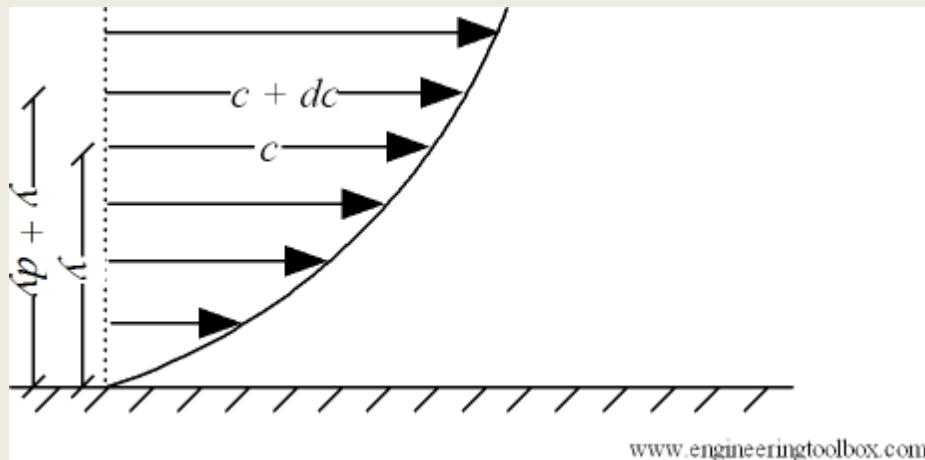

Shear stress can be expressed

$$\begin{aligned} \tau &= \mu \, dc / dy \\ &= \mu \, \gamma \end{aligned} \quad (1)$$

where

τ = shearing stress in fluid (N/m²)

μ = dynamic viscosity of fluid (N s/m²)

dc = unit velocity (m/s)

dy = unit distance between layers (m)

$\gamma = dc / dy = \text{shear rate (s}^{-1}\text{)}$

Equation (1) is known as the **Newtons Law of Friction**.

(1) can be rearranged to express **Dynamic viscosity** as

$$\begin{aligned}\mu &= \tau \, dy / dc \\ &= \tau / \gamma\end{aligned}$$

In the [SI system](#) the dynamic viscosity units are $N \, s/m^2$, $Pa \, s$ or $kg/(m \, s)$ - where

- $1 \, Pa \, s = 1 \, N \, s/m^2 = 1 \, kg/(m \, s) = 0.67197 \, lb/(ft \, s) = 0.67197 \, slug/(ft \, s) = 0.02089 \, lbs/ft^2$

Dynamic viscosity may also be expressed in the metric *CGS (centimeter-gram-second)* system as $g/(cm \, s)$, $dyne \, s/cm^2$ or **poise (p)** where

- $1 \, poise = 1 \, dyne \, s/cm^2 = 1 \, g/(cm \, s) = 1/10 \, Pa \, s = 1/10 \, N \, s/m^2$

For practical use the Poise is normally too large and the unit is therefore often divided by 100 - into the smaller unit **centipoise (cP)** - where

- $1 \, P = 100 \, cP$
- $1 \, cP = 0.01 \, poise = 0.01 \, gram \, per \, cm \, second = 0.001 \, Pascal \, second = 1 \, milliPascal \, second = 0.001 \, N \, s/m^2$

Water at 20.2°C (68.4°F) has the absolute viscosity of *one - 1 - centiPoise*.

Kinematic Viscosity

Kinematic viscosity is the ratio of - *absolute (or dynamic) viscosity to density* - a quantity in which no force is involved. Kinematic viscosity can be obtained by dividing the absolute viscosity of a fluid with the fluid mass density like

$$v = \mu / \rho$$

where

v = kinematic viscosity (m^2/s)

μ = absolute or dynamic viscosity ($N \, s/m^2$)

ρ = density (kg/m^3)

In the SI-system the theoretical unit of kinematic viscosity is m^2/s - or the commonly used **Stoke (St)** where

- $1 \, St \, (Stokes) = 10^{-4} \, m^2/s = 1 \, cm^2/s$

Stoke comes from the CGS (Centimetre Gram Second) unit system.

Since the Stoke is a large unit it is often divided by 100 into the smaller unit **centiStoke (cSt)** - where

- 1 St = 100 cSt
- 1 cSt (centiStoke) = $10^{-6} \text{ m}^2/\text{s} = 1 \text{ mm}^2/\text{s}$
- $1 \text{ m}^2/\text{s} = 10^6 \text{ centiStokes}$

Many are confused between the two viscosity measures and consider them to be one and the same. In reality, they have significant differences between them. For a few applications, kinematic viscosity is more useful than absolute or dynamic viscosity.

Example: Calculate the specific weight, mass density, specific gravity and specific volume of oil having a volume of 4.5 m^3 and weight of 40 kN .

Solution:

1. Specific weight:

$$w = \frac{\text{weight of oil}}{\text{Volume of oil}} = \frac{40 \times 10^3}{4.5} = 8.889 \times 10^3 \text{ N/m}^3 \quad \text{ANS.}$$

2. Mass density of oil

$$p = \frac{\text{specific weight of oil}}{\text{Acceleration due to gravity}} = \frac{w}{g}$$

$$= \frac{8.889 \times 10^3}{9.81} = 906.1 \text{ kg/m}^3 \quad \text{ANS.}$$

3. Specific gravity of oil

$$S = \frac{\text{Specific weight of oil}}{\text{Specific weight of water}} = \frac{8.889 \times 10^3}{9.81 \times 10^3} = 0.906 \quad \text{ANS.}$$

4. Specific volume of oil

$$v = \frac{1}{p} = \frac{1}{906.1} = 1.1 \times 10^{-3} \text{ m}^3/\text{kg} \quad \text{ANS.}$$

Exercises

Section -1

Multiple choice questions:-

1. Which one of the following is the unit of specific weight?

- a) $N = m^3$
- b) $N = m^2$
- c) $N = m$
- d) $N = ms$

2. Two fluids 1 and 2 have mass densities of p_1 and p_2 respectively. If $p_1 > p_2$, which one of the following expressions will represent the relation between their specific volumes v_1 and v_2 ?

- a) $v_1 > v_2$
- b) $v_1 < v_2$
- c) $v_1 = v_2$
- d) Cannot be determined due to insufficient information.

3. Which one of the following is the dimension of specific weight of a liquid?

- a) $[ML^{-3} T^{-2}]$.
- b) $[ML^3 T^{-2}]$.
- c) $[ML^{-2} T^{-2}]$.
- d) $[ML^2 T^{-2}]$.

4. Which one of the following is the dimension of specific gravity of a liquid?

- a) $[M^1 L^{-3} T^0]$.
- b) $[M^1 L^0 T^0]$.
- c) $[M^0 L^{-3} T^0]$.
- d) $[M^0 L^0 T^0]$.

5. Which one of the following is the dimension of mass density?

- a) $[M^1 L^{-3} T^0]$.
- b) $[M^1 L^3 T^0]$.
- c) $[M^0 L^{-3} T^0]$.
- d) $[M^0 L^3 T^0]$.

6. The specific gravity of a liquid has

- a) the same unit as that of mass density
- b) the same unit as that of weight density
- c) the same unit as that of specific volume
- d) no unit

7. A beaker is filled with a liquid up to the mark of one litre and weighed. The weight of the liquid is found to be 6.5 N. The specific volume of the liquid will be

- a) $1 \text{ l} = \text{kg}$

b) $1:5 \text{ l} = \text{kg}$

c) $2 \text{ l} = \text{kg}$

d) $2:5 \text{ l} = \text{kg}$

Section -2

Short Answer-Type Questions:-

1. Define mass density.
2. Define specific gravity.
3. What do you understand by vapour pressure?
4. What do you mean by capillarity?
5. What is viscosity?
6. Define cohesion, adhesion and surface tension.

Chapter 3

Hydrostatic Pressure

Hydrostatic pressure

is the **pressure** that is exerted by a fluid at equilibrium at a given point within the fluid, due to the force of gravity. **Hydrostatic pressure** increases in proportion to depth measured from the surface because of the increasing weight of fluid exerting downward force from above.

The force/pressure per unit area is called pressure intensity or unit pressure or specific pressure. If P is pressure/force on area A , then intensity of pressure.

$$p = P/A$$

Pressure head of liquid

$$p = \text{weight of liquid in the cylinder} / \text{Area of the cylinder base}$$

$$= whA/A = wh$$

$$p = wh$$

$$h = p/w$$

w = specific weight of liquid

h = Height of liquid in the cylinder

A = Area of cylinder base

EXAMPLE 3.1.1 Find the pressure at a depth 20m below the free surface of water in reservoir.

SOLUTION. Depth of water, h=20m

Specific weight of water=9810N/m³

Now p = wh

$$p = 9810 \times 20 = 196200 \text{ N/m}^2 (\text{Pascal})$$

$$= 196.2 \text{ KN/m}^2 (\text{kPa})$$

Pascal's Law Derivation

Consider an arbitrary right angled prismatic triangle in the liquid of density ρ . Since the prismatic element is very small, every point is considered to be at the same depth from the liquid surface. The [effect of gravity](#) is also same at all these points.

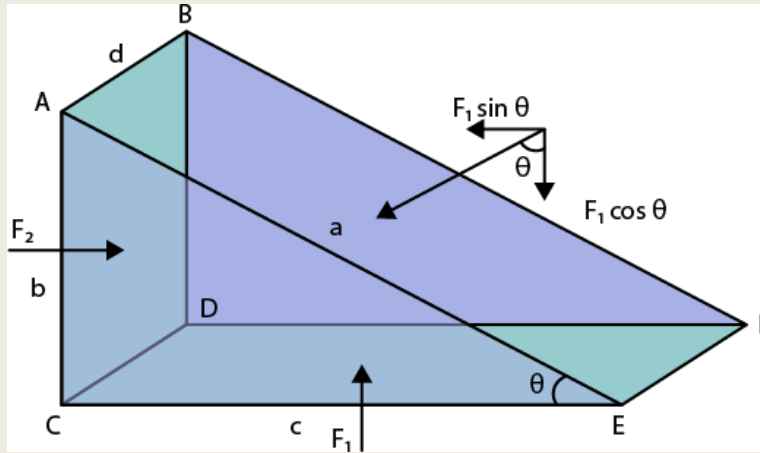

Fig 3.1

Let ad , bd , and cd be the area of the faces $ABFE$, $ABDC$, and $CDFE$ respectively.

Let P_1 , P_2 , and P_3 be the pressure on the faces $ABFE$, $ABDC$, and $CDFE$.

Pressure exerts force which is normal to the surface. Let P_1 exert force F_1 on the surface $ABFE$, P_2 exert force F_2 on the surface $ABDC$, and P_3 exert force F_3 on the surface $CDFE$.

Therefore, Force F_1 , F_2 , and F_3 is given as:

$$F_1 = P_1 \times \text{area of } ABFE = P_1 ad$$

$$F_2 = P_2 \times \text{area of } ABDC = P_2 bd$$

$$F_3 = P_3 \times \text{area of } CDFE = P_3 cd$$

$$\text{Also, } \sin\theta = \frac{bd}{a} \quad \cos\theta = \frac{cd}{a}$$

The net force on the prism will be zero since the prism is in equilibrium.

$$F_1 \sin \theta = F_2$$

$$F_1 \cos \theta = F_3$$

$$P_1 ad \frac{bd}{a} = P_2 bd \quad (\text{equ 1})$$

$$P_1 ad \frac{cd}{a} = P_3 cd \quad (\text{equ 2})$$

From 1 and 2
 $P_1 = P_2$ and $P_1 = P_3$

$\therefore P_1 = P_2 = P_3$

Example of Pascal's Law

Let us understand the working principle of Pascal's law with an example.

A pressure of 2000 Pa is transmitted throughout a liquid column due a force being applied on a piston. If the piston has an area of 0.1 m^2 , what is the force applied?

This can be calculated using Pascal's Law formula.

$$F = PA$$

Here,

$$P = 2000 \text{ Pa} = \text{N/m}^2$$

$$A = 0.1 \text{ m}^2$$

Substituting values, we arrive at $F = 200 \text{ N}$

Applications of Pascal's Law

- Hydraulic Lift: The image you saw at the beginning of this article is a simple line diagram of a hydraulic lift. This is the principle of working of hydraulic lift. It works based on the principle of equal pressure transmission throughout a fluid (Pascal's Law).
- The construction is such that a narrow cylinder (in this case A) is connected to a wider cylinder (in this case B). They are fitted with airtight pistons on either end. The inside of the cylinders are filled with an incompressible fluid.
- Pressure applied at piston A is transmitted equally to piston B without diminishing, on use of an incompressible fluid. Piston B effectively serves as a platform to lift heavy objects like big machines or vehicles. Few more applications include a hydraulic jack and hydraulic press and forced amplification is used in the braking system of most cars.

Total Pressure and Centre of Pressure

The total pressure is defined as the force exerted by a static fluid on a surface (either plane or curved) when the fluid comes in contact with the surface. This force is always normal to the surface. The centre of pressure is defined as the point of application of the resultant pressure on the surface.

It is defined as the force exerted by a static fluid on a surface (either plane or curved) when the fluid comes in contact with the surface. This force is always acts at right angle (or normal) to the surface.

Let us consider a plate hinged at the top is subjected to hydrostatic pressure. The pressure varies according to the depth of water as shown in fig.

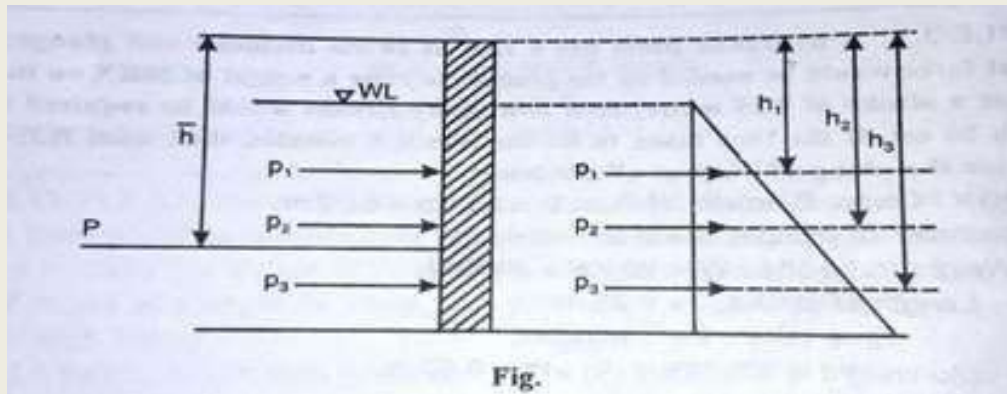

All lateral pressures may be replaced by a single pressure 'P' known as total pressure or resultant pressure which is equal to

$$P = p_1a_1 + p_2a_2 + p_3a_3 + \dots\dots\dots p_n a_n.$$

where $p_1, p_2, p_3, \dots\dots\dots p_n$ = intensity of pressure on different strips of the surface.

$a_1, a_2, a_3, \dots\dots\dots a_n$ = Area of corresponding strips.

CENTRE OF PRESSURE

It is defined as the point of application of the total pressure on the surface.

Now from fig. we can see that moment of the lateral pressure about the hinge must be equal to the moment of P about the hinge.

This gives us line of action of P. The point on the surface at which the resultant pressure acts is known as centre of pressure.

The total pressure and centre of pressure on the immersed surfaces are as follows:

1. **Horizontally immersed surface.** The total pressure on a horizontally immersed surface, is given by

$$P = wA \bar{y}$$

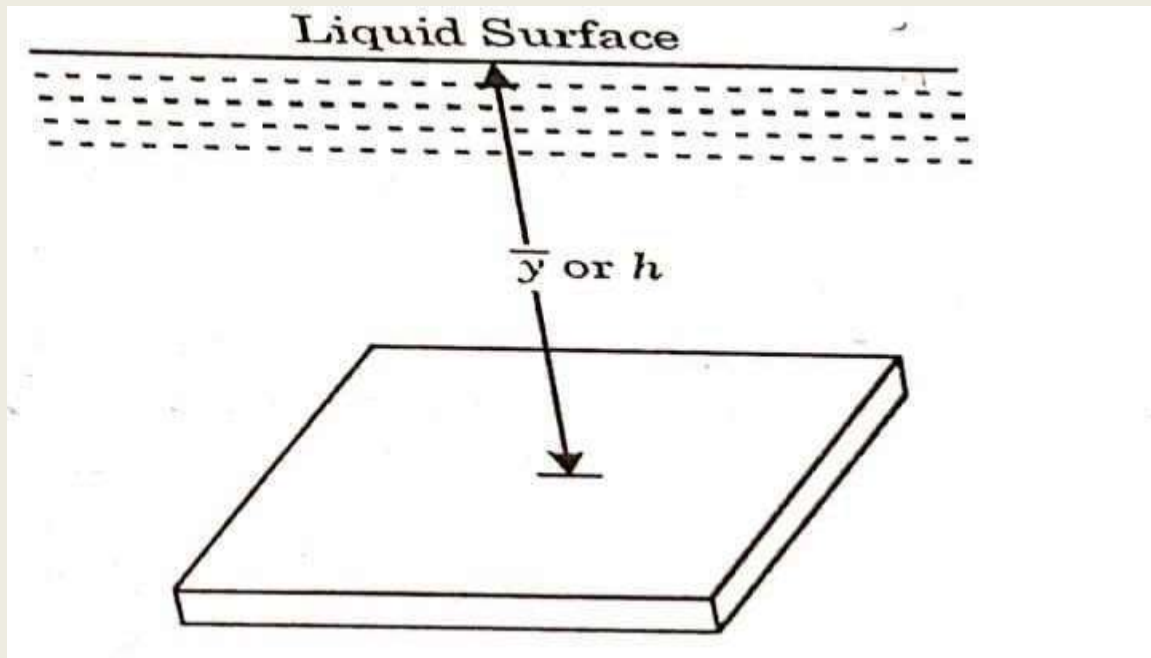

where

w = Specific weight of the liquid,

A = Area of the immersed surface, and

\bar{y} (bar) = Depth of the centre of gravity of the immersed surface from the liquid surface.

The above expression holds good for all surfaces whether flat or curved.

2. **Vertically immersed surface.** The total pressure on a vertically immersed surface, is given by

$$P = wA \bar{y}$$

$$\text{Centre of pressure: } h(\text{bar}) = \bar{y} + I_G / A \bar{y}$$

and the depth of centre of pressure from the liquid surface,

where

$h(\text{bar})$ = Depth of centre of pressure

$y(\text{bar})$ = Depth of centre of gravity of the immersed surface from the liquid surface, and

I_G = Moment of inertia of immersed surface about the horizontal axis through its centre of gravity

Example: A circular plate of diameter 1.6m is placed vertically in water in such a way that the centre of plate is 3m below the free surface of water.

Determine: (a) Total pressure on the plate

(b) Position of centre of pressure.

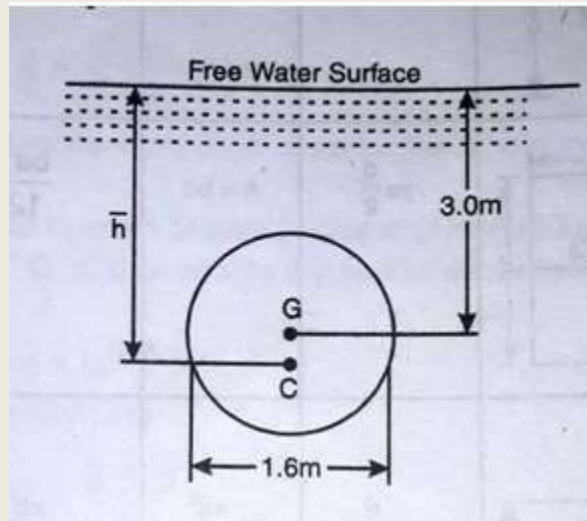

Solution. Given

Diameter of plate = 1.6m,

Depth of C.G. of plate below free water surface = 3.0 m, or $\bar{y} = 3.0$ m

Hence area of plate

$$A = \frac{\pi}{4} \times d^2$$
$$= \frac{\pi}{4} \times 1.6^2 = 2.011 \text{ m}^2$$

As we know that sp. wt. of water = 9810 N/m³

$$w = 9810 \text{ N/m}^3$$

(i) Total pressure on plate

$$P = w A \bar{y}$$
$$= 9810 \times 2.011 \times 3.0$$
$$= 59172.5 \text{ N}$$
$$= 59.17 \text{ kN}$$

ANS.

(ii) Position of centre of pressure

$$\bar{h} = \bar{y} + \frac{I_G}{A\bar{y}}$$

$$I_G = \frac{\pi}{64} d^4 = \frac{\pi}{64} \times 1.6^4 = 0.322 \text{ m}^4$$

$$\bar{h} = 3.0 + \frac{0.322}{2.011 \times 3.0}$$
$$= 3.053 \text{ m}$$

ANS.

Example: A rectangular plate 4m long and 2m wide is immersed vertically in water in such a way that its 4m side is parallel to the water surface and is 1.5m below it.

Determine (a) Total pressure on the plate

(b) Position of centre of pressure.

Solution.

$$\text{Size of plate} = 4\text{m} \times 2\text{m}$$
$$\text{Area of plate} = 8 \text{ m}^2$$
$$\bar{y} = 1.5 + \frac{2}{2} = 2.5 \text{ m}$$

$$\begin{aligned}
 \text{Sp.wt. of water (w)} &= 9810 \text{ N/m}^3 \\
 \text{Hence total pressure on plate} &= wA\bar{y} \\
 &= 9810 \times 8 \times 2.5 \\
 &= 196200 \text{ N} \\
 &= 196.2 \text{ kN}
 \end{aligned}$$

Position of centre of pressure is given by

$$\begin{aligned}
 \bar{h} = \bar{y} &= \frac{I_G}{A\bar{y}} \\
 \text{Where } I_G &= \frac{bd^3}{12} = \frac{4 \times 2^3}{12} = 2.67 \text{ m}^4 \\
 \bar{h} &= 2.5 + \frac{2.67}{8 \times 2.5} \\
 &= 2.5 + 0.133 \\
 &= 2.633 \text{ m}
 \end{aligned}$$

Example: A triangular plate of base width 1.5m and height 2m lies immersed in water with apex downwards. The base of plate is 1 m below and parallel to free water surface. Workout total pressure on plate and locate the position of centre of pressure with respect to plate centroid.

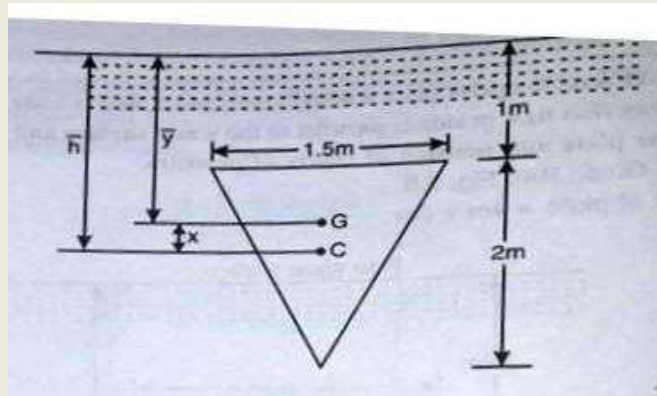

Solution:

Given, Base width of triangular plate = 1.5 m.

Height of triangular plate = 2.0 m

$$\text{Now } \bar{y} = 1 + \frac{1}{3} \times 2.0 = 1.667 \text{ m.}$$

$$\text{Area of plate (A)} = \frac{1}{2} bh$$

$$= \frac{1}{2} \times 1.5 \times 2.0 = 1.5 \text{ m}^2$$

Specific weight of water (w) = 9810 N/m³

Hence total pressure on plate

$$\begin{aligned}
 P &= wA\bar{y} \\
 &= 980 \times 1.5 \times 1.667 \\
 &= 24525 \text{ N} \\
 &= 24.525 \text{ kN.}
 \end{aligned}$$

ANS.

Position of centre of pressure with respect to free water surface is given by

$$\begin{aligned}
 \bar{h} &= \bar{y} + \frac{I_G}{A\bar{y}} \\
 \text{Where } I_G &= \frac{bh^3}{36} = \frac{1.5 \times 2^3}{36} = 0.333 \text{ m}^4 \\
 \bar{h} &= 1.667 + \frac{0.333}{1.5 \times 1.667} = 1.80 \text{ m}
 \end{aligned}$$

Now position of centre of pressure with respect to centroid (centre of gravity) of plate

$$\begin{aligned}
 &= \bar{h} - \bar{y} \\
 &= 1.80 - 1.667 \\
 &= 0.133 \text{ m}
 \end{aligned}$$

ANS.

3. **Inclined immersed surface.** The total pressure on an inclined surface, is given by

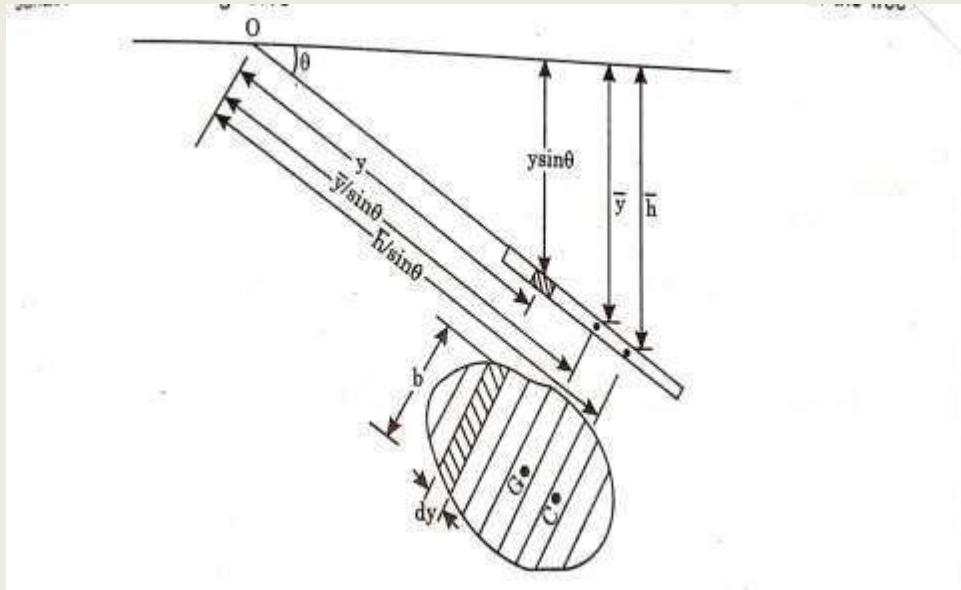

$$P = wA \bar{y}$$

$$\text{Centre of pressure: } h(\bar{h}) = \bar{y} + I_G \sin^2 \theta / A \bar{y}$$

and the depth of centre of pressure from the liquid surface,

where

\bar{h} = Depth of centre of pressure

\bar{y} = Depth of centre of gravity of the immersed surface from the liquid surface, and

I_G = Moment of inertia of immersed surface about the horizontal axis through its centre of gravity

where

θ = Angle at which the immersed surface is inclined with the liquid surface.

Example: A rectangular plate 2m wide and 3m deep is immersed in water in such a way that its plane makes an angle 30° with the water surface. Determine the total pressure and centre of pressure when the upper edge is 1.2m below the free water surface.

Given Size of plate, width, $b = 2$ m

Depth, $d = 3$ m

Area of plate = $2 \times 3 = 6$ m²

Angle of Inclination, $\theta = 30^\circ$

Now from $\triangle LMN$

MN

$$\frac{MN}{LN} = \sin 30^\circ$$

$$MN = LN \sin 30^\circ$$

$$= 1.5 \times \frac{1}{2} = 0.75 \text{ m.}$$

Hence $\bar{y} = 1.2 + 0.75 = 1.95$ m

Specific gravity of water, $w = 9810$ N/m³

Total pressure on plate, $P = wA\bar{y}$

$$= 9810 \times 6 \times 1.95$$

$$= 114777 \text{ N}$$

$$= 114.77 \text{ kN}$$

For Centre of Pressure

$$h = \bar{y} + \frac{I_G \sin^2 \theta}{A \bar{y}}$$

$$I_G = \frac{bd^3}{12} = \frac{2 \times 3^3}{12} = 4.5 \text{ m}^4$$

$$\begin{aligned} \bar{h} &= 1.95 + \frac{4.5 \sin^2 30^\circ}{6 \times 1.95} \\ &= 2.046 \text{ m} \end{aligned}$$

ANS.

Example: A circular plate of 3m diameter is immersed in water, its greatest and least depth below the free surface being 4m and 2.5m respectively. Determine the total pressure on face of plate and position of centre of pressure

Sol: Given diameter of plate, $d=3.0 \text{ m}$

$$\text{Area of plate, } A = \pi/4 \cdot d^2 = \pi/4 \cdot 3.0 \cdot 3.0 = 7.068 \text{ m}^2$$

From $\triangle LMN$

$$MN/LN = \sin \theta$$

$$\sin \theta = \frac{(4.0-2.5)}{3.0} = \frac{1.5}{3.0} = \frac{1}{2}$$

$$\text{Hence } \theta = \sin^{-1} \left(\frac{1}{2} \right)$$

$$\text{or } \theta = 30^\circ$$

Now from LPQ

PQ

$$\frac{PQ}{LQ} = \sin \theta$$

$$PQ = LQ \sin 30^\circ$$

$$= 1.5 \sin 30^\circ$$

$$PQ = 1.5 \times \frac{1}{2} = 0.75$$

so

$$\bar{y} = 2.5 + 0.75$$

$$= 3.25 \text{ m}$$

(i) Total pressure on plate

$$P = w A \bar{y}$$

$$= 9810 \times 7.068 \times 3.25$$

$$= 225345.5 \text{ N}$$

$$= 225.345 \text{ kN}$$

ANS.

(ii) Depth of centre of pressure

$$\bar{h} = \bar{y} + \frac{I_G \sin \theta}{\bar{A} y}$$

$$I_G = \frac{\pi}{64} d^4 = \frac{\pi}{64} \times 3^4 = 3.976 \text{ m}^4$$

$$\bar{h} = 3.25 + \frac{3.976 \sin^2 30^\circ}{7.068 \times 3.25}$$

$$= 3.293 \text{ m}$$

ANS.

[Numerical Problems]

Ex1: Calculate the pressure in pascals corresponding to

- 8cm column of a liquid of specific gravity 0.80
- 6cm column of mercury
- 2.0cm column of water

[Ans. (a) 626.6 Pa (b) 7988.6 Pa (c) 19.58 Kpa]

Ex2: Determine the total pressure on a circular plane of diameter 1.5m which is placed vertically in the water in such a way that centre of plate is 2m below the free surface of water. Find the position of centre of pressure also.

[Ans. 34668.54N, 2.07m]

Ex3: Determine the total pressure and centre of pressure on an isosceles triangular plate of base 5m and altitude 5m when the plate is immersed vertically in an oil of sp. gr. 0.8. The base of the plate is 1m below the surface of water.

[Ans. 261927N, 3.19m]

Ex4: Determine the total pressure and depth of centre of pressure on a plane rectangular surface of 1m wide and 3m deep when its upper edge is horizontal and (a) coincides with water surface (b) 2m below the free water surface.

[Ans (a) 44145N, 2.0m (b) 103005N, 3.714m]

Ex5: A triangular plate of 1m base and 1.8m altitude is immersed in water. The plane of the plate is inclined at 30° with the free water surface and the base is parallel to and at a depth of 2m from water surface. Find the total pressure on the plate and position of the centre of pressure.

[Ans. 20.31 kN, 2.32m]

Ex6: Find the intensity of pressure at the bottom of a container containing 0.6m depth of oil of specific gravity 0.75 above 1.5m depth of water. Assume both liquids being immiscible.

[Ans. 19.13kN/m²]

Ex7: A triangular plate of 2m base and 3.0m altitude is immersed in an oil. The plane of the plate is inclined at 25° with free oil surface and base is parallel to and at a depth of 1.5m from free oil surface. Find the total pressure on the plate and the position of centre of pressure. Specific gravity of oil is to be taken 0.78.

[Ans. P=44.13 kN, h(bar)= 1.969m]

CHAPTER - 4

MEASUREMENT OF PRESSURE

MEASUREMENT OF PRESSURE

Introduction

Pressure measurement is one of the most common of all measurements made on systems. Pressure along with flow measurements is extensively used in industry, laboratories and many other fields for a wide variety of reasons. Pressure measurements are concerned not only with determination of force per unit area but are also involved in many liquid level, density, flow and temperature measurements.

Pressure

Pressure is the force per unit area exerted by a fluid on the surface of the container. Pressure measurements, are usually made relative to some reference. Everyday pressure measurements, such as, the pressure in a car tire, are usually made relative to ambient air pressure. In other cases measurements are made relative to a vacuum or to some other ad hoc reference. When distinguishing between these zero references, the following terms are used:

i) Atmospheric pressure

The atmospheric air exerts a normal pressure upon all surfaces with which it is in contact, and it is known as atmospheric pressure. The atmospheric pressure varies with the altitude and it can be measured by means of a barometer. As such it is also called the barometric pressure.

At sea level under the normal conditions the equivalent values of the atmospheric pressure are $10.1043 \times 10^4 \text{ N/m}^2$ or 1.03 kg(f)/cm^2 or 10.3 m of water or 76 cm of mercury.

ii) Absolute pressure

It is known that pressure is force per unit area when the interaction of fluid particles among themselves is zero, a zero pressure intensity will occur. This is possible only when the population of molecules is negligibly small which means perfect vacuum. Hence the pressure intensity measured from a state of perfect vacuum is called as absolute pressure. So it is equal to gauge pressure plus atmospheric pressure

iii) Gauge Pressure

A pressure measuring instrument generally measures the difference between the unknown pressure (P) and the atmospheric pressure (P_{ata}). When the unknown pressure (P) is greater than the atmospheric pressure (P_{atm}), the pressure measured by the instrument is called as the gauge

pressure. In Gauge pressure is zero referenced against ambient air pressure, so it is equal to absolute pressure minus atmospheric pressure. Negative signs are usually omitted.

iv) Vacuum pressure

A Pressure measuring instrument generally measures the difference between the unknown pressure (P) and the atmospheric pressure (P_{atm}). When the atmospheric pressure (P_{atm}) is greater than the unknown pressure (P), the pressure measured by the instrument is called as the vacuum pressure

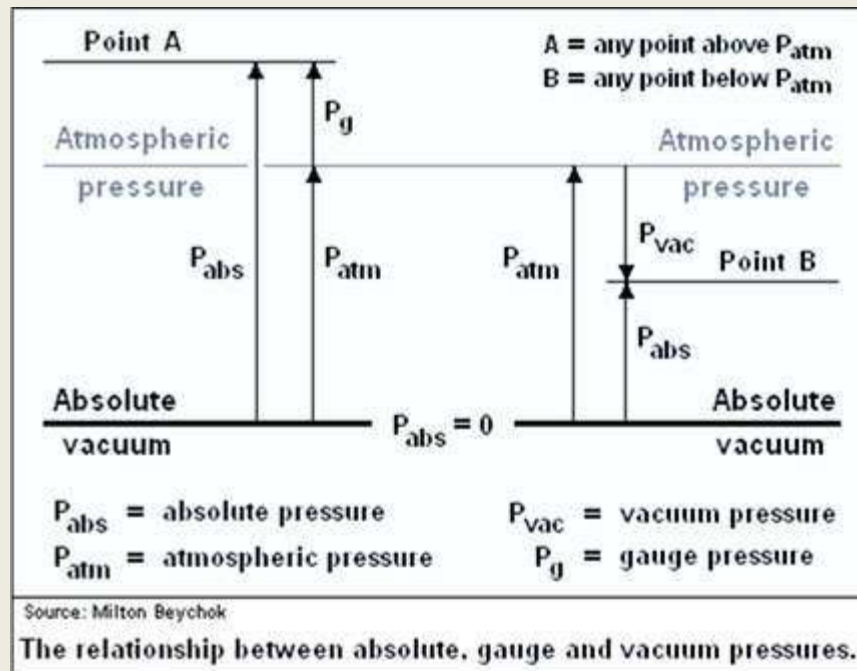

Fig. 1

$$\text{Absolute pressure} = \text{Atmospheric pressure} + \text{Gauge pressure}$$

$$\text{Absolute pressure} = \text{Atmospheric pressure} - \text{Vacuum pressure}$$

v) Static and Dynamic Pressure

Static pressure is uniform in all directions, so pressure measurements are independent of direction in an immovable (static) fluid. Flow, however, applies additional pressure on surfaces perpendicular to the flow direction, while having little impact on surfaces parallel to the flow direction. This directional component of pressure in a moving (dynamic) fluid is called dynamic pressure.

Table 4.1 Units of pressure measurement

Pressure Units						
	pascal (Pa)	bar (bar)	atmosphere (atm)	torr (torr)	pound-force per square inch (psi)	kilogram-force per square centimeter (kgf/cm ²)
1 Pa	≡ 1 N/m ²	10 ⁻⁵	9.8692×10 ⁻⁶	7.5006×10 ⁻³	145.04×10 ⁻⁶	1.01972×10 ⁻⁵
1 bar	100,000	≡ 10 ⁶ dyn/cm ²	0.98692	750.06	14.504	1.01972
1 atm	101,325	1.01325	≡ 1 atm	760	14.696	1.03323
1 torr	133.322	1.3332×10 ⁻³	1.3158×10 ⁻³	≡ 1 torr ≈ 1 mmHg	19.337×10 ⁻³	1.35951×10 ⁻³
1 psi	6,894.76	68.948×10 ⁻³	68.046×10 ⁻³	51.715	≡ 1 lbf/in ²	7.03059×10 ⁻²
1 kgf/cm²	98,066.5	0.980665	0.967838	735.5576	14.22357	≡ 1 kgf/cm ²

Example reading: 1 Pa = 1 N/m² = 10⁻⁵ bar = 9.8692×10⁻⁶ atm = 7.5006×10⁻³ torr, etc.
Note: mmHg is an abbreviation for millimetre of mercury

Example : The reading of a barometer is found to be equal to 740 mm of mercury. What shall be the value of atmospheric pressure in terms of water and N/m² if the specific gravity of mercury is 13.6?

Solution:

Let h₁ = Atmospheric pressure in terms of head of water.

Using the relation,

$$S_1 h_1 = S_2 h_2$$

$$1 \times h_1 = 13.6 \times 740$$

(Specific gravity of water = 1)

$$h_1 = 10064 \text{ mm} = 10.064 \text{ m of water}$$

$$p = wh$$

$$p = 9810 \times 10.064 = 98728 \text{ N/m}^2$$

ANS.

Example : The barometric pressure at sea level is 760 mm of mercury. If the specific gravity weight of air is 12 and N/m², what will be the pressure on the top of a mountain 278 m high?

Solution:

Pressure at sea level (Pressure at the base of mountain), p_{base} = 760 mm of mercury

$$= 0.76 \text{ m of mercury} = 13.6 \times 9810 \times 0.76 = 101396 \text{ and N/m}^2$$

Height of mountain, $h = 278 \text{ m}$

Specific weight of air, $w = 12 \text{ and N/m}^2$

Let $P_{\text{top}} = \text{Pressure at the top of mountain.}$

$$P_{\text{base}} - P_{\text{top}} = wh$$

$$101396 - P_{\text{top}} = 12 \times 278$$

$$P_{\text{top}} = 101396 - 12 \times 278 = 98060 \text{ N/m}^2$$

$$P_{\text{top}} = \frac{98060}{13.6 \times 9810} = 0.735 \text{ m of mercury.}$$

ANS

Example : At a certain place the atmospheric pressure was found to be equal to 700 mm of mercury. Find out the absolute pressure in the following cases when :

(i) Gauge pressure is 1.4 m of water

(ii) Vacuum pressure is 2.4 m of water.

Solution:

Atmospheric pressure, $P_{\text{atm}} = 700 \text{ mm of mercury} = 0.70 \text{ m of mercury}$

$$= 0.70 \times 13.6 \times 9810 = 93391 \text{ N/m}^2$$

(i) Gauge pressure, $P_{\text{gauge}} = 1.4 \text{ m of water}$

$$= 1.4 \times 9810 = 13734 \text{ N/m}^2$$

Absolute pressure, $P_{\text{abs}} = P_{\text{atm}} + P_{\text{gauge}}$

$$= 93391 + 13734 = 107125 \text{ N/m}^2 = 107.125 \text{ kN/m}^2 \quad \text{ANS.}$$

(ii) Vacuum pressure, $P_{\text{vac}} = 2.4 \text{ m of water}$

$$= 2.4 \times 9810 = 23544 \text{ N/m}^2$$

Absolute pressure, $P_{\text{abs}} = P_{\text{atm}} - P_{\text{vac}}$

$$= 93391 - 23544 = 69847 \text{ N/m}^2 = 69.847 \text{ kN/m}^2 \quad \text{ANS.}$$

Measurement of Pressure

Many instruments have been invented to measure pressure, with different advantages and disadvantages. Pressure range, sensitivity, dynamic response and cost all vary by several orders of magnitude from one instrument design to the next. The oldest type is the liquid column (a vertical tube filled with mercury) manometer. Following table gives the instruments which are used in various situations:

1. Manometers
2. Mechanical gauge

1. **Manometer** :- manometer are defined as devices used to measure the pressure at in a point in a fluid. These are also used a measure the difference in pressure between two points in s pipes or in two different pipes.

Principle of manometers:- manometer are based on the principle of balancing the column of fluid by the same or another column of the fluid.

Classification of manometers:-

a) Simple manometer

- i. Piezometer
- ii. U-tube manometer
- iii. Single column manometer

b) Differential manometers.

2. Mechanical gauges:- mechanical gauges are defined as devices used to measure pressure. Mechanical gauges are based on the principle of balancing the column of fluid by the spring or dead weight

Classification of mechanical gauges:-

- a) Bourden's tube pressure gauge
- b) Diaphragm pressure gauge
- c) Dead weight pressure gauge
- d) Bellow pressure gauges

Simple Manometers

It consists of a glass tube with one end open to the atmosphere and other end connected to a point at which pressure is to be measured.

a. Piezometer

It consists of glass tube connected to a vessel or pipe at which static pressure is to be measured. It is the simplest of all the manometers (Fig. 2). It is used to measure very low pressures.

The pressure in piezometer is given by the following equation.

$$P = wh$$

Where,

w = specific weight of liquid

h = height of liquid in the piezometer from the centre of the pipe.

- 3. U-tube Manometer (Double column manometer).** It consists of a glass tube bent in U-shape. One end of this tube is connected to a point at which pressure is to be measured and the other end remains open to the atmosphere. The tube generally contains a liquid (called manometric liquid or balancing liquid) whose specific gravity is greater than the specific gravity of the liquid whose pressure is to be measured.

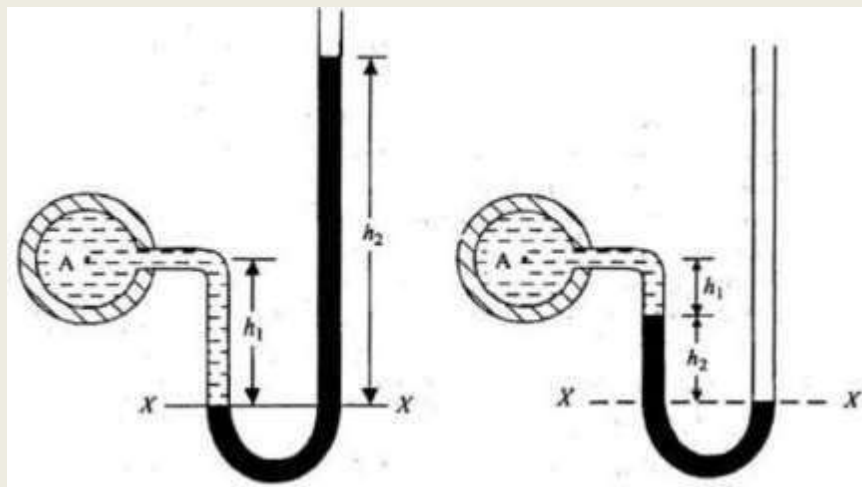

(a) For gauge pressure

(b) For vacuum pressure

Fig. 3

(a) **For gauge pressure.** Let A is the point at which pressure is to be measured as shown in Fig. 3 (a). X-X is the datum line (The horizontal surface, at which the heavy and light liquid meet in the limb, is known as datum line or common surface).

Let h_1 = Height of the light liquid in the left limb above the datum line

h_2 = Height of the heavy liquid in the right limb above the datum line

h_A = Pressure in pipe, expressed in terms of head of water

S_1 = Specific gravity of light liquid

S_2 = Specific gravity of heavy liquid.

The pressures or pressure heads in the left limb and right limb above the datum line

X-X are equal (because pressure or pressure head is same for the horizontal surface).

Pressure head above x-x in the left limb = $h + h_1 S_1$

Pressure head above x-x in the right limb = $h_2 S_2 + 0 = h_2 S_2$

(Atmospheric pressure i.e. zero gauge pressure at the free surface)

Equating equations (i) and (ii), we get

$$h_A + h_1 S_1 = h_2 S_2$$

$$h_A = h_2 S_2 - h_1 S_1$$

$$\frac{P_A}{w} = h_A = h_2 S_2 - h_1 S_1$$

(b) **For vacuum pressure (Negative pressure)** Refer Fig. 3 (b).

Pressure head above x-x in the left limb = $h + h_1 S_1 + h_2 S_2$

Pressure head above x-x in the right limb = 0

Equating equations (iii) and (iv), we get

$$h_A + h_1 S_1 + h_2 S_2 = 0$$

$$h_A = - (h_2 S_2 + h_1 S_1)$$

$$\frac{P_A}{w} = h_A = - (h_2 S_2 + h_1 S_1)$$

Note. The following steps should be followed to solve the problems on manometers :

(i) Start from one end, either from free end or from point A. Write pressure head at that point. At the open end, the pressure is zero (being atmospheric).

(ii) To the above pressure, add change in pressure, likely to be caused while proceeding from one level to another adjacent level of contact of liquid of different specific gravity.

If the next level is lower than the first, take positive sign and if the next level is higher than the first, take negative sign.

(iii) Continue above process till you reach the other end.

(iv) Solve for the unknown.

4. Single Column Manometer (Micromanometer). Single column manometer is used for measuring small pressures where accuracy is of much importance. It is a modified form of U-tube manometer. A reservoir (or basin) is connected to one of the limbs (say left). The

cross-sectional area of reservoir is much larger (about 100 times) than that of the other limb as shown fig.4

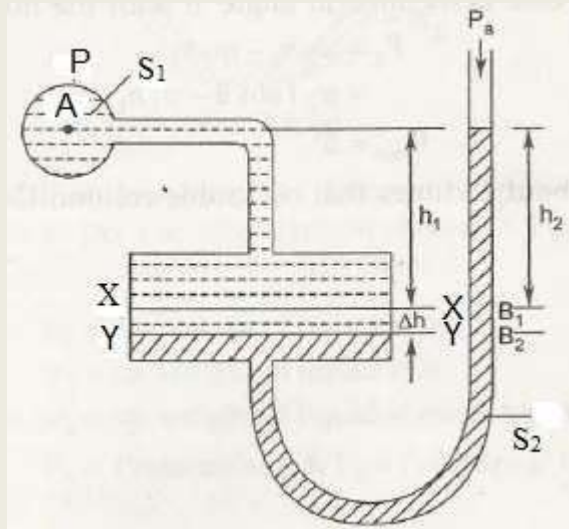

Vertical Single Column Manometer

Fig. 4

For any variation in pressure, the change in the liquid level in the reservoir will be so small that it may be neglected. Hence the pressure is given by the height of liquid in the other limb. Due to this reason the reservoir is not made transparent.

Types of single column manometers. There are two important types of single column manometers :

- (a) Vertical single column manometer
- (b) Inclined single column manometer.

(a) Vertical single column manometer. Fig. 4 shows the vertical single column manometer. X-X is the original datum line when the manometer is not connected to the pipe. When the manometer is connected to the pipe, due to high pressure in the pipe, the heavy liquid in the reservoir will be pushed downward and will rise in the right limb. Y-Y is the final datum line after the manometer is connected with the pipe.

- Let
- Ah = Fall of heavy liquid in reservoir
 - h_1 = Height of centre of pipe above X-X
 - h_2 = Rise of heavy liquid in the right limb
 - h_A = Pressure at A, (in the pipe) which is to be measured in terms of head of water
 - A = Cross-sectional area of the reservoir

a = Cross-sectional area of the right limb
 S_1 = Specific gravity of light liquid in pipe
 S_2 = Specific gravity of heavy liquid.

Fall of heavy liquid in reservoir; will cause a rise of heavy liquid level in the right limb.

$$A \times \Delta h = a \times h_2$$

$$\Delta h = \frac{a \times h_2}{A} \quad \dots\dots(i)$$

Considering the datum line Y– Y :

$$\text{Pressure head in the left limb} = h_A + (h_1 + \Delta h)S_1$$

$$\text{Pressure head in the right limb} = (\Delta h + h_2)S_2$$

Equating these pressures, we get

$$h_A + (h_1 + \Delta h)S_1 = (\Delta h + h_2)S_2$$

$$h_A = (\Delta h + h_2)S_2 - (h_1 + \Delta h)S_1$$

$$h_A = \Delta h(S_2 - S_1) + h_2S_2 - h_1S_1$$

$$h_A = \frac{a \times h_2}{A}(S_2 - S_1) + h_2S_2 - h_1S_1 \quad \left(\Delta h = \frac{a \times h_2}{A}\right)$$

As the area A is very large as compared to area a , hence ratio $\frac{a}{A}$ is very small and can be neglected.

$$h_A = h_2S_2 - h_1S_1 \quad \dots\dots(ii)$$

(b) Inclined single column manometer. This manometer is more sensitive than vertical single column manometer. It is useful for the measurement of small pressures. Due to inclination the distance moved by the heavy liquid in the right limb will be more. Refer fig 5.

Let L = Length of the heavy liquid moved in the right limb from X-X

θ = inclination of right limb with horizontal

h_2 = Vertical rise of heavy liquid in the right limb from X-X = $L \sin\theta$

from equation (ii) pressure head at A is

$$h_A = h_2S_2 - h_1S_1$$

substituting the value of h_2 , we get

$$h_A = L \sin\theta \times S_2 - h_1 S_1$$

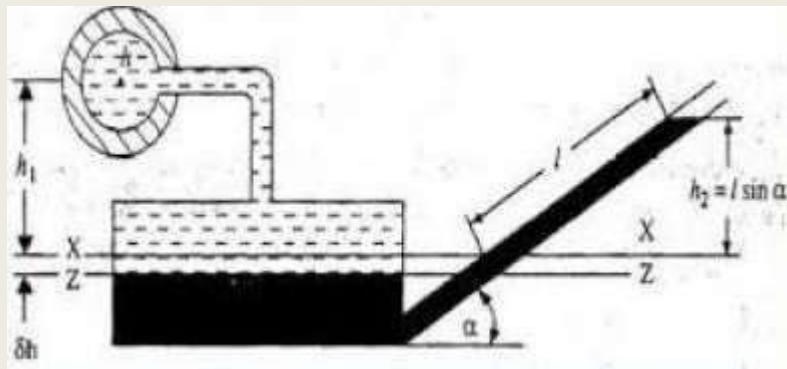

Inclined single column manometer

Fig 5

Example: A piezometer tube is fitted to a tank containing water at a point 0.50 m above bottom of tank. The liquid in manometer is carbon disulphide having specific gravity as 1.9. Determine the height of free surface above the bottom of the tank. The pressure reading in the piezometer is 0.40 m. Also find out the pressure intensity at the bottom of the tank.

Solution:

Refer Fig.

Let h_1 = Height of free surface or water from A-B.

Pressure at A = Pressure at B

$$w_1 h_1 = w_2 h_2$$

or

$$h_1 S_1 = h_2 S_2$$

$$h_1 = \frac{h_2 S_2}{S_1} = \frac{0.40 \times 1.9}{1} = 0.76 \text{ m}$$

Height of free surface above the bottom of the tank, $h = 0.50 + 0.76$

$$h = 1.26 \text{ m}$$

Pressure intensity at the bottom of the tank, $p = wh$

$$= 9810 \times 1.26 = 12360.6 \text{ N/m}^2. \text{ ANS}$$

Example: The pressure of water in a pipeline was measured by means of a simple manometer containing mercury. The reading of the manometer is shown in Fig. Determine the absolute pressure in the pipeline if the atmospheric pressure is 100 kN/m^2 .

Solution:

Let h_A = Pressure head in terms of water at A.

Taking X-X as datum line.

$$\begin{aligned} \text{Pressure head in the left limb} &= h_A + (0.20 + 0.08)S_1 \\ &= h_A + 0.28 \times S_1 \end{aligned}$$

$$\text{Pressure limb in the right limb} = 0.08 S_2$$

Equating the two pressure heads, we get

$$h_A + 0.28 S_1 = 0.08 S_2$$

$$h_A = 0.08 S_2 - 0.28 S_1 = 0.08 \times 13.6 - 0.28 \times 1 = 0.808 \text{ m of water}$$

$$\text{Pressure in pipe, } p_A = \rho h_A = 9810 \times 0.808 = 7926 \text{ kN/m}^2$$

$$\begin{aligned} \text{Absolute pressure in pipe, } p_{\text{abs}} &= p_{\text{atm}} + p_{\text{gauge}} \\ &= 100 + 7.926 = 107.926 \text{ kN/m}^2 \end{aligned}$$

ANS.

Example: A fluid of specific gravity 0.82 is flowing in a pipe. A simple U-tube manometer is connected to the pipe. The centre of the pipe is 0.18 m below the level of mercury in the right limb. Determine the pressure of fluid in the pipe when the difference of mercury level in two limbs is 0.25 m.

Solution:

Let h_A = Pressure head in terms of water at A.

Taking X-X as datum line.

Pressure head in the left limb = $h_A + h_1S_1$

Pressure limb in the right limb = h_2S_2

Equating the two pressure heads, we get

$$h_A + h_1S_1 = h_2S_2$$

$$h_A = h_2S_2 - h_1S_1 = 0.25 \times 13.6 - 0.07 \times 0.82 = 3.34 \text{ m of water}$$

$$h_A = 3.34 \text{ m of water}$$

$$\text{Pressure in pipe, } p_A = \rho h_A = 9810 \times 3.34 = 32765.4 \text{ kN/m}^2$$

ANS.

Example: Fig. shows a single column manometer connected to a pipe containing oil of specific gravity 0.8. The ratio of area of the reservoir to that of the right limb is 100. Find the pressure in the pipe.

Solution:

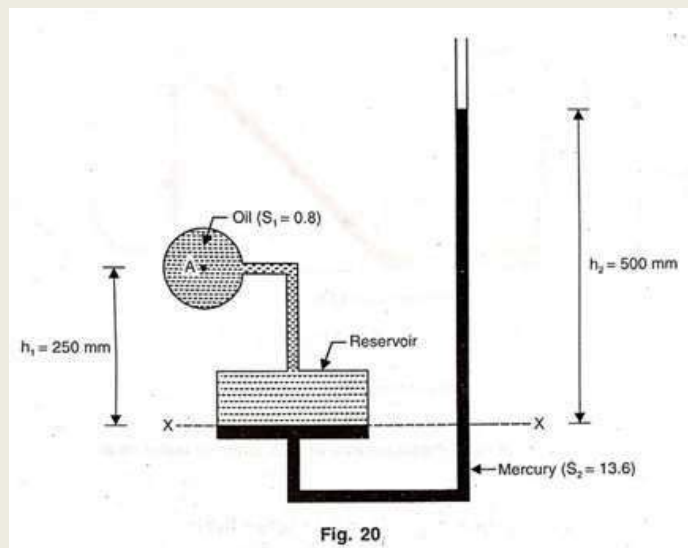

Let h_A = Pressure head at A in terms of head of water.

$$\frac{\text{Area of reservoir}}{\text{Area of right limb}} = \frac{A}{a} = 100$$

using the relation

$$h_A = \frac{a \times h_2}{A} (S_2 - S_1) + h_2 S_2 - h_1 S_1$$

$$h_A = \frac{500}{100} (13.6 - 0.8) + 500 \times 13.6 - 250 \times 0.8 = 6664$$

$$h_A = 6664 \text{ mm of water} = 6.664 \text{ m of water}$$

Pressure in the pipe, $p_A = \rho h_A$

$$p_A = 9810 \times 6.664 = 65373.84 \text{ N/m}^2$$

ANS.

DIFFERENTIAL MANOMETERS

Differential manometers are the devices used to measure the difference of pressures between two points in a pipe or in two different pipes.

A differential manometer consists of a U-tube made of glass. The two ends of the U-tube are connected to the two points (if necessary, through rubber tubings) whose difference of pressure is to be measured. U-tube contains heavy liquid.

Types of Differential Manometers. There are two common types of differential manometers :

1. U-tube differential manometer
2. Inverted U-tube differential manometer.

1). U-tube differential manometer. Fig.6 shows the U-tube differential manometer. Let the pressure at A is more than the pressure at B.

Case I. Fig. 6 (a) shows a U-tube differential manometer whose two ends are connected with two points A and B. These points A and B are at different levels.

Let h = Difference of the levels of the heavy liquid in the U-tube (also known as differential manometer reading) in terms of head of water

h_1 = Distance of centre of pipe A above the datum line X-X

h_2 = Distance of centre of pipe B from the heavy liquid level in the right limb

S_1 = Specific gravity of liquid in pipe A

S_2 = Specific gravity of liquid in pipe B

S = Specific gravity of heavy liquid

h_A = Pressure head at A

h_B = Pressure head at B.

Taking X-X as datum line.

Pressure head in the left limb = $h_A + h_1 S_1$

Pressure head in the right limb = $h_B + h_2 S_2 + hS$

Equating the two pressure heads, we get

$$h_A + h_1 S_1 = h_B + h_2 S_2 + hS$$

$$h_A - h_B = h_2 S_2 + hS - h_1 S_1$$

If $S_1 = S_2$ then,

$$h_A - h_B = h_2 S_1 + hS - h_1 S_1 = S_1 (h_2 - h_1) + hS$$

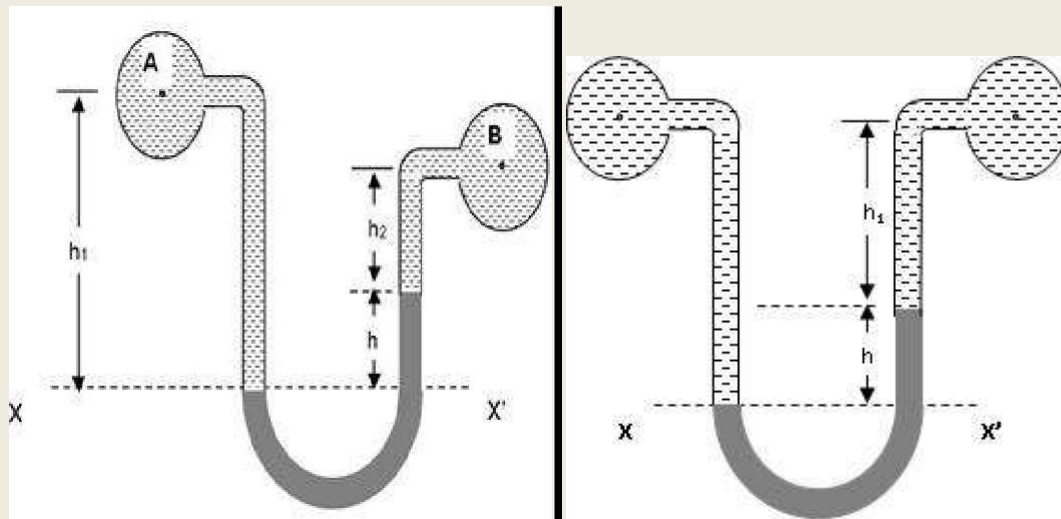

Two pipes at different level

(a)

Two pipe at same level

(b)

Fig 6

Case II. Fig.6 (b) shows two points A and B are at the same level.

Let h = Difference of the levels of the heavy liquid in the U-tube (also known as differential manometer reading)

h_1 = Distance of centre of pipe B or A from the heavy liquid level in the right limb.

S_1 = Specific gravity of liquid in pipe A

S_2 = Specific gravity of liquid in pipe B

S = Specific gravity of heavy liquid.

h_A = Pressure head at A in terms of head of water

h_B = Pressure head at B in terms of head of water.

Taking X-X as datum line. Pressure head in the left limb = $h_A + (h + h_1) S_1$

Pressure head in the right limb = $h_B + h_1 S_1 + hS$

Equating the two pressure heads, we get

$$h_A + (h + h_1) S_1 = h_B + h_1 S_2 + hS$$

$$h_A - h_B = h_1 S_2 + hS - (h + h_1) S_1$$

if $S_1 = S_2$ then,

$$h_A - h_B = h_1 S_1 + hS - hS_1 - h_1 S_1$$

or $h_A - h_B = h(S - S_1)$

2). Inverted U-tube Differential Manometer. It is used to measure difference of low pressures where accuracy is the major consideration. It consists of an inverted U-tube containing a light liquid. The two ends of the U-tube are connected to the two points whose difference of pressure is to be measured. Fig.7 shows an inverted U-tube differential manometer. Let the pressure at A is more than the pressure at B.

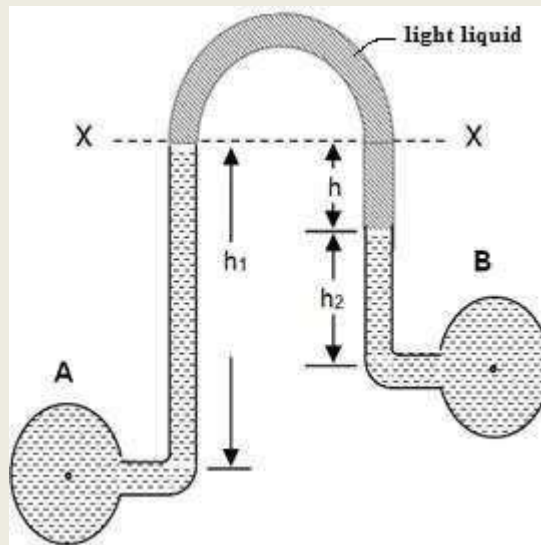

Inverted U-tube Differential Manometer

Fig 7

Let h_1 = Height of liquid in left limb below the datum line X-X

h = Difference in the levels of the light liquids in the U-tube (Differential manometer reading)

h_2 = Distance of centre of pipe B from the light liquid level in the right limb

S_1 = Specific gravity of liquid in pipe A

S_2 = Specific gravity of liquid in pipe B

S = specific gravity of light liquid

h_A = pressure head at A in terms of head of water

h_B = pressure head at B in terms of head of water

Taking X-X as datum line.

Pressure head in the left limb = $h_A - h_1 S_1$

Pressure head in the right limb = $h_B - h_2 S_2 - hS$

Equating the two pressure heads, we get

$$h_A - h_1 S_1 = h_B - h_2 S_2 - hS$$

$$h_A - h_B = h_1 S_1 - h_2 S_2 - hS$$

Example: Determine the difference of pressure between two pipes A and B. The pipe A contains a liquid of specific gravity 1.6 and pipe b carries another liquid having specific gravity 0.8. The arrangement of pipes has been shown in Fig. 24. Mercury is used as the manometric liquid.

Example: A differential manometer is used to measure the difference of pressure of oil contained in two pipes at the same level. If the deflection of manometer liquid which is mercury, be 100 mm then determine the difference of pressure of oil in the two pipes. Take specific gravity of oil = 0.8.

SOLUTION.

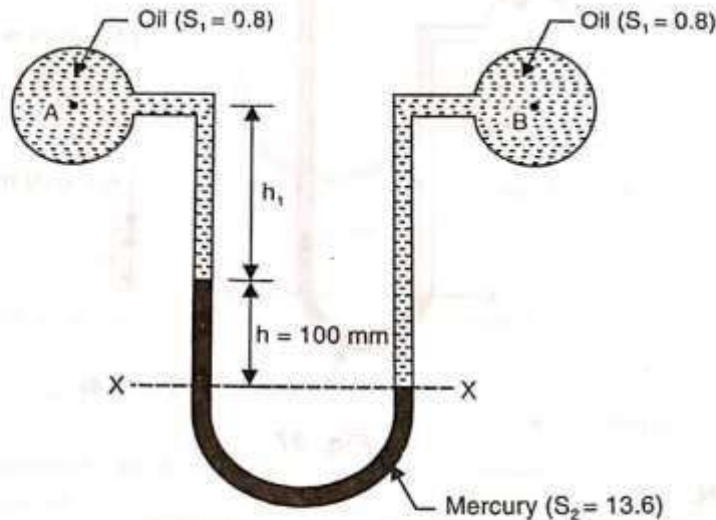

Fig. 26

Let pressure in pipe B is greater than pressure in pipe A (Fig. 26).

h_A = Pressure head at A in terms of head of water

h_B = Pressure head at B in terms of head of water.

Taking X-X as datum line.

Pressure head in the left limb = $h_A + h_1 S_1 + h S$

Pressure head in the right limb = $h_B + (h_1 + h) S_1$

Equating the two pressure heads, we get

$$h_A + h_1 S_1 + h S = h_B + (h_1 + h) S_1$$

$$h_A - h_B = h_1 S_1 + h S_1 - h_1 S_1 - h S$$

$$h_A - h_B = h (S_1 - S)$$

$$= 100 (0.8 - 13.6) = -1280 \text{ mm of water}$$

-ve sign indicates that pressure in the B is more than pressure in the pipe A.

$$\therefore h_B - h_A = 1280 \text{ mm of water} = 1.28 \text{ m of water}$$

$$\begin{aligned} \text{Pressure difference in two pipes} &= p_B - p_A = w (h_B - h_A) \\ &= 9810 (1.28) = 12556.8 \text{ N/m}^2 \end{aligned}$$

ANS

Example: Fig. shows a differential manometer connected at two points A and B. At A air pressure is 1 bar. Find the absolute pressure at B.

ADVANTAGES AND LIMITATIONS OF MANOMETERS

Advantages of Manometers.

- (i) Relatively inexpensive and easy to fabricate
- (ii) Good accuracy and high sensitivity
- (iii) Requires little maintenance
- (iv) Particularly suitable for low pressures and low differential pressures
- (v) Not affected by vibration
- (vi) Sensitivity can be easily changed by changing the quantity of manometric liquid in the manometer.

Limitations of Manometers.

- (i) Usually bulky and large in size
- (ii) Readings of the manometers are affected by changes in gravity, temperature and altitude
- (iii) A capillary effect is created due to surface tension of manometric liquid
- (iv) For better accuracy meniscus has to be measured by accurate means

- (v) Being fragile, get broken easily.

MANOMETRIC LIQUIDS

The U-tube manometer contains a liquid called manometric liquid or balancing liquid. The specific gravity of the manometric liquid is greater than the specific gravity of the liquid whose pressure is to be measured. But in case of inverted U-tube differential manometer, the specific gravity of manometric liquid is less than the specific gravity of the liquid whose pressure is to be measured. Commonly used manometric liquids are : Mercury (specific gravity 13.6), Carbon tetrachloride (specific gravity 1.61) and Acetylene tetrabromide (specific gravity 2.59).

Desirable Characteristics of a Manometric Liquid. Some of the desirable characteristics of a manometric liquid are :

- (i) low vapour pressure
- (ii) low co-efficient of thermal expansion
- (iii) low viscosity
- (iv) negligibe surface tension and capillary effects
- (v) non-corrosive, non-poisonous and non-sticky.

The choice of a particular manometric liquid depends upon the pressure range and the nature of the liquid whose pressure is to be measured. For high pressure ranges mercury is used as manometric Mercury does not evaporate easily (low vapour pressure) and forms a sharp meniscus.

For low pressure ranges, carbon tetrachloride or acetylene tetrabromide are used.

MECHANICAL GAUGES

Mechanical gauges are the devices used for measuring the pressure by balancing the column of fluid by the spring or dead weight. These are generally used for measuring high pressures such as in steam boilers, water mains and where high accuracy is not required.

Mechanical gauges use different forms of elastic systems such as tubes, diaphragms or bellows etc. to measure the pressure. These elements (elastic systems) deflect under the action of the applied pressure. Since these elements are deflected within the elastic limits only, therefore these gauges are sometimes called **elastic gauges**. Some of the important mechanical gauges are :

1. Bourdon's tube pressure gauge
2. Diaphragm pressure gauge
3. Bellow pressure gauge
4. Dead-weight pressure gauge.

BOURDON'S TUBE PRESSURE GAUGE

It is used to measure high as well as vacuum pressure.

Construction.

(i) It consists of a circular spring tube A, called Bourdon's tube (Fig. 32). The tube is made of bronze or nickel steel. Bronze tube is generally used for low pressures and nickel steel tube is used for high pressures. The tube is oval (i.e. egg shaped) in cross-section.

(ii) One end of the Bourdon's tube is closed and connected to link L. The other end of the tube is placed in a vertical tube B.

(iii) The link L connects the closed end of the Bourdon's tube to a toothed sector C which is hinged at O.

(iv) The toothed sector C gears with a pinion D which is mounted on a central spindle carrying a pointer P. The pointer P moves on a dial graduated in a suitable scale.

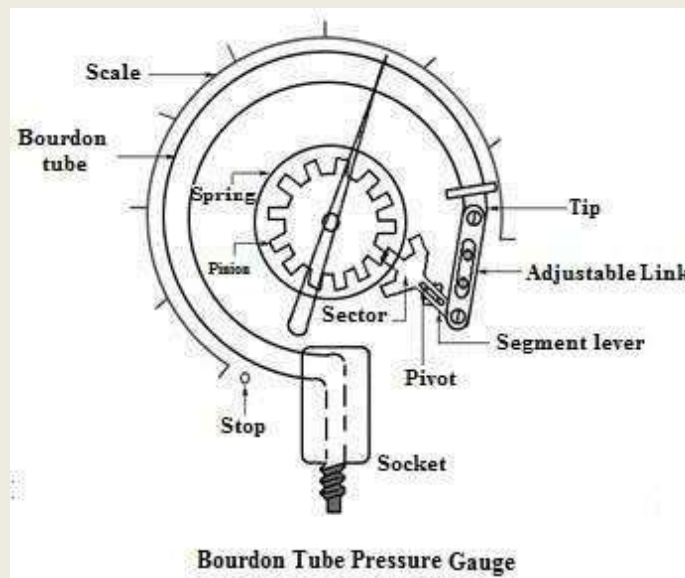

Fig. 8

Working. The pressure gauge is connected to the vessel containing fluid under pressure. When the fluid enters the tube under pressure, the oval cross-section of the tube tries to become circular. Thus, the tube straightens out slightly. This moves the free end of the tube outwards. This small outward movement of the tube is transmitted to a pointer through pinion arrangement. The pointer moves on a dial.

DIAPHRAGM PRESSURE GAUGE

It is used to measure gauge as well as vacuum pressures. It consists of a corrugated diaphragm (instead of Bourdon's tube) as shown in Fig. 9

The gauge is connected to the fluid (whose pressure is required to be found out) at A. The fluid under pressure causes some elastic deformation of the diaphragm. With the help of some pinion arrangement, the elastic deformation of the diaphragm rotates the pointer. This pointer moves on a dial graduated in pressure units.

Diaphragm pressure gauge is used to measure comparatively low pressures

DEAD WEIGHT PRESSURE GAUGE

It is the most accurate pressure gauge which is used for the calibration of the other pressure gauges in a laboratory.

It consists of a piston and cylinder of a known area. One end of the tube containing fluid (generally water) is connected to the cylinder. A pressure gauge to be calibrated is fitted to the other end of the tube. Dead weight is placed on the top of piston.

Let W = weight placed on the piston

A = cross-sectional area of the piston

Then, intensity of pressure, $p = W/A$

This pressure is transmitted to the pressure gauge to be calibrated. The pointer of the pressure gauge moves and takes up a steady position on the dial. The position of the pointer is marked as 'p'. In this way, by loading the piston by weights (loads) of other magnitudes, other intensities of pressures are marked on the dial.

Theoretical Questions

1. Distinguish between gauge pressure and absolute pressure.
2. What do you mean by vacuum pressure ?
3. Can you measure pressure of a gas by a piezometer ? What are the limitations of piezometer ?
[Hints. Pressure of gas cannot be measured by a piezometer]
4. What is the difference between pressure gauge and manometers?
5. State the different principles of measurement of pressures.
6. What is a simple manometer ?
7. What is the relationship between various types of pressures ?

8. Why piezometers cannot measure large pressures ?
9. Name the various types of manometers.
10. Distinguish between piezometer and pressure gauge. When and where are they used ?
11. Write short note on
 - (a) Bourdon's tube pressure gauge
 - (b) Micromanometer.
12. What are differential manometers ?
13. Explain absolute, gauge and vacuum pressure.
14. State the principle of pressure measurement by a manometer. Explain the difference between a simple and differential manometer.
15. Explain with the help of a neat sketch in brief the working of a Bourdon's tube pressure gauge.
16. What is a manometer ? Describe with a neat sketch a U-tube manometer.
17. What is the difference between U-tube and inverted U-tube differential manometers? Where are they used ?
18. Distinguish between manometers and mechanical gauges. What are different types of mechanical pressure gauges ?
19. How do you measure gauge pressure ?
20. How is the negative pressure measured with the help of a U-tube?
21. Can a piezometer be used for measuring pressure in the pipe through which a fluid is flowing ?
22. How the sensitivity of a single column manometer be increased ?
23. Mention some of the desirable characteristics of manometric liquids.
24. Write short note on
 - (i) Dead weight pressure gauge
 - (ii) Diaphragm pressure gauge
 - (iii) Bourdon's tube pressure gauge.

Numerical Problems

1. The barometric pressure at sea level is 760 mm of mercury and that on a mountain is 735 mm of mercury. If the specific weight of air is assumed constant as 12 N/m^3 , what is the elevation of the mountain top?
2. The atmospheric pressure at a place is found to be equal to 0.76 m of mercury. Find the absolute pressure in N/m^2 when
 - (i) gauge pressure is 2.54 m of water
 - (ii) vacuum pressure is 24 kN/m^2 .

[ANS. $1.263 \times 10^5 \text{ N/m}^2$, $0.7739 \times 10^5 \text{ N/m}^2$]

3) A U-tube manometer containing mercury has its left limb attached to a pipe containing water under certain pressure. The surface of mercury in the open right limb is measured to be equal to 50 mm below the centre line of the pipe and the difference of mercury level in the two limbs is found to be equal to 75 mm. Find the pressure of water in the pipe if specific gravity of mercury 13.6. **[ANS. 8.78 KN/m²]**

4. A U-tube manometer is used to measure the pressure of oil of specific gravity 0.85 flowing in a pipeline. Its left limb is connected to the pipe and the right limb is open to the atmosphere. The centre of the pipe is 100 mm below the level of mercury in the right limb. If the difference of mercury level in the two limbs is 160 mm, determine the absolute pressure of the oil in the pipe. Take atmospheric pressure as 100 kN/m². **[ANS. 120.84 kN/m²]**

5. A simple manometer is used to measure the pressure of oil (Specific gravity = 0.9) flowing in a pipeline. Its right limb is open to the atmosphere and left limb is connected to the pipe. The centre of the pipe is 80 mm below the level of mercury in the right limb. If the difference of mercury levels in the two limbs is 130 mm, find the pressure of oil in the pipe. **[ANS. 16902.63 N/m²]**

6. Fig. 35 shows a manometer connected to a pipeline, containing oil of specific gravity 0.8. Find the pressure of oil in the pipe.

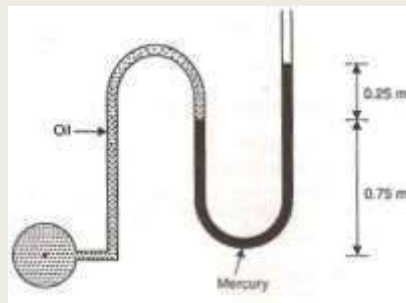

7. One limb of a U-tube containing mercury is attached to a pipe carrying water under pressure of 200 kN/m². If the mercury level rises up in the free limb by 'h' above its level in the other limb, find the value of 'h' if the centre line of pipe is 1.87 m above the top level of mercury in the free limb.

[ANS. 1.761 m]

8. Fig. 36 shows a differential manometer connected at two points A and B. At A air pressure is 100 kPa. Find the absolute pressure at B. **[ANS. 84.36 kPa]**

Chapter - 5

FUNDAMENTALS OF FLUID FLOW

INTRODUCTION

When fluid is in rest position, the results theoretically and practically holds good, but, this is not so with fluid in motion. For fluids in rest positions, specific weight is the important property, but when the fluid is in motion, various other fluid properties becomes significant. Due to this reason, the nature of flow of real fluid is very complex. But for analysis the fluid is assumed to be incompressible and non-viscous. In this chapter, we shall study the liquid flow and forces causing the same.

TYPES OF FLOW

Various types of fluid flow are as the following:

- i.* Steady flow
- ii.* Unsteady flow
- iii.* Uniform flow
- iv.* Non-uniform flow
- v.* Laminar flow
- vi.* Turbulent flow

1. **STEADY FLOW:** The type of flow in which fluid characteristics like velocity, pressure, density etc. at a point do not change with time is called steady flow. e.g. flow through a prismatic and non prismatic conduit at a constant flow rate.
2. **UNSTEADY FLOW:** The type of flow in which fluid characteristics like velocity, pressure, density etc. at a point change with time is called unsteady flow. e.g. flow in a pipe whose wall is being opened or closed gradually.
3. **UNIFORM FLOW:** The type of flow in which the velocity at any given time does not change with respect to space is called uniform flow. e.g. flow through a straight pipe of constant diameter will be uniform.
4. **NON UNIFORM FLOW:** The type of flow in which the velocity at any given time change with respect to space is called non uniform flow. e.g. flow around a uniform diameter pipe bend or a canal bend will be non uniform.
5. **LAMINAR FLOW:** The type of flow in which the fluid particle move in layers and do not cross the path of other particles. Such flow of fluids is called Laminar Flow. e.g. the flow through a capillary tube and ground water flow.

6. **TURBULENT FLOW:** The type of flow in which the fluid particles move in a zig-zag way i.e. particles do not move in layers and cross the path of other particles is called turbulent flow.
e.g. high velocity flow in a conduit of long size will be turbulent.

RATE OF FLOW OR DISCHARGE

The quantity of fluid per unit time across any section is known as discharge or rate of flow. It is denoted by Q and expressed in SI units as m^3/s if value is taken as quantity of fluid. Fluid also may be measured in terms of mass or weight of fluid. In that case units would be kg/s or n/s respectively.

Let A = Cross-sectional area of the pipe

V = Average velocity of liquid

Then Discharge Q = area \times average velocity

$$Q = A.V$$

Units $Q = \text{m}^2 \cdot \text{m}/\text{s} = \text{m}^3/\text{s}$ (cumecs)

CONTINUITY EQUATION

The continuity equation describes the transport of some quantities like fluid or gas. The equation explains how a fluid conserves mass in its motion. Many physical phenomena like energy, mass, momentum, natural quantities and electric charge are conserved using the continuity equations.

This equation provides very useful information about the flow of fluids and its behaviour during its flow in a pipe or hose. The hose, a flexible tube, whose diameter decreases along its length has a direct consequence. The volume of water flowing through the hose must be equal to the flow rate on the other end. The flow rate formula

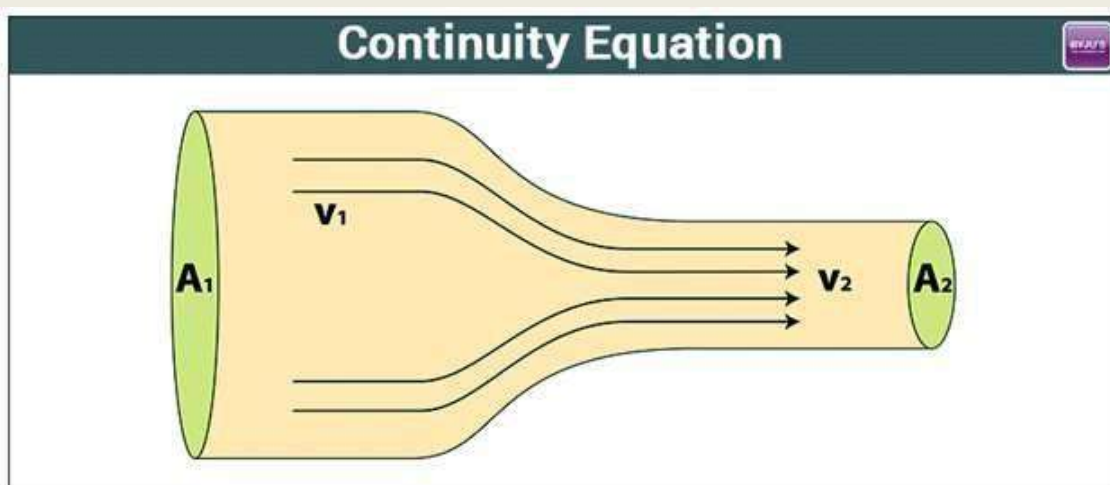

The Equation of Continuity and can be expressed as

Let A_1 = Cross-sectional area of pipe at section 1-1,

v_1 = velocity of flow at section 1-1,

ρ_1 = Density of liquid at section 1-1,

A_2 = Cross-sectional area of pipe at section 2-2,

v_2 = velocity of flow at section 2-2,

ρ_2 = Density of liquid at section 2-2.

Now, Mass of liquid flowing per unit time at section 1-1 = $\rho_1 A_1 v_1$

Mass of liquid flowing per unit time at section 2-2 = $\rho_2 A_2 v_2$

According to law of conservation of mass,

$$\rho_1 A_1 v_1 = \rho_2 A_2 v_2$$

The above equation is called continuity equation and is applicable to both compressible and incompressible.

$$\rho_1 = \rho_2$$

$$A_1 v_1 = A_2 v_2$$

TYPES OF HYRAULIC ENERGIES

There are three types of hydraulic energies:

1. Potential energy or Elevation energy
2. Kinetic energy or velocity energy
3. Pressure energy or flow energy

1) **Potential or elevation energy:** The energy possessed by fluid body by virtue of its position or location is referred as potential energy or elevation energy. It is denoted by z . If a liquid particle is z meters about the horizontal datum so the potential energy in terms of head is z m of liquid. This is also known as potential head.

Datum level is an imaginary level which is arbitrarily chosen.

2) **Kinetic energy or velocity energy :** The energy possessed by fluid body by virtue of its motion or velocity is referred as kinetic energy or velocity energy. If velocity of flowing fluid is V m/s, then the kinetic energy or kinetic head is given by $V^2/2g$.

3) **Pressure energy or flow energy:** The energy possessed by a fluid body by virtue of the existing pressure is called potential energy. If a fluid particle is under a pressure of p N/m², then the pressure energy or pressure head will be given by p/w .

Total Head of Liquid:

The total head of a particle of a liquid at any instant is the sum of its potential head, pressure head and velocity head.

Potential head:

The height of the liquid which is responsible for potential energy is commonly known as potential head and is denoted by Z , as Z metre of liquid.

i.e. Potential head = Z metre of liquid

Pressure head:

The pressure energy per unit weight of fluid is called pressure head and is denoted by $\frac{p}{w}$, as p/w metre of liquid.

i.e. Pressure head = $\frac{p}{w}$ metre of liquid

Velocity head:

The kinetic energy per unit weight of fluid is known as velocity head or kinetic head denotes by $V^2/2g$.

i.e. velocity head = $\frac{v^2}{2g}$ metre of liquid

Mathematically :

Total head $H = z + \frac{p}{w} + \frac{v^2}{2g}$ metre of liquid.

BERNOULLI'S THEOREM :

It states that total energy (potential energy, kinetic energy and pressure energy) of an incompressible, non-viscous fluid in steady flow through a pipe remains constant throughout the flow, provided there is no source or sink of the fluid along the length of pipe.

$$\text{Pressure energy} = \frac{p}{w}$$

$$\text{Kinetic energy} = \frac{v^2}{2g}$$

And Datum energy = Z

Therefore, mathematically, Bernoulli's theorem is written as

$$z + \frac{p}{w} + \frac{v^2}{2g} = \text{Constant}$$

This theorem was put forward in 1738 by Daniell Bernoulli who was a Swiss Engineer. It is a form of the well known principle of conservation of energy.

Assumptions: The following are the assumptions made in the derivation of Bernoulli's equation:

1. The fluid is ideal i.e. viscosity is zero.
2. The flow is steady.
3. The flow is incompressible.
4. The flow is irrotational.

SOLVED PROBLEMS

1. The diameter of a pipe changes from 200mm at a section 5m above datum to 50mm at a section 3m above datum. The pressure of water at first section is 500kPa. If the velocity of the flow at the first section is 1m/s, determine the intensity of pressure at the second section.

SOL: Given,

- $d_1 = 200\text{mm} = 0.2\text{m}$,
- $z_1 = 5\text{m}$,
- $d_2 = 50\text{mm} = 0.05\text{m}$,
- $z_2 = 3\text{m}$,
- $P = 500\text{kPa} = 500\text{KN/m}^2$ and
- $v_1 = 1\text{m/s}$.

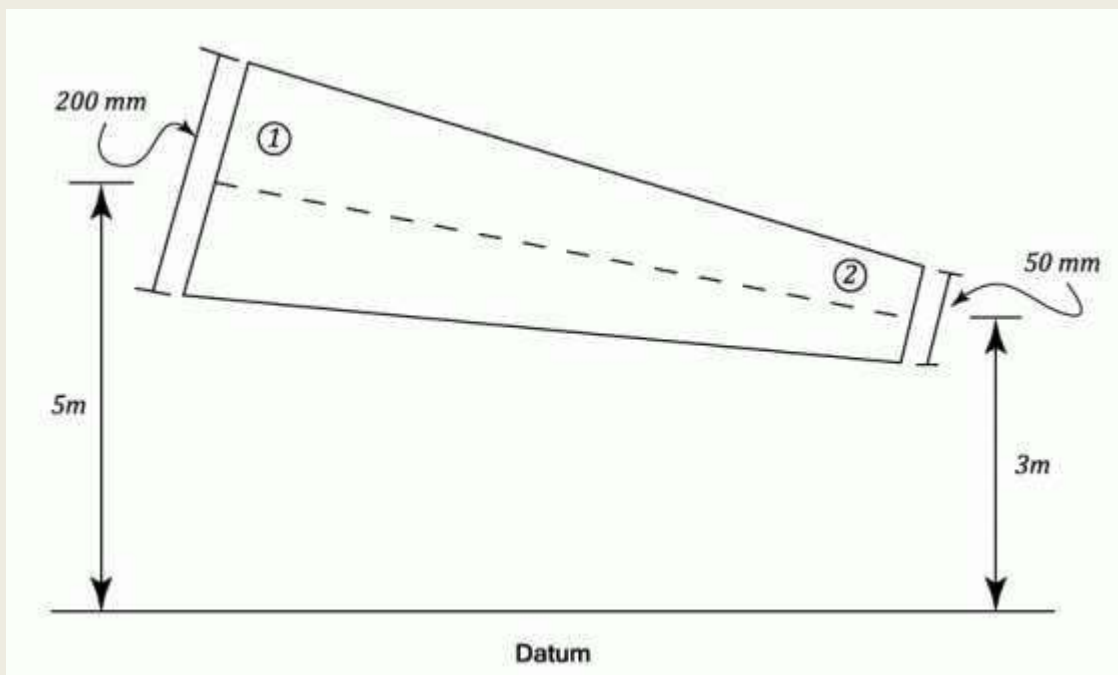

Let,

- v_2 = Velocity of flow at section (2), and
- P_2 = Pressure at section (2).

We know that area of the pipe at section (1),

and area of pipe at section (2),

$$a_2 = \frac{\pi}{4} \times d_2^2 = \frac{\pi}{4} \times 0.05^2 = 1.964 \times 10^{-3} m^2$$

Since the discharge through the pipe is continuous, therefore

$$a_1 \cdot v_1 = a_2 \cdot v_2$$

$$\Rightarrow v_2 = \frac{a_1 \cdot v_1}{a_2} = \frac{31.42 \times 10^{-3} \times 1}{1.964 \times 10^{-3}} = 16 m/s$$

Applying Bernoulli's equation for both the ends of the pipe,

$$z_1 + \frac{v_1^2}{2g} + \frac{P_1}{\rho g} = z_2 + \frac{v_2^2}{2g} + \frac{P_2}{\rho g}$$

$$\Rightarrow 5 + \frac{1^2}{2 \times 9.81} + \frac{500}{9.81} = 3 + \frac{16^2}{2 \times 9.81} + \frac{P_2}{9.81}$$

$$\Rightarrow 5 + 0.05 + 51 = 3 + 13.05 + \frac{P_2}{9.81}$$

$$\therefore P_2 = 392.4 kN/m^2 = 392.4 kPa$$

Solution

The intensity of pressure at the second section = 392.4 kPa

2. A pipe 300m long has a slope of 1 in 100 and tapers from 1m diameter at the higher end to 0.5m at the lower end. The quantity of water flowing is 900 liters/second. If the pressure at the higher end is 70kPa, find the pressure at the lower end.

Sol: Given,

- $l = 300m$,
- Slope = 1 in 100
- $d_1 = 0.5m$
- $d_2 = 1m$ and

- $Q = 900 \text{ liters/s} = 0.9 \text{ m}^3/\text{s}$
- $P_2 = 70 \text{ kPa} = 70 \text{ kN/m}^2$
-

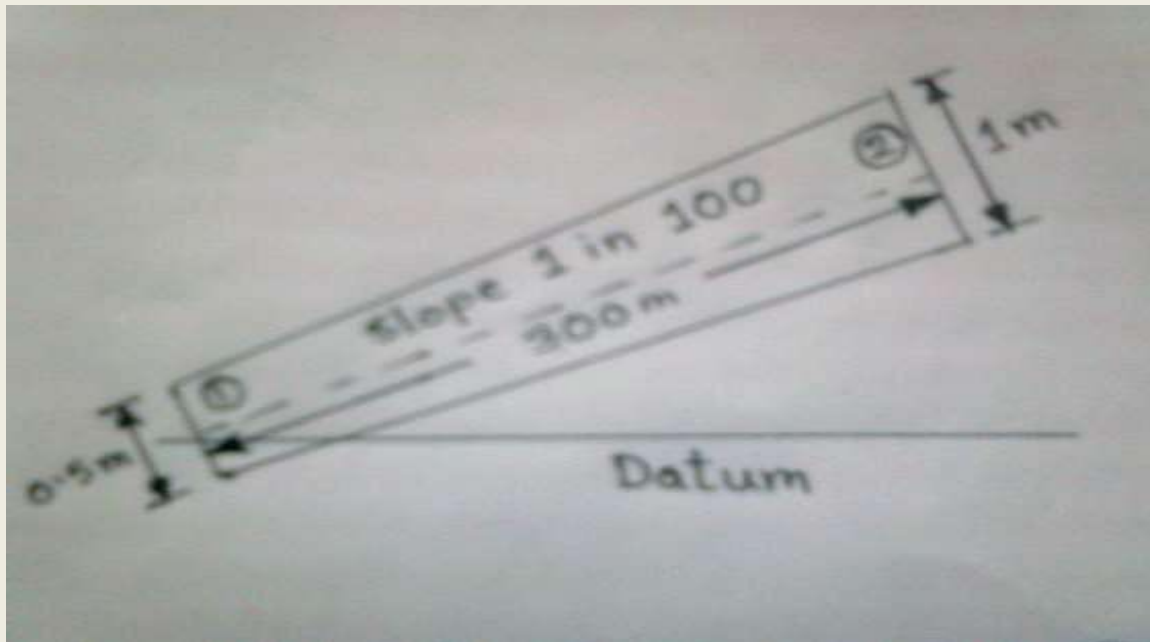

Let,

P_1 = Pressure at section (1)

We know that area of pipe at section (1),

$$a_1 = \frac{\pi}{4} \times (d_1)^2 = \frac{\pi}{4} \times 0.5^2 = 0.1964 \text{ m}^2$$

and area at section (2),

$$a_2 = \frac{\pi}{4} \times (d_2)^2 = \frac{\pi}{4} \times 1^2 = 0.7854 \text{ m}^2$$

First of all, let us assume the datum line to coincide with the centre of the pipe as section (1) as shown in figure. Thus, $z_1 = 0$. Now from the geometry of the pipe, we find that the height of the higher end from the datum line,

$$z_2 = \frac{1}{100} \times 300 = 3 \text{ m}$$

We also know that velocity of water at section (1),

and velocity of water at section (2),

$$v_2 = \frac{Q}{a_2} = \frac{0.9}{0.7854} = 1.15 \text{ m/s}$$

Now using Bernoulli's equation for both ends of the pipe,

$$z_1 + \frac{v_1^2}{2g} + \frac{P_1}{\rho g} = z_2 + \frac{v_2^2}{2g} + \frac{P_2}{\rho g}$$

$$\Rightarrow 0 + \frac{4.58^2}{2 \times 9.81} + \frac{P_1}{9.81} = 3 + \frac{1.15^2}{2 \times 9.81} + \frac{70}{9.81}$$

$$\Rightarrow 0 + 1.07 + \frac{P_1}{9.81} = 3 + 0.07 + 7.14$$

$$\therefore P_1 = 89.7 \text{ kN/m}^2 = 89.7 \text{ kPa}$$

Solution

Pressure at the lower end = 89.7 kPa

3. Water is flowing through a non-uniform pipe gradually tapering from 0.15 m diameter to 0.08 m diameter. If the average velocity of water at section 0.15 m diameter is found to be equal to 1.5 m/s, find out the discharge in litre per second and also the velocity of flow at 0.08 m diameter section ?

Sol: Given

$$\begin{aligned} D_1 &= 0.15 \text{ m,} \\ D_2 &= 0.08 \text{ m,} \\ v_1 &= 1.5 \text{ m/s} \\ Q &= ? \quad \text{and} \quad v_2 = ? \end{aligned}$$

We have, $A_1 = \frac{\pi}{4} D_1^2 = \frac{\pi}{4} (0.15)^2 = 0.01767 \text{ m}^2$

And $A_2 = \frac{\pi}{4} D_2^2 = \frac{\pi}{4} (0.08)^2 = 0.005 \text{ m}^2$

$$\begin{aligned} \text{Discharge. } Q &= A_1 v_1 \\ &= 0.01767 \times 1.5 = 0.0265 \text{ m}^3/\text{s} \end{aligned}$$

Or $Q = 26.5 \text{ L/s (Ans.)}$

From the equation of continuity,

$$A_1 v_1 = A_2 v_2$$

$$v_2 = A_1 v_1 / A_2 = \frac{0.01767}{0.005} \times 1.5$$

$$= 5.3 \text{ m/s}$$

4. The rate of flow through a pipe A-B is 500 L/s. The diameter at the end is 20 cm and velocity at the end B is 3 m/s. Determine the velocity at end A and diameter of pipe at the end B.

Sol: Given $Q = 500 \text{ lit/sec} = \frac{500}{1000} = 0.5 \text{ m}^3/\text{s}$

$$D_A = 20 \text{ cm } 0.20 \text{ m}$$

$$V_B = 3 \text{ m/s}$$

As we know that

$$Q = A_A V_A$$

$$A_A = \frac{\pi}{4} \times (D_A)^2$$

$$= \frac{\pi}{4} \times (0.20)^2 = 0.03142 \text{ m}^2$$

Now $Q = A_A V_A$

$$V_A = \frac{Q}{A_A} = \frac{0.5}{0.03142} = 15.9 \text{ m/s}$$

$$A_A V_A = A_B V_B$$

$$A_B = A_A V_A / V_B$$

$$= 0.03142 \times 15.9 / 3$$

$$= 0.1667 \text{ m}^2$$

$$\frac{\pi}{4} \times (D_B)^2 = 0.1667$$

$$D_B = 0.460 \text{ m}$$

$$D_B = 460 \text{ mm}$$

5. In a pipe of 100 mm diameter water is flowing with a mean velocity of 3 m/s and a gauge pressure of 300 KN/m^2 . Determine the total head, if the pipe is 10 m above the datum line. Neglect friction.

SOL Given

$$\text{Dia of pipe, } d = 100 \text{ mm} = 0.10 \text{ m}$$

Velocity of flow , $v = 3\text{m/s}$
Datum head , $z = 10\text{ m}$
Gauge pressure , $p = 300\text{ KN/m}^2$
Specific weight of water, $w = 9.81\text{ KN/m}^3$

As we know that , total head H is given by

$$H = z + \frac{p}{w} + \frac{v^2}{2g}$$
$$= 10 + \frac{300}{9.81} + \frac{3^2}{2 \times 9.81}$$

= 41.04 m of water.

IMPORTANT QUESTIONS FOR PRACTICE

- Distinguish between the following :
 - Steady flow or unsteady flow
 - Laminar and turbulent flow
 - Uniform and non-uniform flow.
- State and prove continuity equation.
- State Bernoulli's theorem and give its assumptions.
- Explain the different types of hydraulic energy.
- Explain the different types of head.
- What do you understand by rate of flow ? What is its SI units.
- The diameters of a pipe at sections 1-1 and 2-2 are 300 mm and 500 mm respectively. If the velocity of water flowing through the pipe at section 1-1 is 5 M/s, find
 - Discharge through the pipe, and
 - Velocity of water at section 2-2. ($Q=0.3534\text{m}^3/\text{s}$, $V_2=1.80\text{m/s}$)
- The water flowing through a pipe having diameters 40 cm and 25 cm at section A and B respectively. The rate of flow through pipe is 50 litres per sec. The section A is 8 m above datum and section B is 6 m above datum. If pressure at section A is 45 N/cm^2 . Find the intensity of pressure at B. (46.916 N/cm^2).

Chapter - 6

Venturimeter

Venturimeter

Venturimeter is a practical application of Bernoulli's equation. A venturimeter is a device used for measuring discharge of a fluid flowing through a pipe.

Principle: Working principle of venturimeter is based on Bernoulli's equation.

Types of venturimeter

1. Horizontal Venturimeter
2. Vertical Venturimeter
3. Inclined Venturimeter

A short converging part (with slope of the converging sides as 1 in 4 or in 5)

Throat

(iii) Diverging part (Length of the diverging part is 3 to 4 times the length of the converging part).

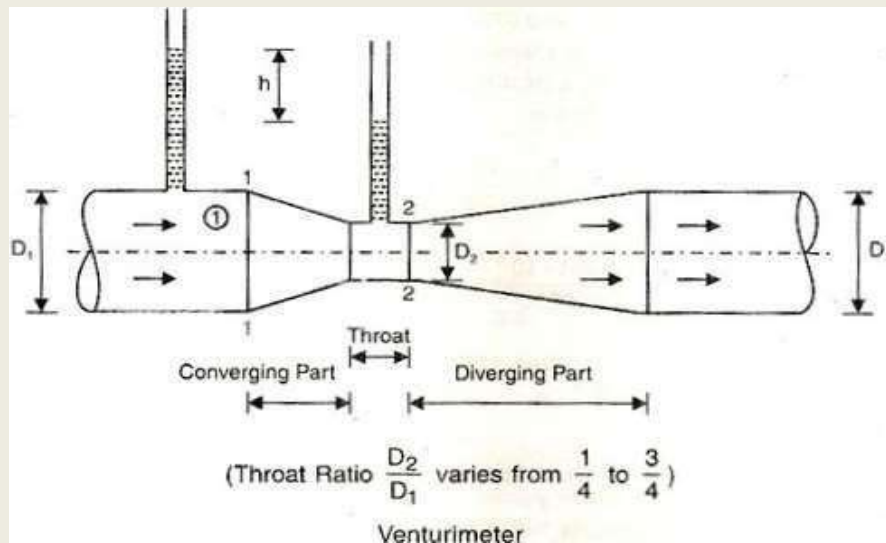

Let $D_1 =$ Diameter at inlet or at section 1-1

P_1 = Intensity of pressure at section 1-1

V_1 = Velocity of fluid at section 1-1

Z_1 = Datum head at section 1-1

$$A_1 = \text{Area at section 1-1} = \frac{\pi d_1^2}{4}$$

and D_2, p_2, Z_2, A_2 are the corresponding values at section 2-2,

Applying Bernoulli's equation at section 1-1 and 2-2 we get,

$$\frac{p_1}{w} + \frac{V_1^2}{2g} + Z_1 = \frac{p_2}{w} + \frac{v_2^2}{2g} + Z_2$$

As pipe is horizontal, hence $Z_1 = Z_2$

$$\frac{p_1}{w} + \frac{V_1^2}{2g} = \frac{p_2}{w} + \frac{v_2^2}{2g}$$

$$\text{or } \frac{p_1 - p_2}{w} = \frac{v_2^2}{2g} - \frac{V_1^2}{2g}$$

But $\frac{p_1 - p_2}{w}$ is the difference of pressure heads at sections 1-1 and 2-2 is equal to h

$$\text{i.e. } \frac{p_1 - p_2}{w} = h$$

Substituting this value of $\frac{p_1 - p_2}{w}$ in equatin (i) we get:

$$h = \frac{v_2^2}{2g} - \frac{V_1^2}{2g}$$

Applying continuity equation at section 1-1 and 2-2,

$$A_1V_1 = A_2V_2$$

or
$$V_1 = \frac{A_2V_2}{A_1}$$

Substituting this value of V_1 in equation (ii) we get:

$$h = \frac{V_2^2}{2g} - \frac{\left(\frac{A_2V_2}{A_1}\right)^2}{2g} = \frac{V_2^2}{2g} - \left[1 - \frac{A_2^2}{A_1^2}\right]$$

$$= \frac{V_2^2}{2g} - \left[\frac{A_1^2 - A_2^2}{A_1^2}\right]$$

or
$$V_2^2 = 2gh \left[\frac{A_1^2}{A_1^2 - A_2^2}\right]$$

$\therefore V_2 = \sqrt{2gh \left[\frac{A_1^2}{A_1^2 - A_2^2}\right]} = \frac{A_1\sqrt{2gh}}{\sqrt{A_1^2 - A_2^2}}$

\therefore Discharge, $Q = A_2V_2 = \frac{A_1A_2\sqrt{2gh}}{\sqrt{A_1^2 - A_2^2}} \dots (iii)$

or
$$Q = C\sqrt{h}$$

Let p_1 = Intensity of pressure at section 1-1

V_1 = Velocity of fluid at section 1-1

Z_1 = Datum head at section 1-1

A_1 = Area at section 1-1

and p_2, V_2, Z_2, A_2 are the corresponding values at section 2-2.

Applying Bernoulli's equation at sections 1-1 and 2-2, we get

$$\frac{p_1}{w} + \frac{V_1^2}{2g} + Z_1 = \frac{p_2}{w} + \frac{V_2^2}{2g} + Z_2$$

$$\left(\frac{p_1}{w} + Z_1\right) - \left(\frac{p_2}{w} + Z_2\right) = \frac{V_2^2}{2g} - \frac{V_1^2}{2g}$$

or
$$h = \frac{V_2^2}{2g} - \frac{V_1^2}{2g}$$

where $C = \text{Constant of venturimeter} = \frac{A_1 A_2 \sqrt{2ag}}{\sqrt{A_1^2 - A_2^2}}$

Equation (iii) gives the discharge under ideal conditions, and is called theoretical discharge. Actual discharge (Q_{act}) will be less than theoretical discharge.

$$Q_{\text{act}} = \frac{C_d A_1 A_2 \sqrt{2gh}}{\sqrt{A_1^2 - A_2^2}}$$

where $C_d = \text{Co-efficient of venturimeter (or Co-efficient of discharge)}$ and its value is less than 1 (varies between 0.96 and 0.98).

Due to variation of C_d , venturimeters are not suitable for every low velocities.

Value of 'h' given by differential U-tube manometer.

Let $y = \text{Difference in level of manometric liquid in the two limbs of U-tube manometer.}$

$S_m = \text{Specific gravity of manometric liquid.}$

S_p = Specific gravity of liquid flowing through pipe.

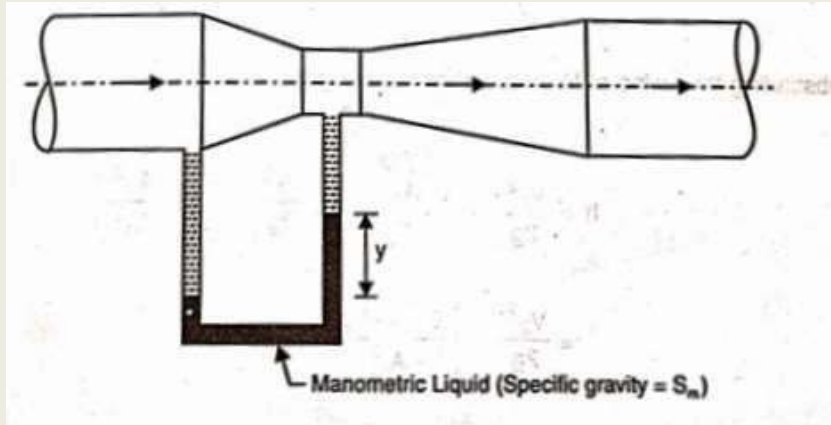

Case - I If $S_m > S_p$, then

$$h = y \left(\frac{S_m}{S_p} - 1 \right) \text{ meter of pipe liquid}$$

Case - II If $S_m < S_m$, then

$$h = y \left(1 - \frac{S_m}{S_p} \right) \text{ meter of pipe liquid}$$

2. Vertical and Inclined Venturimeters vertical or inclined venturimeters are used for

But for vertical and inclined venturimeters, $h = \left(\frac{P_1}{w} - \frac{P_2}{w} \right) = (Z_1 - Z_2)$

If U - tube differential manometer is used then

$$h = y \left(\frac{S_m}{S_p} - 1 \right) \dots \dots \dots \text{if } S_m > S_p \text{ metre of pipe liquid}$$

$$h = y \left(1 - \frac{S_m}{S_p} \right) \dots \dots \dots \text{if } S_m < S_m \text{ metre of pipe liquid}$$

ORIFICE METER (ORIFICE PLATE)

It is a simple device used for measuring the discharge of a fluid through a pipe. It is a cheaper device as compared to venturimeter. It 'also works on the same principle as that of venturimeter (i.e. working principle of orifice meter is based on Bernoulli's equation).

It consists of a flat circular plate having a central circular hole in it. This hole is called *orifice*. The diameter of the orifice varies from 0.4 to 0.8 times the diameter of pipe. But generally the diameter of the orifice is kept 0.5 times the diameter of pipe.

A differential manometer is fitted to the pipe (Fig. 19) at section 1 -1 (which is at a distance of 1.5 to 2 times the diameter of pipe) upstream side from the orifice plate and at section 2-2 (which is at a distance of about half the diameter of the orifice) downstream side from the orifice pla

Let p_1 = Intensity of pressure at section 1-1

V_1 = Velocity of fluid at section 1-1

Z_1 = Datum head at section 1-1

A_1 = Area at section 1-1

and p_2, V_2, Z_2, A_2 are the corresponding values at section 2-2.

Applying Bernoulli's equation at sections 1-1 and 2-2, we get

$$\frac{p_1}{w} + \frac{V_1^2}{2g} + Z_1 = \frac{p_2}{w} + \frac{V_2^2}{2g} + Z_2$$

$$\left(\frac{p_1}{w} + Z_1\right) - \left(\frac{p_2}{w} + Z_2\right) = \frac{V_2^2}{2g} - \frac{V_1^2}{2g}$$

or
$$h = \frac{V_2^2}{2g} - \frac{V_1^2}{2g}$$

where
$$h = \left(\frac{p_1}{w} + Z_1\right) - \left(\frac{p_2}{w} + Z_2\right) = \text{Differential head}$$

or
$$2gh = V_2^2 - V_1^2$$

or
$$V_2^2 = 2gh + V_1^2$$

or
$$V_2 = \sqrt{2gh + V_1^2} \quad \dots (i)$$

PITOT TUBE

Pitot tube is used to measure the velocity of flow at any point in a pipe or channel. It is a glass tube bent at right angles as shown in Fig. 20. The diameter of the tube is large enough to avoid the capillary effects. Pitot tube was invented by a French scientist Henri Pitot in 1730.

Principle. Pitot tube works on the principle that if the velocity of flow at any point becomes zero, the pressure there is increased due to the conversion of the kinetic energy into pressure energy.

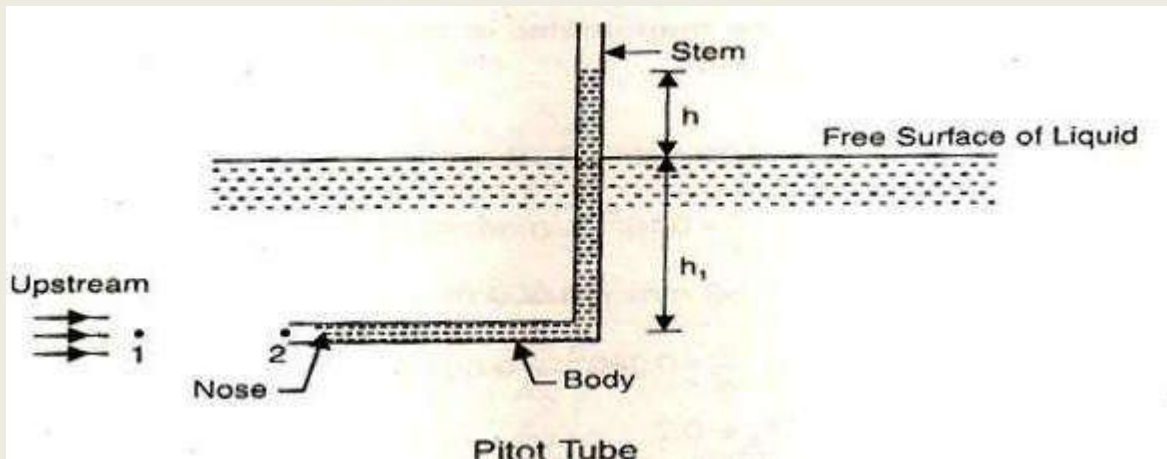

The lower end of the tube is placed in the direction of flow. The liquid rises up in the tube due to the conversion of kinetic energy into pressure energy. The velocity of flow is determined by measuring the rise of liquid in the tube.

PITOT-STATIC TUBE

It is used for the measuring the velocity of flow of a liquid flowing through a pipeline where the flow is due to the difference of pressure.

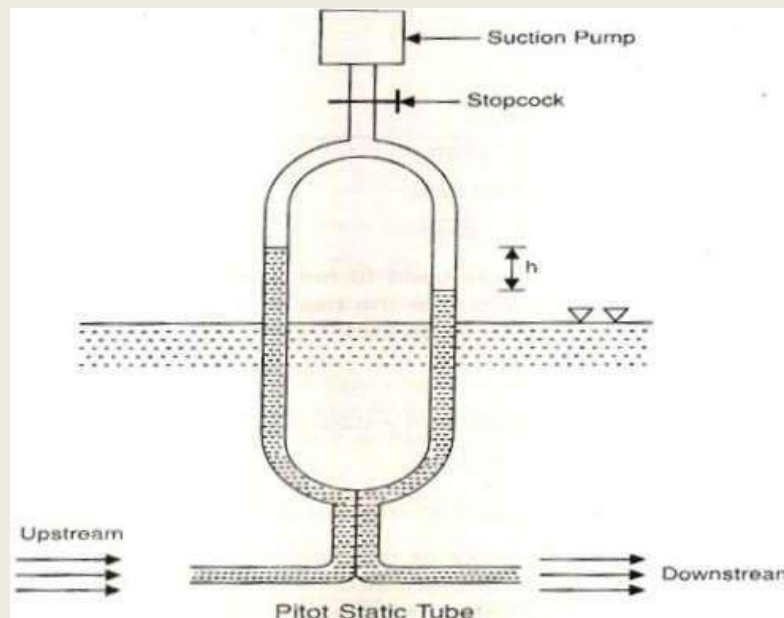

The open end or one tube is directed upstream and that of the other is direct downstream. The two tubes are joined at their upper ends to a simple tube which is connect a suction pump and provided with a stopcock. By opening the stopcock and drawing some of the air from the tubes, both the columns are raised to an equal amount since the press, their surfaces is reduced equally. The stopcock can then be closed and the difference night of columns can be read.

Let h = Difference of level of the liquid in the two legs of pitot-static tube. Theoretical velocity of flow, $V_{th} = \sqrt{2gh}$

Actual velocity of flow, $V_{ac} = C_v \times V_{th} = C_v \sqrt{2gh}$

where C_v = Co-efficient of velocity of the pitot-static tube

ORIFICE

An orifice is a small opening in the side or at the bottom of a tank through which the liquid flows. The top edge of the orifice is always below the free surface of liquid in the tank. **Functions of an orifice.**

An orifice is used to measure discharge of a liquid from a tank or a reservoir.

(ii) Orifice also helps in finding out the time required to empty a tank or time required to fall liquid from a particular level to a desired level.

CLASSIFICATION OF ORIFICES

The orifices are classified as follows

1. According to Size.

Small orifice

Large orifice.

The orifice is small if the head of liquid is more than 5 times the depth of the orifice. The velocity is assumed uniform from the top edge to the bottom edge of the orifice.

The orifice is large if the head of liquid is less than 5 times the depth of the orifice. The velocity is not uniform from the top edge to the bottom edge of the orifice.

2. According to Shape

Circular orifice

Rectangular orifice

Square orifice

Triangular orifice

3. According to the Shape of the Edge.

Sharp-edged orifice

Bell-mouthed orifice (I.e. orifice with round corner).

4. According to the Nature of Discharge.

Free discharging orifice

Drowned or Submerged orifices

Fully submerged orifice

(ii) Partially submerged orifice

SOME IMPORTANT TECHNICAL TERMS

Jet. The continuous stream of a liquid that flows out of an orifice is known as jet .

Vena-contracta. The section of jet where the cross-sectional area is minimum is known as vena-contracta.

Causes for the formation of vena-contracta. Formation of vena-contracta is caused by a change in the direction of motion of liquid particles approaching the orifice.

3.Velocity of Approach. The velocity with which liquid is approaching the orifice **called** velocity of approach.

HYDRAULIC CO-EFFICIENTS (ORIFICE CO-EFFICIENTS)

Four Co-efficients related to discharge through an orifice are commonly known as hydraulic co-efficients of an orifice. They are:

1. Co-efficient of contraction
2. Co-efficient of velocity
3. Co-efficient of discharge
4. Co-efficient of resistance

1. Co-efficient of contraction (C_c) : It is defined as the ratio of area of the jet at vena-contracta to the area of the orifice. It is denoted by C_c .

Mathematically,

$$C_c = \frac{\text{Area of jet at vena-contracta } (a_c)}{\text{Area of orifice } (a)}$$

The value of C_c varies from 0.61 to 0.69 depending upon the shape and size of the orifice and available head of liquid. But the average value of C_c is taken as 0.64.

2. Co-efficient of Velocity (C_v) : It is defined as the ratio of the actual velocity of jet at vena-contracta to the theoretical velocity of jet. It is denoted by C_v .

Mathematically,

$$C_v = \frac{\text{Actual velocity of jet at vena-contracta } (V)}{\text{Theoretical velocity } V_{th}}$$

i.e.
$$C_v = \frac{V}{\sqrt{2gH}}$$

where V = actual velocity

H = head under which the liquid flows out of the orifice

The value of C_v varies from 0.95 to 0.99 depending upon the shape and size of the orifice and the available head of liquid. For sharp-edged orifices the value of C_v is taken as 0.98.

3. Co-efficient of discharge (C_d) : It is defined as the ratio of the actual discharge from the orifice to the theoretical discharge from the orifice. It is denoted by C_d .

Mathematically,

$$C_d = \frac{\text{Actual Discharge (Q)}}{\text{Theoretical discharge } Q_{th}}$$

or
$$C_d = \frac{Q}{a \times \sqrt{2gH}}$$

The value of C_d varies from 0.61 to 0.65 depending upon the shape and size of the orifice and available head of liquid. But the average value of C_d is taken as 0.62.

4. Co-efficient of Resistance (C_r) : It is defined as the ratio of loss of head (or loss of kinetic energy) in the orifice to the head of liquid (actual kinetic energy) available at the exit of the orifice. It is denoted by C_r .

Mathematically,

$$C_r = \frac{\text{Loss of head of the orifice}}{\text{Head of liquid}}$$

The loss of head in the orifice takes place, because the walls of the orifice give some resistance to the liquid as it comes out. Co-efficient of resistance is generally neglected while solving numerical problems.

RELATIONSHIP BETWEEN C_c , C_v and C_d

$$\text{Co-efficient of discharge, } C_d = \frac{\text{Actual Discharge}}{\text{Theoretical Discharge}}$$

$$= \frac{\text{Actual velocity X Actual Area}}{\text{Theoretical velocity X Theoretical area}}$$

$$\text{or } C_d = \frac{\text{Actual Velocity}}{\text{Theoretical Velocity}} \times \frac{\text{Actual Area}}{\text{Theoretical Area}}$$

$$C_d = C_v \times C_c$$

DISCHARGE THROUGH A RECTANGULAR ORIFICE:

The main types of rectangular orifices are:

1. Small rectangular orifices
2. Large rectangular orifices

The orifices are called small and large depending upon the size of the orifice and the head of the liquid from the centre of the orifice.

1. Discharge through a Small rectangular orifice: An orifice is called a small orifice. The head of the liquid (from the centre of orifice) is more than 5 times the depth of the orifice.
In case of small orifice, the velocity in the entire cross-section of the jet is considered to constant.

Let a = Cross section area of the orifice.

H - height of liquid above the centre of orifice.

b - width of the orifice

d - depth of the orifice

C_d - Co-efficient of discharge of the orifice

Discharge, $Q = C_d \times a \times \sqrt{2gH}$

2. Discharge through a Large rectangular orifice: An orifice is called the Large orifice if the head of the liquid is less than 5 times the depth of the orifice.

In case of large orifices, the velocity is not constant over the entire cross-section of the jet and hence Q , cannot be calculated by:

$$Q = C_d \times a \times \sqrt{2gH}$$

Consider a large rectangular orifice in one side of the tank discharging freely into atmosphere under a constant head H as shown in Fig.

Let H_1 - Height of the liquid above top edge of orifice.
 H_2 - Height of the liquid above bottom edge of the orifice.
 b - width of the orifice
 d - depth of the orifice ($H_2 - H_1$)
 C_d - Co-efficient of discharge

Consider an elementary horizontal strip of depth ' dh ' at the depth of ' h ' below the free surface of the liquid in the tank.

$$\text{Area of strip} = b \times dh$$

Theoretical velocity of liquid through strip = $\sqrt{2gh}$

Discharge through elementary strip, $dQ = C_d \times \text{area of strip} \times \text{velocity}$

$$= C_d \times b \times dh \times \sqrt{2gh}$$

Now total discharge through the whole orifice may be found out by integrating the above equation between the limits H_1 and H_2 ,

$$Q = \int_{H_1}^{H_2} C_d \times b \times dh \times \sqrt{2gh} = C_d \times b \times \sqrt{2g} \int_{H_1}^{H_2} \sqrt{h} \, dh$$

$$Q = \frac{2}{3} \times C_d \times b \times \sqrt{2g} \times (H_2^{\frac{3}{2}} - H_1^{\frac{3}{2}})$$

MOUTHPIECES

A mouthpiece is a short length of pipe (two to three times its diameter in length) connected to an orifice. Mouthpieces are used to increase the amount of discharge.

It should be noted that the diameter of the outlet or exit end of the mouthpiece is known as diameter of the mouthpiece.

Classification of Mouthpieces. The mouthpieces may be classified as follows :

1. According to the position of the mouthpiece :

Internal mouthpiece

External mouthpiece

2. According to the shape of the mouthpiece :

Cylindrical mouthpiece

Convergent mouthpiece

Convergent-divergent mouthpiece

3. According to nature of discharge :

Mouthpiece running full

(ii) Mouthpiece running free

Notch

A notch is a kind of opening (throughout the width) to the fluid flow, in which fluid flows through the bottom of notch. It is used to regulate the flow of fluid.

The bottom end of the notch is generally made sharp so that it offers minimum resistance to the fluid flow (generally water).

A notch is generally made up of a metal plate and is used to regulate fluid flow at a small scale.

Types of Notches

Notches can be further classified on the basis of shape of opening and on the basis of effects of the sides on Nappe (or Vein).

1. According to the shape of opening, notches can be classified as

Stepped notch

Trapezoidal notch

Triangular notch

Rectangular notch

2. According to the effects of the sides on Nappe (or Vein), notches can be classified as

Notch without end contraction or suppressed notch

Notch with end contraction

Weir

A weir is a concrete or masonry structure which is located at the bottom side (throughout width) in the path of fluid flow. The fluid (generally water) flow above the weir.

A weir is generally used to regulate flow of water at a large scale, like in rivers or canals.

A weir has considerable width along the length of fluid flow.

Types of Weirs

Weirs can be classified on the basis of shape of opening, on the basis shape of Crest (or Sill) and on the basis of effects of sides on the Nappe (or Vein).

On the basis of shape of opening, weirs can be classified as

Trapezoidal weir (Cipolletti Weir)

Triangular weir

Rectangular weir

2. According to the shape of the Crest, weirs can be classified as

Ogee shaped weir

Broad crested weir

Narrow crested weir

Sharp crested weir

3. According the effect of sides on nappe (or vein), weirs can be classified as

Weirs without end contraction

Weirs with end contraction

Differences between notches and weirs

Below are the differences between notches and weirs in tabular form.

	Notch	Weir
1	Used to regulate discharge of small channels	Used to regulate discharge of large channels, like canals and rivers
2	They are smaller in size	They are bigger in size
3	They are usually made of metallic plate	They are usually made of concrete
4	Fluid flows below the notch	Fluid flows above the Weir

CURRENT METER

The velocity of flow at any point in the open channel can be most accurately and conveniently determined by means of a mechanical device named current-meter. Current-meter of common use may be classified in two categories according to the type of revolving part used.

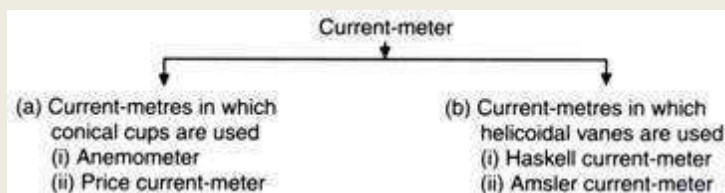

Figures give clear idea about two types of current-meters. In Fig. Price current-meter is shown in which a wheel of conical cups (6 to 8) is mounted on arms of a vertical axis. In Fig. Amsler current-meter is shown in which a series of helicoidal vanes is mounted on a horizontal axis.

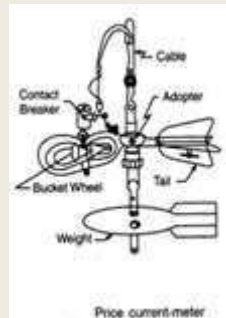

The first type of current-meter is better in the following respects:

- i. Frictional resistance is usually less.
- ii. It starts working even in a current of small velocity.
- iii. It does not revolve too rapidly under high velocity flow.
- iv. It tends to measure full velocity of flow even if it is not oriented very accurately.
- v. In turbulent flow it over-registers the velocity. On the other hand propeller type current meter under registers velocities by about same amount.

Only disadvantages of conical type current-meter are that while lowering the cup wheel starts rotating even if the water is still.

The current-meter with conical cups is more popular because of its accuracy and efficient working.

In principle the working of the two types is based on the same theory and can be outlined as mentioned below:

1. Working of Current-Meters:

When the meter is lowered in water and when it faces the current of water in the channel the wheel rotates. To keep the meter facing the direction of flow a tail is attached. This tail aligns the meter in the direction of flow. The meter is also fitted with a streamlined weight (fish weight) which keeps the meter in a vertical position. The rate of rotation of the wheel depends on the velocity of flow. A dry battery is kept on the shore or in a boat and an electric current is passed to the wheel from it. A commutator is fixed to the shaft of the revolving wheel.

It makes and breaks the contact in an electrical circuit at each revolution. An automatic revolution counter is kept in the boat or on the shore with the battery which registers the

revolutions. When an electric circuit is broken an electric bell in the boat rings or a head phone in the boat buzzes. Then the time taken for a required number of revolutions may be noted. The velocity of flow can be read from a rating table. The rating table is always provided with the meter.

2. Rating of Current-Meter:

The speed of rotation of the cup wheel is a function of the velocity of flow. The cup wheel rotates due to relative velocity between water and the cup wheel. This fact is utilized in calibration of the current-meter. Current-meter is rated in a long tank (say 150 m long) with sectional area 4 m x 2.5 m. On both sides of the tank rails are provided. A trolley runs over the rails with known velocities. Generally equipment is provided on the trolley to automatically record the current-meter revolutions, time and distance travelled.

A current-meter is lowered in the still water of the tank from the trolley by a suspension rod. The trolley is run over the tank at different known velocities for number of times. The number of rotations of the current-meter cup wheel for various velocities are noted.

From the readings a rating curve is prepared. It comes out to be a straight line and the equation is of the form $V = M R + C$ where V is velocity, R is revolutions of cup wheel per second and M and C are constants. Every current-meter whether new or old should be rated before putting it into use. In addition it is essential to calibrate every current-meter periodically.

3. Methods of Supporting Current-Meters:

So far as possible the current-meter should be suspended in the similar way as it done for ratings. When the depth of water in the channel is more, the current-meter is suspended by means of a fine cable or a wire rope and lowered to the required depth. Here it becomes necessary to use a boat for suspending the current-meter. The boat should be fig. 15.8. Current-meter measurement in equipped with the arrangement required for raising rivers and lowering the meter .

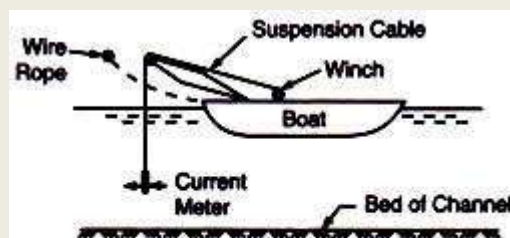

Fig. 15.8. Current-meter measurement in rivers

The boat is moored to the wire rope which is stretched across the river, at the determined point in the river. When the channel carries water at shallow depths the suspension cable and the weight is removed and the current-meter is mounted on a wading rod. The rod is made to rest on the channel bed at required position for taking measurements. In this method as the water is shallow

boat is not required. The current-meter may be fixed at any depth on the wading rod for observing velocity.

4. Methods of Measuring Velocity:

When the velocity is measured by the current-meter at 0.5 D then to get mean velocity of the section the observed velocity should be multiplied with a coefficient 0.96. Alternatively, to obtain mean velocity of flow at a particular section, velocities may be observed at 0.2 and 0.8 of depth from water surface.

The mean of these two readings gives mean velocity of flow at that section. Generally mean velocity of flow at a section is obtained by keeping the meter at 0.6 B. In the observed velocity corrections are made for any obliquity of the current with the cross-section line and also for drift. It is necessary to conduct vertical velocity distribution experiment at each site to decide point of average velocity.

Chapter-7

Flow Through Pipes

Definition:

DEFINITION OF PIPE FLOW, REYNOLDS NUMBER, LAMINAR AND TURBULENT FLOW EXPLAINED THROUGH REYNOLD'S EXPERIMENT

Definition of pipe flow

A pipe is defined as a closed conduit of any cross-section which is used to carry water or any other liquid under pressure and it has no free surface.

The various cross-sections of pipes are shown in (a), (b) and (c).

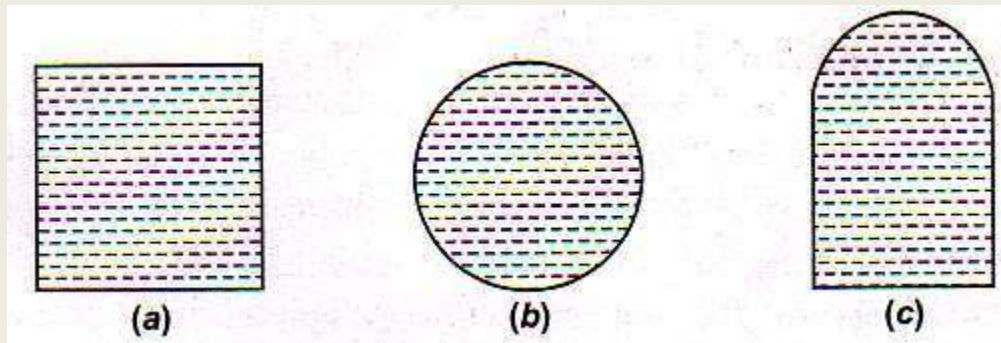

Fig (a) is of rectangular cross-section, (b) is of circular cross-section Fig and (c) is a combination of rectangular cross-section Fig and circular cross-section *i.e.*, bottom is rectangular and top is of a curved shape. In a pipe flow, the flow is under pressure *i.e.*, flow in a pipe takes place due to difference of pressure between different sections of the pipe. The circular section of the pipe which generally runs full is used for water supply distribution in a city or town. When the pipe is partially full, the pressure inside the pipe is equal to atmospheric pressure and the flow is not under pressure as in the case of carrying water upto water treatment plant or sewer line.

Laminar and turbulent flow

Laminar flow is also called streamline flow or viscous flow. It indicates the fluid flow in the form of laminar or layers sliding over each other. Each particle of the fluid moves strictly in a straight line as shown in (a). The laminar flow occurs in the following conditions when ;

- (a) the size of the pipe is small.
- (b) viscosity of fluid is high.
- (c) velocity of flow is low.

The motion of two particles A and B as shown in figure is strictly along a straight line and the paths followed by them do not interfere with each other. A highly viscous oil flowing in a small size closed conduit at a small velocity is a familiar example of laminar flow.

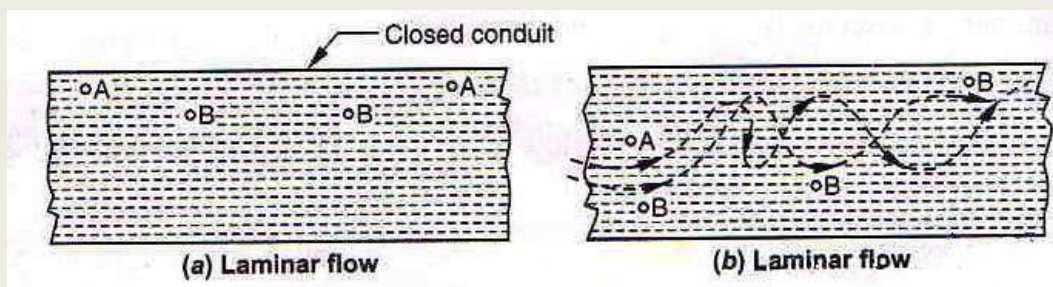

In turbulent flow as shown in Fig (b), the fluid particles A and B flow in an irregular and erratic path *i.e.*, instead of straight line they follow irregular curves which may be steady or unsteady flow with very little viscous resistance of the fluid. The fluid near the boundary is almost stationary and the velocity of the fluid particles goes on increasing as their distance from the boundary wall increases. This increases the viscous resistance between the adjoining layers of fluid. To overcome this resistance, there is a loss of energy as the fluid moves in the forward direction.

Reynold's number

The flow of a fluid in motion is governed by various forces named as inertia forces, viscous forces, gravity forces, surface tension forces, compressibility forces and pressure forces etc. In 1883, an English Engineer Osborne Reynold made a scientific approach to differentiate between laminar and turbulent flow. He considered inertia forces and viscous forces, and formulated that the flow of fluids is controlled by velocity, viscosity of fluid particles and size of the pipe. Thus, he found out a number R_N known as Reynold's number to distinguish between laminar and turbulent flow.

Reynold's number is given by the expression

$$R_N = \frac{vd}{\nu}$$

where ν = mean velocity of flow in m/s

d = Diameter of pipe in meters

ν = Kinematic viscosity of fluid

Kinematic viscosity of fluid ν is given by the expression

$$\nu = \frac{\mu}{\rho}$$

where, μ = Absolute or dynamic viscosity of fluid or co-efficient of viscosity

ρ = Mass density of fluid

By substituting the value of kinematic viscosity i.e., $\nu = \frac{\mu}{\rho}$ in equation (i)

$$R_N = \frac{vd\rho}{\mu}$$

Depending upon the value of R_N , the type of flow is as follows ;

- (a) For laminar or viscous flow, R_N is less than 2000.
- (b) For turbulent flow, R_N is more than 4000.
- (c) For R_N between 2000 and 4000 the flow is laminar or turbulent. This zone is called critical velocity zone

When the value of $R_N = 2000$, the velocity of fluid is called lower critical velocity and when $R_N = 4000$ the velocity is known as higher critical velocity.

Laminar and turbulent flow explained through Reynold's experiment

Reynold by the use of simple experiment demonstrated the difference between the laminar flow and turbulent flow. The apparatus consists of the following accessories;

- (i) A constant heat tank filled with water.
- (ii) A transparent horizontal glass tube a b o u t 1.5 m long and 5cm in diameter provided with a bell mouthed entrance at one end and a control valve at the downstream end.
- (iii) A small tank containing dye i.e., potassium permanganate solution.
- (iv) A differential pressure manometer to determine characteristics of laminar and turbulent flow i.e., critical velocities. The whole set up is as shown in Fig

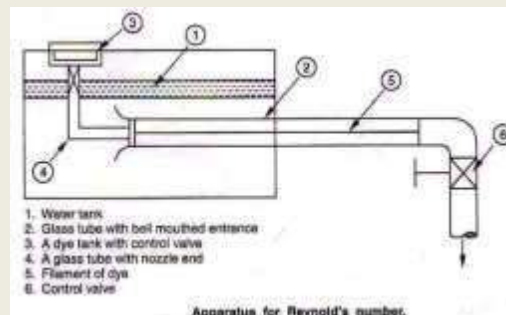

Procedure : The water from the tank was allowed to flow through the glass tube. The velocity of flow was varied by adjusting the control valve. A liquid dye with specific weight

equal to that of water was introduced into the water flowing through bell mouthed glass tube. The following observations were made by Reynold as shown in (a), (b) and (c).

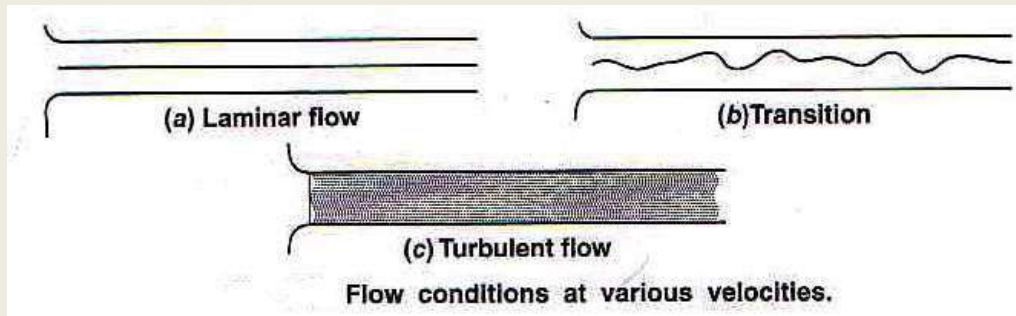

- (i) When the velocity of flow was low, the dye filament in the glass tube was in the form of a straight line. This straight line of dye filament was parallel to the glass tube which was the case of a laminar flow as shown in (a).
- (ii) With the increase in velocity of flow, the dye filament becomes wavy as shown in (b) and this is called the transitional state.
- (iii) With the further increase in velocity of flow, the wavy dye filament broke up and diffused in water as shown in Fig. (c) and is called turbulent flow.

Therefore, on the basis of experiment Reynold discovered that ;

- (i) in case of laminar flow, loss of pressure head $\propto v$.
- (ii) in case of turbulent flow, loss of pressure head $\propto v^2$.

More accurately the pressure head $\propto v^n$, where n varies from 1.75 to 2.

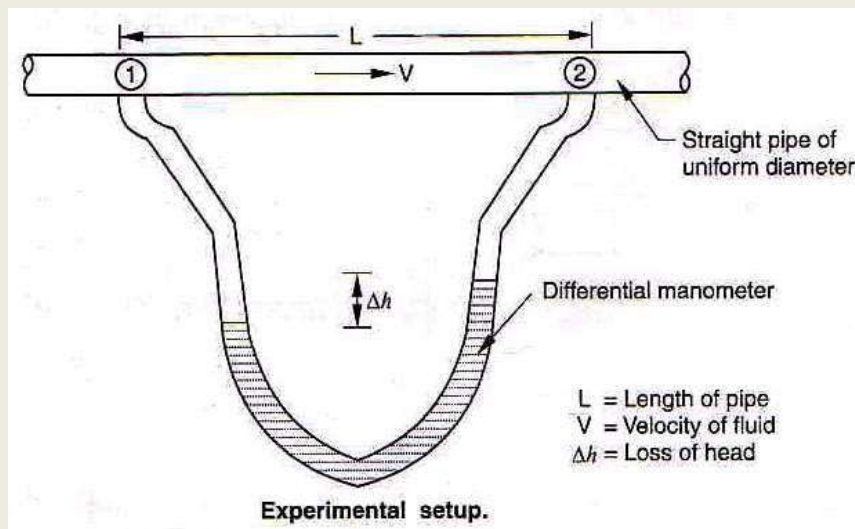

The critical velocities at which the laminar flow changed into turbulent flow were determined by using a differential manometer connected to a straight circular pipe. The experimental set up was as shown in Fig. In the experiment, the energy loss for a pipe length 'L' and velocity 'V' was determined in terms of loss of head h_f by connecting differential manometer between

sections (1) and (2). The mean velocity of flow was calculated from the known volume of flowing through pipe.

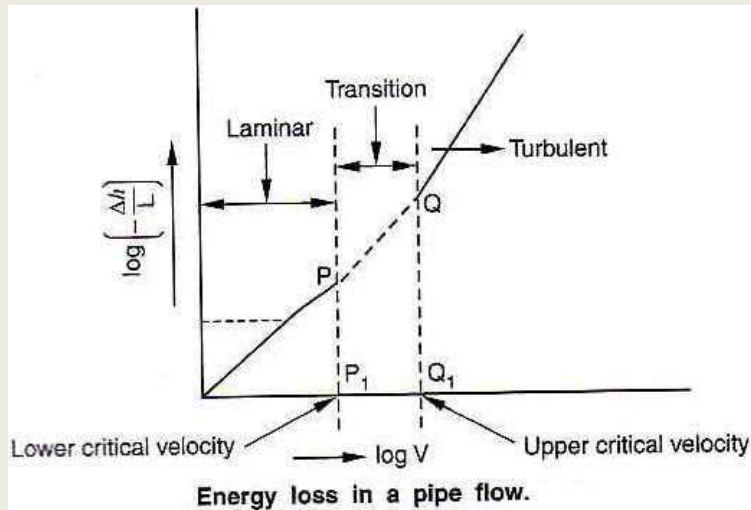

The loss of head h_f at various velocities was determined and the logarithmic graph was plotted as shown in Fig. In the region of laminar flow energy loss of head $h_L \propto V$, while in turbulent region $h_L \propto V^2$. Between the laminar region and turbulent region, there was a transition region. Points P and Q on the curve showed the lower critical velocity and upper critical velocity of the flow.

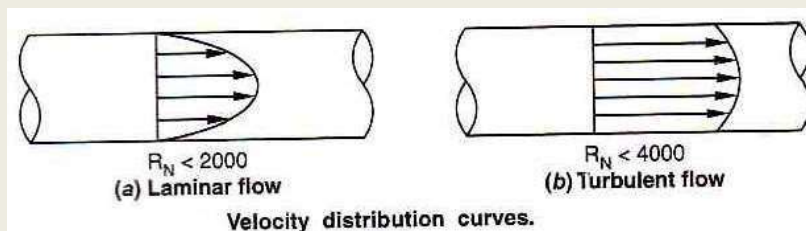

Fig shows the velocity distribution curve. In Fig. (a) which shows laminar flow where velocity was zero at the pipe surface and maximum at the centre because $R_N < 2000$ and at the surface of the pipe the liquid did not slip. But in turbulent flow as shown in Fig. (b) the velocity was not zero at the pipe surface but was maximum at the centre because $R_N > 4000$.

CRITICAL VELOCITY AND VELOCITY DISTRIBUTIONS IN A PIPE FOR LAMINAR CRITICAL VELOCITY

The minimum velocity at which the flow changes from the laminar flow to the turbulent flow is called critical velocity.

The flow conditions are laminar if the velocity of flow is less than the critical velocity. If the velocity of flow becomes more than the critical velocity, then flow is called turbulent.

Velocity distribution of a laminar flow : In a laminar flow the velocity profile is parabolic i.e., it is zero at the pipe surface and is maximum at the centre. The laminar flow occurs when Reynold's number is less than 2000.

HEAD LOSS IN PIPELINES DUE TO FRICTION, SUDDEN EXPANSION AND SUDDEN CONTRACTION, ENTRANCE, EXIT, OBSTRUCTION AND CHANGE OF DIRECTION (NO DERIVATION OF FORMULA)

Loss of head in pipe due to friction

Consider a uniform horizontal pipe, having steady flow as shown in Fig

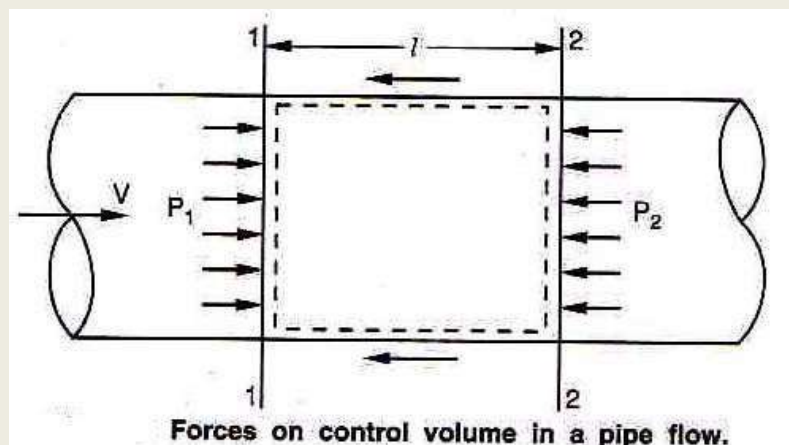

Let, l = Length of pipe considered between sections 1 - 1 and 2 - 2.

d = Diameter of pipe

V = Mean velocity of water

P_1 = Pressure intensity at section 1 - 1

P_2 = Pressure intensity at section 2 - 2

f' = frictional resistance per unit area per unit velocity

P = Wetted perimeter of pipe

h_f = Loss of head due to friction.

Applying Bernoulli's equation between section 1-1 and section 2-2 ;

Total head at 1-1 = Total head at 2-2 + Loss of head due to friction between 1-1 and 2-2

$$\frac{P_1}{w} + \frac{v_1^2}{2g} + Z_1 = \frac{P_2}{w} + \frac{v_2^2}{2g} + Z_2 + h_f$$

Since, pipe is horizontal

$Z_1 = Z_2$ as diameter of pipe is same at sections 1-1 and 2-2

So,

$$\frac{P_1}{w} = \frac{P_2}{w} + h_f$$

or

$$h_f = \frac{P_1}{w} - \frac{P_2}{w}$$

Intensity of pressure will be reduced due to frictional resistance in the direction of flow.

Frictional resistance = Frictional resistance per unit wetted area per unit velocity

\times Wetted area \times (Velocity)².

$$F_1 = f' \times \pi dl \times V^2$$

$$F_1 = f' \times P \times L \times V^2 \quad [\because \pi d = \text{Perimeter} = P]$$

The forces acting on the fluid between sections 1-1 and 2-2 are ;

(i) Pressure force at section 1-1 = $P_1 \times A$

(ii) Pressure force at section 2-2 = $P_2 \times A$

(iii) Frictional resistance, F_1 .

Resolving all forces in the horizontal direction, we have

$$P_1 A - P_2 A - F_1 = 0 \Rightarrow (P_1 - P_2) A = F_1$$

$$(P_1 - P_2) A = f' \times P \times l \times V^2 \Rightarrow P_1 - P_2 = \frac{f' P l V^2}{A}$$

But from equation (i), $h = \frac{P_1}{\rho g} - \frac{P_2}{\rho g}$ or $P_1 - P_2 = \rho g h_f$

So, $\rho g h_f = \frac{f' P l V^2}{A}$ or $h_f = \frac{f'}{\rho g} \frac{P}{A} l V^2$

As, $\frac{P}{A} = \frac{\text{Wetted Perimeter}}{\text{Area}} = \frac{\pi d}{\frac{\pi d^2}{4}} = \frac{4}{d}$

$$h_f = \frac{f'}{\rho g} \cdot \frac{4}{d} \cdot l \cdot V^2 = \frac{f'}{\rho g} \cdot \frac{4 l V^2}{d}$$

Putting the value of $\frac{f'}{\rho g} = \frac{f}{2g}$ (Where f is a co-efficient of friction)

We got $h_f = \frac{f}{2g} \cdot \frac{4 l V^2}{d}$

i.e. $h_f = \frac{4 f l V^2}{2 g d}$

This equation is commonly used for finding the loss of head due to friction in pipes.

Loss of energy (or Head) in pipes

When water flows in a pipe, it experiences some resistance to its motion due to which its velocity and ultimately the head of water available is reduced. This loss of energy (or head) is classified as follows :

ENERGY LOSSES

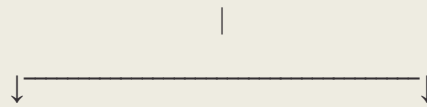

Major Energy Losses

This loss is due to friction and is

calculated by the following formulae

1. Darcy-Weisbach Formulae
2. Chezy's formulae

Minor energy losses

These losses are due to

1. Sudden expansion of pipe
2. Sudden contraction of pipe
3. Bend in pipe
4. Pipe fittings
5. An obstruction in pipe.

Minor Energy (Head) Losses

The loss of head or energy due to friction in a pipe is known as major loss while the loss of energy due to change of velocity of the flowing fluid in magnitude or direction is called minor loss of energy. The minor loss of energy (or head) includes the following cases.

1 Loss of head due to sudden enlargement : Consider a liquid flowing through a pipe which has sudden enlargement as shown in fig. Consider two sections 1 - 1 and 2 - 2 before and after the enlargement. Due to sudden change of diameter of the pipe, the liquid flowing from the smaller pipe is not able to follow the abrupt change of boundary.

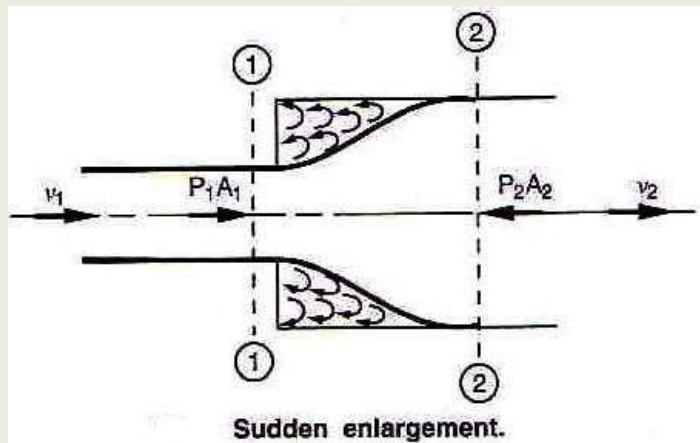

Thus, the flow separates from the boundary and turbulent eddies are formed as shown in Fig. The loss of head takes place due to the formation of these eddies. The loss of head due to sudden enlargement will be ;

$$h_e = \frac{(V_1 - V_2)^2}{2g}$$

where, V_1 = Velocity of flow at section 1 - 1

V_2 = Velocity of flow at section 2 - 2

2 Loss of head due to sudden contraction : This occurs where the cross-sectional area of the pipe becomes suddenly smaller. Consider a liquid flowing through a pipe which has a sudden

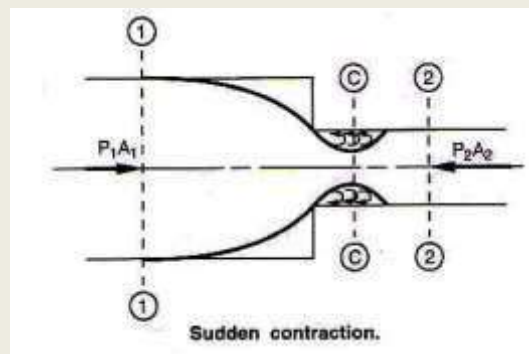

contraction in area as shown in Fig.

Consider two sections 1 - 1 and 2 - 2 before and after the contraction. As the liquid flows from larger pipe to the smaller pipe, the area of flow goes on decreasing and becomes minimum at a section C - C as shown in Fig. This section C - C is called vena contracta. After section C - C, a sudden enlargement of the area takes place. The loss of head due to sudden contraction is actually due to sudden enlargement from vena contracta to smaller pipe.

$$h_c = \frac{kV_2^2}{2g}$$

where,

V_2 = Velocity of flow at section 2 - 2

and

$$k = \left[\frac{1}{C_c} - 1 \right]^2$$

If the value of C_c is assumed to be equal to 0.62,

then

$$k = \left[\frac{1}{0.62} - 1 \right]^2 = 0.375 \text{ i.e. } h_c = 0.375 \frac{kV_2^2}{2g}$$

if the value of C_c is not given, then the head loss due to contraction is taken as;

$$h_i = 0.5 \frac{V_2^2}{2g}$$

3. Loss of head at the entrance of a pipe : This is the loss of energy which occurs when a liquid enters the pipe from a tank or large container. This loss is similar to the loss of head due to sudden contraction. It is denoted by h_i

$$h_i = 0.5 \frac{V^2}{2g}$$

where,

V = Velocity of liquid pipe

4. Loss of head at the exit of pipe : This loss occurs due to the rejection of kinetic energy *i.e.* due to the velocity of liquid at outlet of the pipe which is dissipated either in the form of free jet or it is lost in the tank or reservoir. It is denoted by h_o

$$h_o = \frac{V^2}{2g}$$

where,

V = Velocity of liquid at the outlet of pipe.

5. Loss of head due to obstruction in pipe : Refer Fig. The loss of energy occurs whenever there is an obstruction to the flow. An obstruction will cause a contraction of the area of flow which will be followed by an enlargement when the obstruction is passed

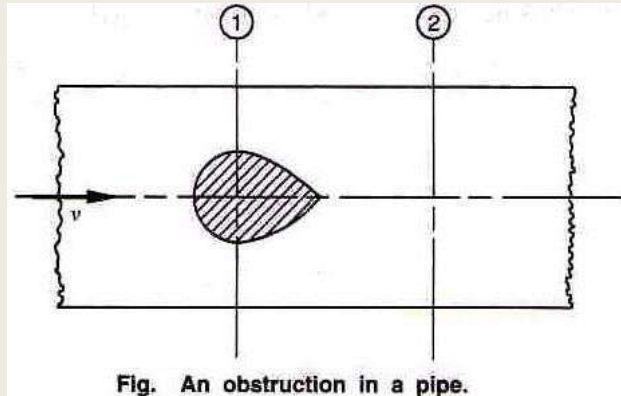

Fig. An obstruction in a pipe.

Head loss due to obstruction (h_{obs}) is given by the relation,

$$h_{obs} = \left[\frac{A}{C_c(A-a)} \right]^2 \frac{V^2}{2g}$$

where,

A = Area of the pipe

a = Maximum area of obstruction

v = Velocity of liquid in pipe

6. Loss of head due to bend in pipe : When there is any bend in a pipe, the velocity of flow changes, due to which the separation of the flow from the boundary and formation of eddies takes place. Thus, the energy is lost. Loss of head in pipe due to bend is given as ;

$$h_b = \frac{KV^2}{2g}$$

Where,

V = Velocity of flow and K = Co - e f f i c i e n t of bend

The value of K; depends upon ;

- (i) Angle of bend
- (ii) Radius of curvature of bend
- (iii) Diameter of pipe.

7. Loss of head in various pipe fittings : The loss of head in various pipe fittings such as valves, couplings etc. may also be represented as;

$$h_{pf} = k \frac{v^2}{2g}$$

where, V = Mean velocity of flow in the pipe

k = Value of co-efficient.

Value of k depends on the type of the pipe fitting.

HYDRAULIC GADIENT AND TOTALENERGY LINE

The concept of hydraulic gradient line and total energy line is quite useful study of flow of fluid in pipes, These lines may be obtained as indicated below;

HYDRAULIC GADIENt Line (H.G.L.)

The sum of datum head or potential, (Z) and the pressure head ($\frac{P}{w}$) any point is called the pitzometric head. If a line is drawn, joining the piezometric levels at various points, the line so obtained is called the '*Hydtaulic gradient line*'.

Total Energy Line or Energy Gradient Line (T.E.L. or E.G.L.)

We know that, the total head (*which is also total energy per unit weight with respect to any arbitrary datum*) is the sum of the potential head, pressure head and velocity head.

i.e.
$$\text{Total Head} = \frac{P}{w} + Z + \frac{v^2}{2g}$$

When the fluid flows a l o n g the pipe, there is loss of head (*energy*) and the t6tal energy decreases in the direction of flow. If the total energy at various points along the axis of the pipe is plotted and joined by a line, the line so obtained is called the Energy Gradient Line (E.G.L.) It is also known as Total Ener gy Line (T.E.L.).

Remember :

1. E.G.L. always drops in the direction of flow because of *loss* of head.
2. H.G.L. may rise or fall depending upon the pressure changes.
3. H.G.L. is always below the E.G.L. by $\frac{v^2}{2g}$

Cases :

Case 1. **Uniform flow** : Consider the flow of water through a uniform diameter as shown in Fig.

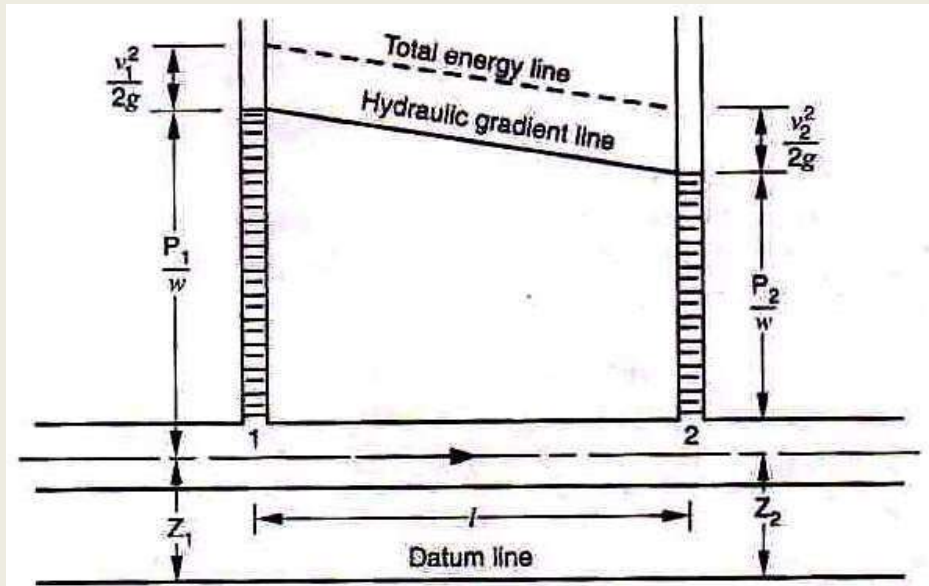

For point 1, $H_1 = \frac{p_1}{w} + \frac{v_1^2}{2g} + Z_1$

For point 2, $H_2 = \frac{p_2}{w} + \frac{v_2^2}{2g} + Z_2$

Loss of head $h_f = \frac{p_1}{w} + \frac{v_1^2}{2g} + Z_1 - \left(\frac{p_2}{w} + \frac{v_2^2}{2g} + Z_2 \right)$

$v_1 = v_2$ [as pipe is uniform]

and $Z_1 = Z_2$ [as pipe is horizontal]

$\therefore h_f = \frac{p_1}{w} - \frac{p_2}{w}$

The line joining the liquid levels in these two tubes will be the hydraulic gradient line as shown in Fig.

The total energy line will lie at a distance of $v^2/2g$ above the hydraulic gradient line.

Case 2. Non-uniform flow : Now, let us consider a typical case of non-uniform flow where the pipeline is having different diameter for different lengths as shown in Fig. Following points emerge from the case of non-uniform flow ;

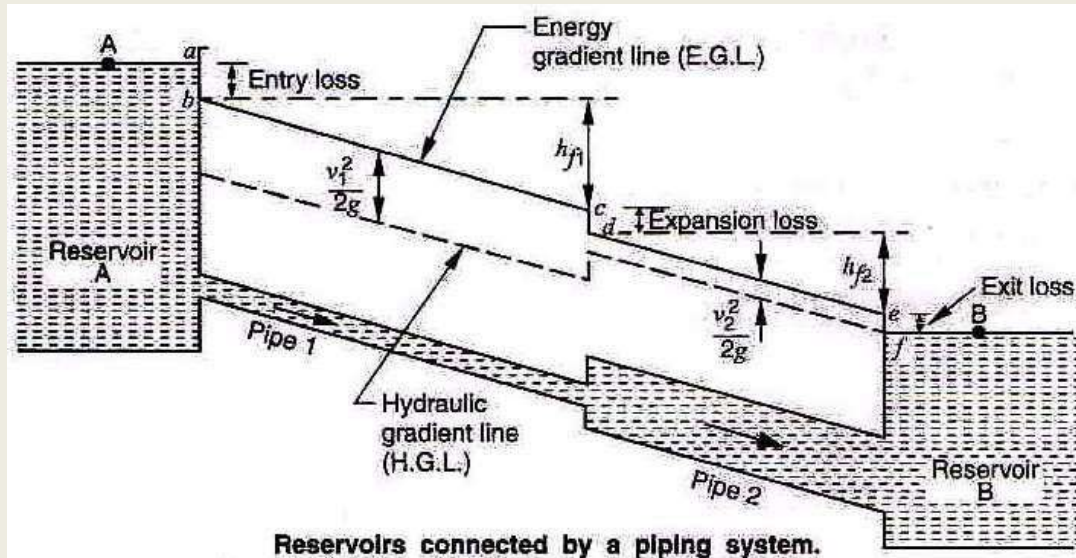

1. Since, velocity is essentially zero in a reservoir, H.G.L. and E.G.L. are coincident with the liquid surface.
2. At the entrance to the pipe from the reservoir, entrance losses are experienced and E.G.L. drops. There is also a fall in H.G.L. due to the liquid flowing with a certain velocity *i.e.* there is uniform loss due to friction.
3. As liquid enters from pipe 1, to pipe 2 there is loss due to sudden expansion *i.e.* the flow velocity would decrease with pipe expansion. Consequently, the pressure will grow and H.G.L. will be set up, while E.G.L. drops as shown by line *ed* in Fig.

Now in pipe 2, there is a uniform loss due to friction. H.G.L. and E.G.L. lines drop as shown in Fig. When liquid enters from pipe 2 to reservoir B, exit loss occurs.

FLOW FROM ONE RESERVOIR TO ANOTHER THROUGH A LONG PIPE OF UNIFORM CROSS-SECTION (SIMPLE PROBLEMS)

Two reservoirs A and B as shown in Fig. 7.14 are connected through a long pipe of uniform

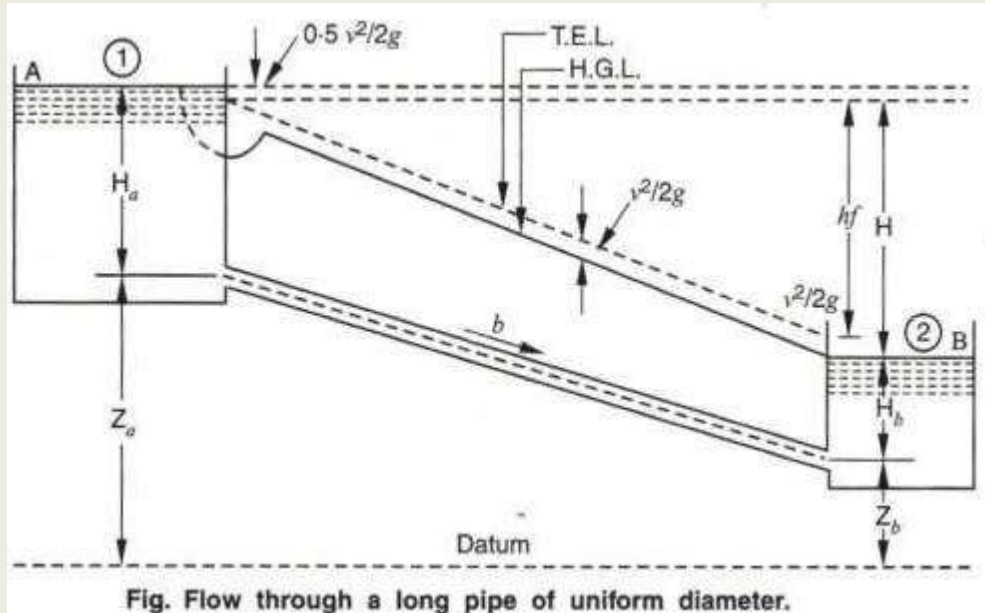

cross-section having diameter ' d '.

Let ' v ' be the velocity of flow in m/s .

The various losses occurring in the pipe are as ;

$$\text{Loss of head at the entrance of a pipe, } h_i = \frac{0.5v^2}{2g}$$

$$\text{Loss of head at the exit of pipe, } h_o = \frac{v^2}{2g}$$

$$\text{Loss of head due to friction in pipe, } h_f = \frac{4flv^2}{2gd}$$

H_a = Head of the liquid of reservoir A above the centre line of pipe.

H_b = Head of the liquid of reservoir B above the centre line of pipe.

Z_a = Datum height of centre line of pipe at reservoir A.

Z_b = Datum height of centre line of pipe at reservoir B.

As per Bernoulli's equation between points (1) and (2) in the reservoirs A and B respectively

$$H_a + Z_a = H_b + Z_b + \frac{0.5v^2}{g} + \frac{4flv^2}{2gd} + \frac{v^2}{2g}$$

or $(H_a + Z_a) - (H_b + Z_b) = 1.5 \frac{v^2}{2g} + \frac{4flv^2}{2gd}$

$\therefore = \frac{v^2}{2g} \left(1.5 + \frac{4fl}{d} \right)$

Or $(H_a + Z_a) - (H_b + Z_b) = H$

= Difference in the liquid surface between reservoirs A and B

$\therefore = \frac{v^2}{2g} \left(1.5 + \frac{4fl}{d} \right)$

From equation (i), the difference in liquid surfaces is equal to the sum of various losses.

\therefore The velocity of flow 'v' can be calculated from equation (i).

When the pipeline is lengthy, the loss of head due to friction will be more in comparison to other losses *i.e.*, loss at entrance and loss at exit. Therefore, considering only frictional loss in equation (i).

$$H = \frac{4flv^2}{2gd}$$

or Velocity of flow, $v = \frac{\sqrt{2gHd}}{fl}$

If the pipe discharges into atmosphere ;

Then, $H_b = 0$

and $H = H_a + Z_a - Z_b$, the velocity is determined by using equation (i).

PIPES IN SERIES AND PARALLEL

Flow in series or compound pipe

The pipes are said to be in series or compound when different diameters and different lengths are connected to one another. Here the rate of discharge Q is the same in all the pipes and total loss of head is sum of loss in head of all the pipes.

Two reservoirs A and B as shown in Fig are connected through a compound pipe or pipes in

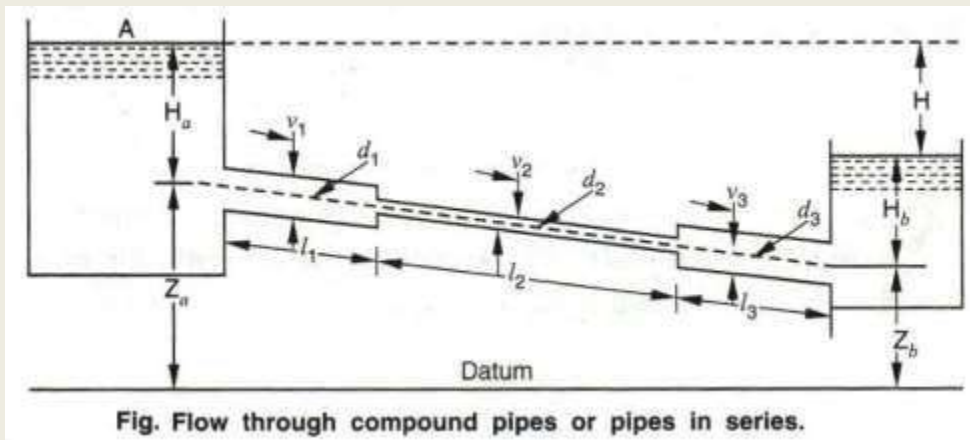

series. In the figure, three pipes of diameters d_1 , d_2 and d_3 and lengths l_1 , l_2 and l_3 respectively are involved in flow through the pipes in series.

Let V_1 , V_2 and V_3 be the velocities of flow in three pipes respectively and the difference of head between reservoirs A and B is H .

$$\therefore H = (H_a + Z_a) - (H_b + Z_b)$$

Under this head the flow takes place between reservoirs A and B.

$$H = \frac{0.5v_1^2}{2g} + \frac{4f_1l_1v_1^2}{2gd_1} + \frac{0.5v_2^2}{2g} + \frac{4f_2l_2v_2^2}{2gd_2} + \frac{(v_2 - v_3)^2}{2g} + \frac{4f_3l_3v_3^2}{2gd_3} + \frac{v_3^2}{2g} \quad \dots(i)$$

Equating H to different losses in pipeline ;

$$H = \frac{4f_1 l_1 v_1^2}{2gd_1} + \frac{4f_2 l_2 v_2^2}{2gd_2} + \frac{4f_3 l_3 v_3^2}{2gd_3} \quad \dots(ii)$$

Neglecting minor losses in the above expression, the equation can be written as

By the continuity equation,

$$Q = \frac{\pi}{4} d_1^2 v_1 = \frac{\pi}{4} d_2^2 v_2 = \frac{\pi}{4} d_3^2 v_3 \quad \dots(iii)$$

By the continuity equation,

These equations can be used to solve problems of pipelines in series.

Flow through pipes in parallel

The pipes are said to be in parallel when a main pipe divides into two or more parallel pipes which again join together downstream and continue as main pipe. Here the discharge Q in the main pipe is equal to the discharges in each of the parallel pipes and the loss of head in each pipe is the same. Two water tanks A and B whose water level is same for both the pipes laid in parallel are shown in Fig. Now, as per the condition given above it is obvious that the loss of head or frictional loss of each pipe remains same and the pipes discharge independently.

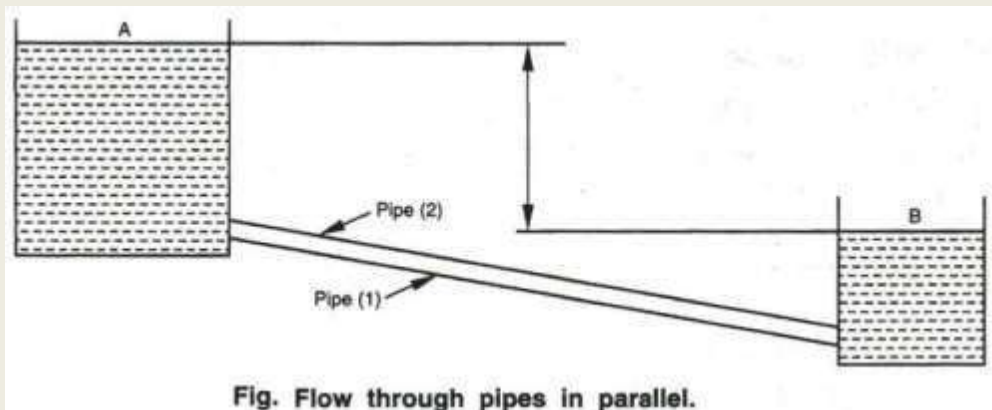

Let h_f be the loss of head due to friction for both the pipes which remains constant and the total discharge Q is simple addition of Q_1 Q_2 determined independently for each pipe.

l_1 = Length of pipe (1)

d_1 = Diameter of pipe (1)

$v_1 =$ Velocity of water in pipe (1)

Similarly,

$l_2 =$ Length of pipe (2)

$d_2 =$ Diameter of pipe (2)

$v_2 =$ Velocity of water in pipe (2)

For parallel pipes, loss of head h_f due to friction is same in both the pipes between the two tanks.

$$\therefore h_f = h_{f_1} = h_{f_2}$$

Where, $h_{f_1} =$ Loss of head in pipe (1)

And $h_{f_2} =$ Loss of head in pipe (2)

But
$$h_{f_1} = \frac{4fl_1v_1^2}{2gd_1}$$

And
$$h_{f_2} = \frac{4fl_2v_2^2}{2gd_2}$$

$$\therefore v_1 = \sqrt{\frac{2gd_1h_f}{4fl_1}}$$

And
$$v_2 = \sqrt{\frac{2gd_2h_f}{4fl_2}}$$

Also $Q = A \times V$

$$\therefore Q_1 = A_1 \times V_1 \text{ and } Q_2 = A_2 \times V_2$$

Since, A_1 and A_2 are given, V_1 and V_2 can be determined.

Total discharge, $Q = Q_1 + Q_2$

If there are more pipes, then $Q = Q_1 + Q_2 + Q_3$ etc.

WATER HAMMER PHENOMENON AND ITS EFFECTS (ONLY DEFINITION AND DESCRIPTION)

Water Hammer in pipes

If water is flowing through a long pipeline and the flow of water is suddenly brought to rest position by closing the valve, the momentum of flowing water is destroyed. This changes the kinetic energy into the strain energy which will result in the sudden rise of pressure at the point of the closed valve. The rise of pressure will travel backward in the form of a pressure wave along the pipe length causing noise. The noise that occurs due to the travel of the pressure wave backwards into the pipeline is known as **knocking**. The sudden rise in pressure of water in the pipeline due to sudden stoppage of valve is known as water hammer or hammer blow .

The magnitude of pressure rise depends upon the following :

- (i) The speed at which the valve is closed.
- (ii) The velocity of flow.

The length of pipe.

The elastic properties of the pipe material as well as that of the flowing fluid.

The rise in pressure in some cases may be so large that the pipe may even burst and therefore, it is essential to take into account this pressure rise in the design of the pipes. The following cases of water hammer in pipes will be considered :

1. Gradual closure of valve.
2. Instantaneous closure of valve in rigid pipes.
3. Instantaneous closure of valve in elastic pipes.

1. Gradual closure of valve : Considering liquid to be incompressible and pipe walls to be rigid and inelastic, gradual closure of valve will cause uniform retardation and less increase in pressure.

(a) The valve closure is said to be gradual, if $t > \frac{2l}{c}$.

(b) The valve closure is said to be sudden , if $t < \frac{2l}{c}$.

where, t = Time taken to close the valve in seconds.

c = Velocity of pressure wave in m/s .

l = Length of pipe in m .

2. Instantaneous closure of valve in rigid pipes : In this case, the valve is suddenly closed and the increase in pressure intensity will become very large. Under *this*, it is assumed that pipe walls are rigid and inelastic and hence, they do not get distended when the intensity of pressure increases periodically due to sudden closure. It is, however, assumed that volume of liquid decreases due to the compressibility of the liquid. The value of increase in intensity of pressure can be found by considering the fact that loss of kinetic energy of liquid will be equal to strain energy in the liquid.

3. Instantaneous closure of valve in elastic pipes : In *this* case, the valve is suddenly closed and increase in pressure intensity will become very large. When intensity of pressure increases, the pipe walls get distended and the compressibility of liquid will take place. In *this* case, loss of kinetic energy of liquid will be equal to strain energy stored in liquid column and in pipe walls.

Exercises

1. Fill in the blanks:-

- i. The pipe running partially full behaves like an
- ii. In a laminar flow, Reynolds number is
- iii. In a turbulent flow, Reynolds number is
- iv. Darcy-Weisbach equation is used to find loss to head due to
- v. Chezy's formula is given as

2. Theoretical Question

- i. Define flow through pipes.
- ii. Define Laminar and Turbulent flow.
- iii. What is Reynolds number?
- iv. What is the significance of Reynolds number?
- v. What do you mean by critical velocity?
- vi. Define a pipe.
- vii. What do you mean Total energy line?
- viii. Define hydraulic gradient line.
- ix. What is equivalent pipe?
- x. What is a nozzle? State its uses.

3. Numerical Problems

- i. Find the head lost due to friction in a pipe of diameter 300 mm and length 5000 mm,

through which water is flowing at a velocity of 3 m/s using

(a) Darcy formula (assuming $f = 0.00256$)

(b) Chezy's formula for which $C = 60$.

- ii. Determine the head lost in friction when water flows through a pipe 300 m long and 150 mm in diameter when the discharge of water through the pipe is 3000 litres/mini. Assume Darcy's friction co-efficient, $f = 0.01$.
- iii. An oil of kinematic viscosity 0.4 stoke is flowing through a pipe of diameter 300mm at the rate of 300 litres/s. Find the head lost due to friction for a length of 50 m of the pipe.
- iv. Calculate the discharge through a pipe of diameter 200 mm when the difference of pressure head between the two ends of a pipe 500 m apart is 4 m of water. Take $f = 0.009$.
- v. Find the loss of head due to friction in a pipe of 100 m length and 180 mm diameter, when the velocity of water in the pipe is 1.4 m/s. Also find the discharge through the pipe. Take Chezy's constant as 55.

3 RD
SEM

STRUCTURAL MECHANICS

SUBJECT CODE –(220732)

BY – SHIVA KHANDELWAL



STRESSES AND STRAINS

1.1 LOAD

Any external force acting on a body is called load. The unit of load are same as that of force. Load is measure in **Newton (N)**

1.2 CLASSIFICATION OF LOAD

1. According to the effect produced on the body:

- i. **Tensile load:** the load whose effect is to increase the length of the body in the direction of its application is known as tensile load.
- ii. **Compressive load:** the load whose effect is to decrease the length of the body in the direction of its application is known as compressive load.
- iii. **Shearing load:** the load whose effect is to cause sliding of one face of the body relative to the other is called shearing load.
- iv. **Bending load:** the load whose effect is cause a certain degree of curvature or bending in the body is called bending load.
- v. **Twisting load:** the effect produced by two couples applied at opposite ends of the body so as to cause one end to rotate about its longitudinal axis relative to the other end are called twisting load.

2. According to the manner of application of load on the body:

- i. **Dead load:** these load are also known as static load. Magnitude, direction and point of application of these loads are fixed for a given member.
- ii. **Live load:** these load are also known as fluctuating load. Magnitude, direction and point of application of these load are not fixed for a given member.

1.3 STRENGTH

The strength of a material may be defined as the maximum resistance which a material can offer to the externally applied load.

1.4 STRESS

Stress may be define as the internal resistance per unit area of cross-section offered by a body against the deformation.

$$\sigma = \frac{F}{A}$$

σ = stress induced in the body

P = load or force acting on a body

A = cross-sectional area of the body

1.5 TYPES OF STRESSES

1. **Direct stress:** when a force is applied perpendicular to the cross-section of the member the stress induced is known as direct stress.
 - i. **Tensile stress:** when an axial pull is applied on the cross-section area of a body, the stress induced is known as tensile stress.

- ii. **Compressive stress:** when an axial push is applied on the cross-sectional area of a body, the stress induced is known as compressive stress.
- 2. **Shear stress:** when two equal and opposite forces are applied tangentially to the cross section of a body, the stress induced is known as shear stress.

1.6 STRAIN

Strain may be defined as the ratio of change in dimension of the body to the original dimension of the body. Strain is denoted by Epsilon

$$\text{strain} = \frac{\text{change in dimension}}{\text{original value of dimension}}$$

1.7 types of strains

1. **Tensile strain:** the ratio of increased in length to the original length of the member is termed as tensile strain.
2. **Compressive strain:** the ratio of decrease in length to the original length of the member is termed as compressive strain.
3. **Shear strain:** the ratio of angular deformation to original length along the force is termed as shear strain.
4. **Volumetric strain:** the ratio between the change in volume and the original volume of a member is known as volumetric strain or bulk strain.

1.8 ELASTICITY AND ELASTIC LIMIT

- i. **Elasticity:** the deformation produce by external force do not disappear after the removal of external forces, such material are called plastic material
- ii. **Elastic limit:** the value of stress corresponding to this limiting force upto which the material is perfectly elastic is known as elastic limit

1.9 HOOKE'S LAW

This law states that when a material is loaded within limit of proportionality, the strain is directly proportional to stress produced by stress

$$\sigma \propto \epsilon$$

$$\sigma = E\epsilon$$

$$E = \frac{\sigma}{\epsilon}$$

1.10 LASTIC CONSTANTS

1. **Modulus of elasticity :** It may defined as the ratio of tensile stress and tensile strain or ratio of compressive stress and compressive strain. It is denoted by E.

$$E = \frac{\sigma}{\epsilon}$$

- 2. Modulus of rigidity:** the ratio of shear stress and shear strain is known as modulus of rigidity or shear modulus. This is denoted by G

Modulus of rigidity = shear stress/shear strain

- 3. Bulk modulus:** when a body is subjected to three mutually perpendicular normal stresses of equal intensity, the ratio of normal stress to the corresponding volumetric strain is known as bulk modulus. It is denoted by K .

$K = \text{Normal stress/volumetric strain}$

1.11 LONGITUDINAL STRAIN AND LATERAL STRAIN

Longitudinal strain: the strain along the direction of the applied force is known as longitudinal strain.

Lateral strain: The strain at right angles to the direction of applied force is known as lateral strain.

1.12 POISSON'S RATIO

The ratio of lateral strain to the longitudinal strain is known as poisson's ratio. It is denoted by $1/m$

Poisson's ratio = lateral strain /longitudinal strain

1.13 ENSILE TEST FOR DUCTILE METALS

- 1. Limit of proportionality:** limit of proportionality may be defined as that stress at which the stress-strain curve begins to deviate from the straight line.
- 2. Elastic limit:** Elastic limit may be defined as the stress developed in the material without any permanent deformation.
- 3. Yield point:** the stress corresponding to yield point is known as yield point stress.
- 4. Ultimate stress:** the stress attains its maximum value and is known as ultimate stress.
- 5. Breaking stress:** the stress corresponding to point F is known as breaking stress.

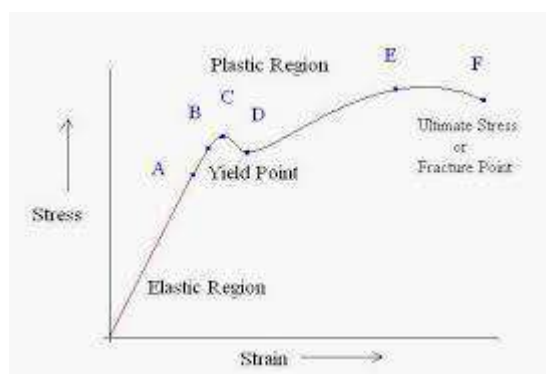

1.14 PROOF STRESS

Proof stress is the stress necessary to cause a permanent extension equal to a defined percentage of gauge length.

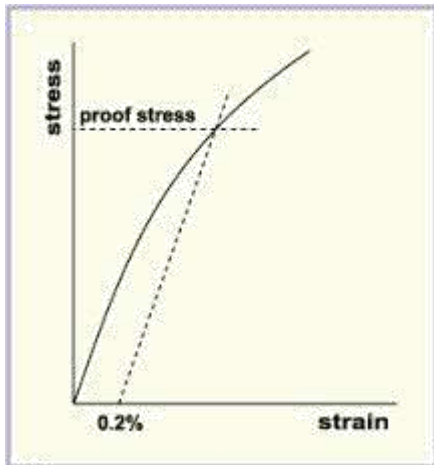

1.15 MAXIMUM OR ULTIMATE TENSILE STRESS

It is defined as the ratio of the maximum load to which a specimen is subjected in a tensile test and the original cross-sectional area of the specimen.

Ultimate stress = maximum load/original cross-sectional area

1.16 WORKING STRESS

The material is not subjected upto ultimate stress, but only upto a fraction of ultimate stress. This stress is known as working stress.

Working stress = ultimate stress/factor of safety

1.17 FACTOR OF SAFETY

The ratio of ultimate stress and working stress is known as factor of safety.

Factor of safety = ultimate stress/working stress

Factor of safety depend upon the following factors:

1. Types of load
2. Frequency of vibration of load
3. Degree of safety required
4. Degree of economy required
5. Dependability of the structure
6. Life span of the structure

1.18 BREAKING STRESS

It may be defined as the ratio of load at the time of fracture and the original cross-sectional area.

Breaking stress = load at breaking point/original cross sectional

area 1.19 YIELD STRESS

It may be defined as the lowest stress at which extension of the test specimen takes place without increase in load.

Yield stress = load at yield point/original cross-sectional area

1.20 MECHANICAL PROPERTIES OF MATERIALS

1. Elasticity/Stiffness

This is a measure of elastic deformation of a body under stress which is recovered when the stress is released. The ratio of stress to strain in the elastic region is known as stiffness or modulus of elasticity (Young's Modulus). When the stress goes beyond the elastic limit the material will no longer return completely to its original dimension.

2. Yield (or Proof Strength)

Stress needed to produce a specified amount of plastic or permanent deformation. (Usually a 0.2 % change in length)

3. Ultimate Tensile Strength (UTS)

The maximum stress a material can withstand before fracture.

4. Ductility

The amount of plastic deformation that a material can withstand without fracture.

5. Hardness

The resistance to abrasion, deformation, scratching or to indentation by another hard body. This property is important for wear resistant applications.

6. Toughness

This is commonly associated with impact loading. It is defined as the energy required to fracture a unit volume of material. Generally, the combination of a high UTS and a high ductility results in a higher toughness.

7. Fatigue Strength and Endurance Limit

Fatigue failure results from a repeated cyclic application of stress which may be below the yield strength of the material. This is known to be the most common form of mechanical failure of all engineering components. The number of stress cycles needed to cause fatigue failure depends on the magnitude of the stress. Below a certain stress level material does not fail regardless to the number of cycles. This is known as endurance limit and is an important parameter in many design applications.

8. Creep Resistance

The plastic deformation of a material which occurs as a function of time when the material is subjected to constant stress below its yield strength. For metals this is associated with high temperature applications but polymers may exhibit creep at low temperatures.

RESILIENCE

2.1 IMPORTANT TERMS

1. **Strain energy:** the work done in straining the body within the elastic limit is known as strain energy

$$\text{Strain energy} = \text{work done}$$

2. **Resilience:** It is a common term used for the total strain energy stored in a body. Sometimes, the resilience may be defined as the capacity of a strained body for doing work on the removal of the straining force.
3. **Proof resilience:** The maximum strain energy which can be stored in a body upto the elastic limit is called proof resilience.
4. **Modulus of resilience:** proof resilience per unit volume the body is known as modulus of resilience.

$$\text{Modulus of resilience} = \text{proof resilience}/\text{volume of the body}$$

5. **proof load:** the maximum load which can be applied to a body without its permanent deformation is called proof load.

2.2 TYPES OF LOADING

1. Gradually
2. Suddenly
3. With impact

2.3 STRAINED ENERGY STORED IN A BODY DUE TO GRADUALLY APPLIED LOAD

A Gradually applied load is that which is applied gradually on the body i.e. loading begins from zero and increase gradually till the body is fully loaded.

Let us consider a body which is subjected with tensile load which is increasing gradually up to its elastic limit from value 0 to value P and therefore deformation or extension of the body is also increasing from 0 to x and we can see it in following load extension diagram as displayed here.

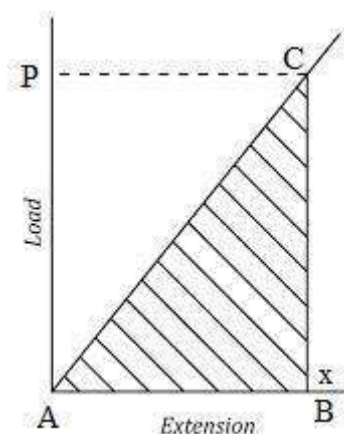

We have following information from above load extension diagram for body which is subjected with tensile load up to its elastic limit.

σ = Stress developed in the body

E = Young's Modulus of elasticity of the material of the body
 A = Cross sectional area of the body

P = Gradually applied load which is increasing gradually up to its elastic limit from value 0 to value P

$P = \sigma \cdot A$

x = Deformation or extension of the body which is also increasing from 0 to

x L = Length of the body

V = Volume of the body = $L \cdot A$

U = Strain energy stored in the body

Let use the value of the extension or deformation " x " in strain energy equation and we will have

$$U = (1/2) (\sigma \cdot L / E) \cdot \sigma \cdot A$$

$$U = (1/2) (\sigma^2 / E) L \cdot A$$

$$U = (\sigma^2 / 2E) V$$

$$U = (\sigma^2 / 2E) V$$

Therefore strain energy stored in a body, when load will be applied gradually, will be given by following equation.

$$\frac{\sigma^2}{2E} \times V$$

$$\text{Proof resilience} = \frac{\sigma^2}{2E} \times V$$

Modulus of resilience

Modulus of resilience = Proof resilience/Volume of the body

$$\text{Modulus of resilience} = \frac{\sigma^2}{2E}$$

2.4 STRAIN ENERGY IN A BODY DUE TO SUDDENLY APPLIED

LOAD A Load applied suddenly on a body is called suddenly applied load.

Let us see the load extension diagram as displayed here for this case where body will be subjected with sudden load and we will find out here the stress induced in the body due to sudden applied load and simultaneously we will also secure the expression for strain energy for this situation.

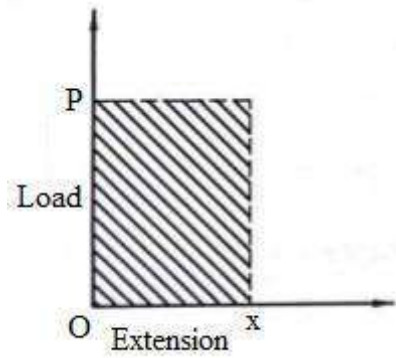

Let us go ahead step by step for easy understanding, however if there is any issue we can discuss it in comment box which is provided below this post.

We have following information from above load extension diagram for body which is subjected with sudden applied load.

σ = Stress developed in the body due to sudden applied load

E = Young's Modulus of elasticity of the material of the

body A = Cross sectional area of the body

P = Sudden applied load which will be constant throughout the deformation process of the body

x = Deformation or extension of the

body L = Length of the body

V = Volume of the body = $L.A$

U = Strain energy stored in the body

Strain energy stored in the body = Work done by the load in deforming the

body Strain energy stored in the body = Area of the load extension curve

Strain energy stored in the body = $P \cdot x$

$x U = P \cdot x$

As we know that maximum strain energy stored in the body U will be provided by the following expression as mentioned here.

$$U = \frac{\sigma^2}{2E} \times V$$

$$U = \frac{\sigma^2}{2E} \times A \cdot L$$

$$P \cdot x = \frac{\sigma^2}{2E} \times A \cdot L$$

Let use the value of the extension or deformation "x" in above equation and we will have

$$P \times \frac{\sigma}{E} \times L = \frac{\sigma^2}{2E} \times A \cdot L$$

$$P = \sigma \times A / 2$$

$$\sigma = 2P/A$$

2.5 STRAIN ENERGY STORED IN A BODY DUE TO IMPACT

LOAD A Load applied with some velocity is called impact load.

Let us see the following figure, where we can see one vertical bar which is fixed at the upper end and there is collar at the lower end of the bar. Let us think that one load is being dropped over the collar of the vertical bar from a height of h as displayed in following figure.

$$P \left(h + \frac{\sigma L}{E} \right) = \frac{1}{2} \cdot \frac{\sigma^2}{E} (A \times L)$$

$$Ph + \frac{P \cdot \sigma L}{E} = \frac{\sigma^2}{2E} (AL)$$

$$\frac{\sigma^2}{2E} - \frac{P \cdot \sigma}{A \cdot E} = \frac{P \cdot h}{A \cdot L}$$

$$\sigma^2 - \frac{2P\sigma}{A} = \frac{2PhE}{A \cdot L}$$

$$\sigma^2 - \frac{2P\sigma}{A} + \frac{P^2}{A^2} = \frac{2PhE}{A \cdot L} + \frac{P^2}{A^2}$$

$$\left(\sigma - \frac{P}{A} \right)^2 = \frac{P^2}{A^2} + \frac{2 \cdot P \cdot h \cdot E}{A \cdot L}$$

$$\left(\sigma - \frac{P}{A} \right) = \sqrt{\frac{P^2}{A^2} + \frac{2P \cdot h \cdot E}{A \cdot L}}$$

$$\sigma = \frac{P}{A} + \sqrt{\frac{P^2}{A^2} + \frac{2P \cdot h \cdot E}{A \cdot L}}$$

SHEARING FORCE AND BENDING MOMENT

A beam is a structure which is to carry all types of loading coming over it and is economically designed depending upon the type of loading, magnitude of loading and nature of support over which the beam rests.

NATURE OF SUPPORT

1. **Hinged Support:** In hinged support position of member is fixed but its direction is not fixed. It can offer resistance to the member horizontally and vertically



Hinged Support

2 Fixed Support: In fixed support, both position and direction of member are fixed. Reaction from the support can be any direction.



3 Simply Supported: In this case member rests freely over the support. The reaction will be normal to support. The position and direction are not fixed. Its horizontal component is assumed to be zero.

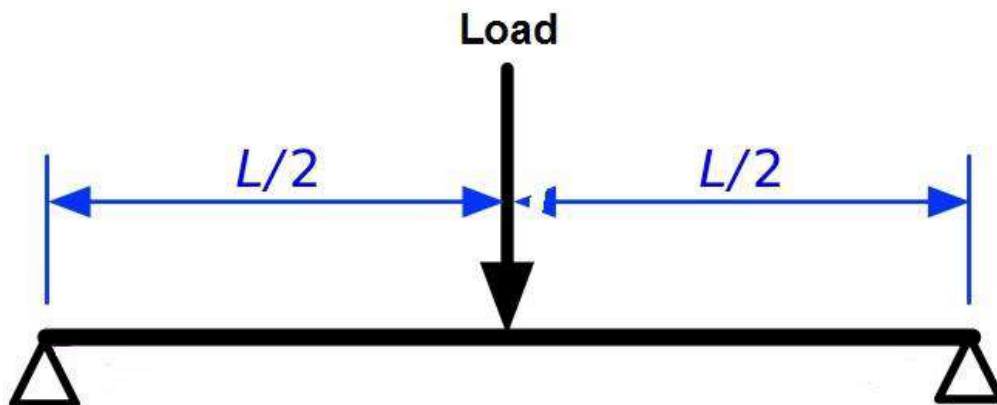

4. Roller Support: In this case reaction will always be normal to support and it does not offer any horizontal resistance, hence horizontal component is always zero.



TYPES OF BEAMS

1. **Cantilever:** A beam whose one end is firmly fixed and other end is free, is known as cantilever.

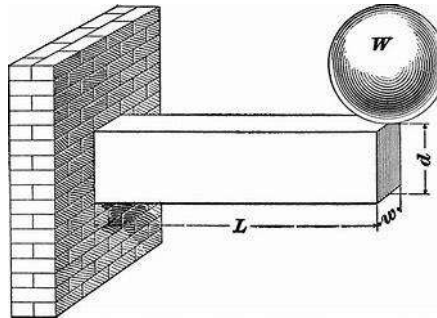

2. **Simply Supported Beam:** A beam whose both ends are simply resting on wall, columns etc. is called simply supported beam.

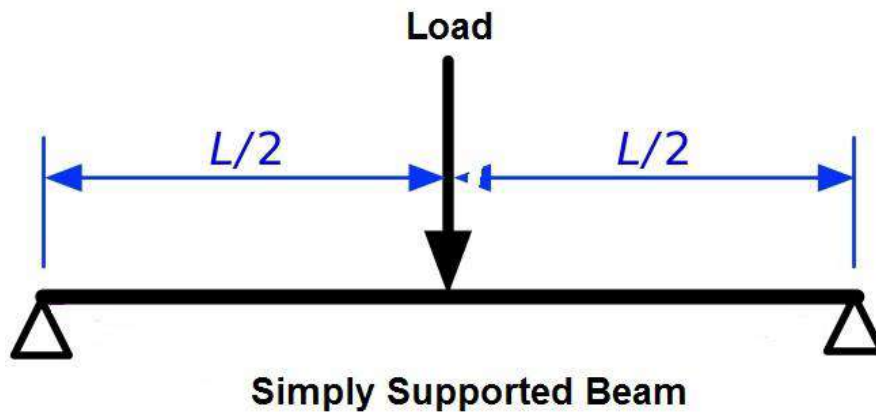

3. **Fixed Beam:** A beam whose both ends are firmly fixed in walls or columns is known as fixed beam.



Fixed Beam

4. **Continuous Beam:** A beam which has more than two support is known as continuous beam.

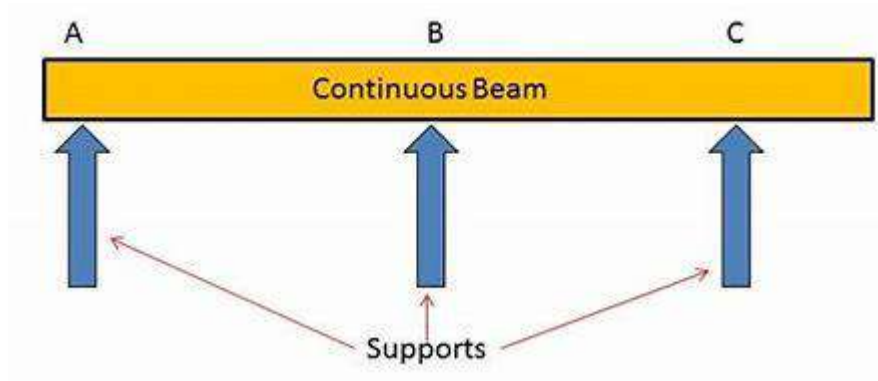

5 Overhanging Beams: When the supports are not at the ends of the beam or one or both the ends project beyond the support, then the beam is called overhanging beams.

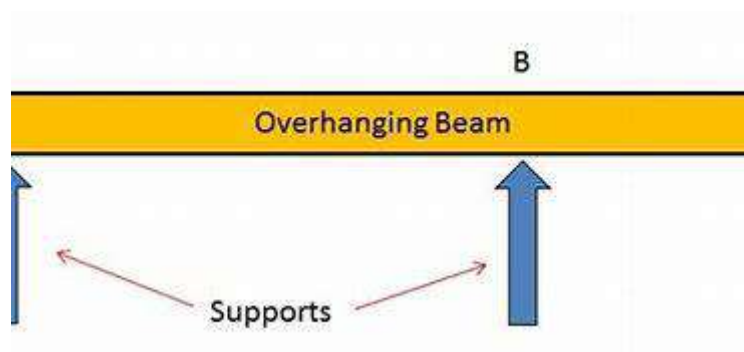

TYPES OF LOADING

1. **Concentrated or point load:** This type of load act on particular point of beam.

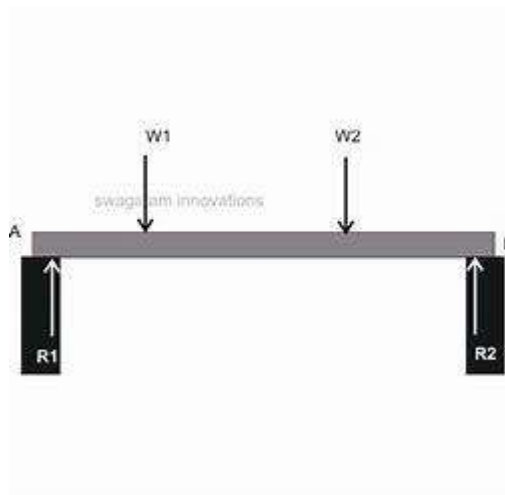

2. **Uniformly Distributed Load (U.D.L.):** This type of load is uniformly distributed over whole span of beam on or part of it. It is given in Newton/meter length.



3. **Varying Load:** If the intensity of load distribution increase from zero/unit length to a particular value (say) w /unit length uniformly. It is called varying load.

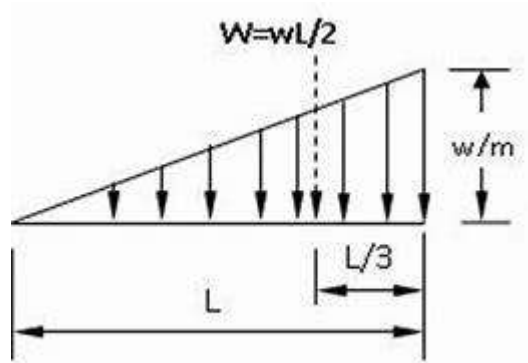

MOMENT OF INERTIA

MOMENT OF INERTIA

Moment of inertia (M.I) for a very small area about any axis is given by the product of area and square of distance between centroid of area and the given axis. This is also called second moment of the area.

$$\text{M.I.} = \text{Area} * (\text{distance})^2$$

THEOREM OF PERPENDICULAR AXIS

The moment of inertia of a plane of lamina about the perpendicular axis to its plane is equal to the sum of moments of inertia of plane of lamina about any two perpendicular axes intersecting each other at the point through which the perpendicular axis passes.

Perpendicular-axis theorem

The sum of the rotational inertia of a plane about any two perpendicular axes in the plane is equal to the rotational inertia about an axis through the point of intersection \perp the plane.

$$I_z = I_x + I_y$$

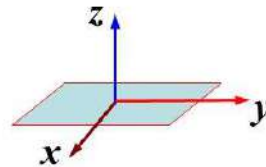

- 1) Only for **plane figures** or 2-dimensional bodies
- 2) $x \perp y \perp z$ and intersect at one point
- 3) Try to prove it by yourself

16

THEOREM OF PARALLEL AXIS

The moment of inertia (M.I.) of a plane of lamina about any axis is equal to its M.I. about a parallel axis passing through its centroid plus the product of the area of lamina and the square of the distance between two axes.

RADIUS OF GYRATION

The radius of gyration of an area is the distance from the centroid of the area to the

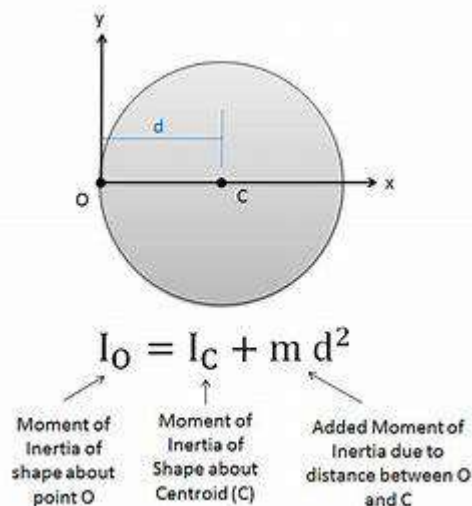

giv Consider a figure having area (A), moment of inertia (I) and centroid (G) en axis. It is denoted by K.

MOMENT OF INERTIA (M.I.) OF A CIRCULAR DISC

$$I_{zz} = D^4/32.$$

If I_{xx} = M.I. of disc about X-X axis.

I_{yy} = M.I. of disc about Y-Y axis.

By the theorem of - axis,

$$I_{zz} = I_{xx} + I_{yy}$$

$$I_{zz} = 2I_{xx}$$

$$I_{xx} - 1/2I_{zz} = D^4/64$$

$$I_{yy} = D^4/64$$

MOMENT OF INERTIA (M.I), OF A HOLLOW CIRCULAR DISC

$$I_{zz} = /32[D^4-d^4]$$

$$I_{xx} = /64[D^4-d^4]$$

$$I_{yy} = /64 [D^4 -d^4]$$

BENDING STRESSES

BENDING Equation:-

$$M/I=E/R$$

Hence $M/I=E/R=f/y$BENDING EQUATION

Where

M= B.M. or Moment of resistance of section

I= M.I. of the whole section about N.A.

E=Young's modulus of elasticity

R=Radius of curvature of N.A.

f= Bending stress at a distance y from N.A.

y=Distance of fibre from N.A.

APPLICATION OF BENDING EQUATION

The bending equation is authentic only for cases where there is pure Bending moment or there is no shearing force. Generally where shearing force is zero, the Bending moment is found to be maximum, in that case Bending equation holds correct results. The Bending Moment at a section accompanied by a shearing force can't be considered fairly correct for the application of Bending equations.

ASSUMPTIONS IN THE THEORY OF PURE BENDING

- 1 The material of the beam is homogenous or uniform throughout.
- 2 The material of the beam is isotropic i.e. having same elastic properties in all the directions.
- 3 The elastic limit remains within the permissible value.
- 4 The value of E (Young's modulus) remains same for tension and compression.
- 5 The transverse section of the beam remains plane before and after bending.
- 6 The resultant force on the transverse section of the beam is zero.
- 7 The beam is assumed to be straight initially.
- 8 Each layer of beam is free to expand or contract independently of the layers above and below it.
- 9 The application of load is only in the plane of bending.

Section Modulus (Z)

1. Rectangular Section

$$I = \frac{bd^3}{12}$$

$$y_{max} = \frac{d}{2}$$

$$Z = \frac{bd^2}{6}$$

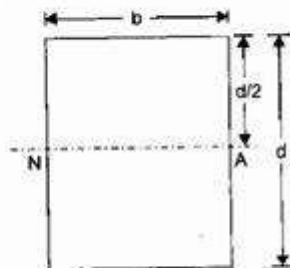

BENDING STRESSES

INTRODUCTION

When a section of beam is subjected to Bending moment, shear stresses and Bending stresses are set up in the beam. When there is no shearing force it can be considered as pure bending. These longitudinal bending stresses can either be compressive or tensile in nature.

BENDING EQUATIONS

M.I. of entire section of beam about N.A.

$$M/I = E/R.$$

Hence $M/I = E/R = f/y$

M = B.M. or Moment of resistance of section,

I = M.I of the whole section about N.A.

E = Young's modulus of elasticity,

R = Radius of curvature of N.A.,

F = Bending stress at a distance y from N.A.,

Y = Distance of fibre from N.A.

APPLICATION OF BENDING EQUATION

The bending equation is authentic only for cases where there is pure Bending moment or there is no shearing force. Generally where shearing force is zero, the Bending moment is found to be maximum, in that case Bending equation holds correct result. The Bending moment at a section accompanied by a shearing force can't be considered fairly correct for the application of Bending equations.

ASSUMPTION OF BENDING EQUATION

- 1.The material of the beam is homogeneous or uniform throughout.
- 2.The material of the beam is isotropic i.e. having same elastic properties in all the directions.
- 3.The elastic limit remains within the permissible value.
- 4.The value of E (Young's modulus) remains same for tension and compression.
- 5.The transverse section of the beam remains plane before and after bending.
- 6.The resultant Force on the transverse section of the beam is zero.
- 7.The beam is assumed to be straight initially.
- 8.Each layer of beam is free to expand or contract independently of the layers above and below it.
- 9.The application of load is only in the plane of bending.

Section Modulus (Z)

1. Rectangular Section

$$I = \frac{bd^3}{12}$$

$$y_{max} = \frac{d}{2}$$

$$Z = \frac{bd^2}{6}$$

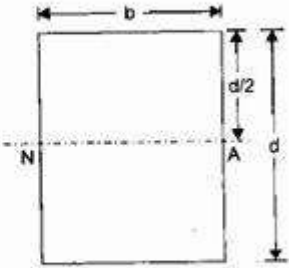

Section Modulus (Z)

3. Circular Section

$$I = \frac{\pi}{64} d^4$$

$$y_{max} = \frac{d}{2}$$

$$Z = \frac{\pi}{32} d^3$$

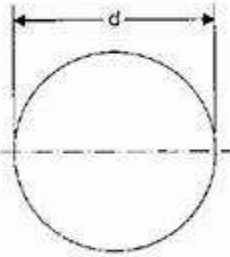

SHEAR STRESSES

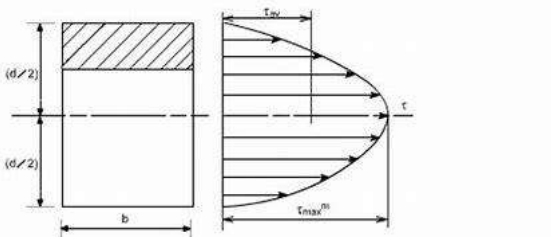

Shear stress is distributed parabolically across the rectangular section. Shear stress will be maximum at $y = 0$ and will be zero at the extreme ends.

and show the given shear stress distribution for a beam with circular cross-section (20 points)

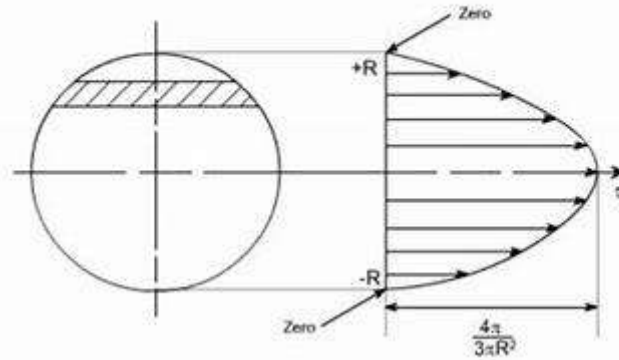

shear stresses of I section.

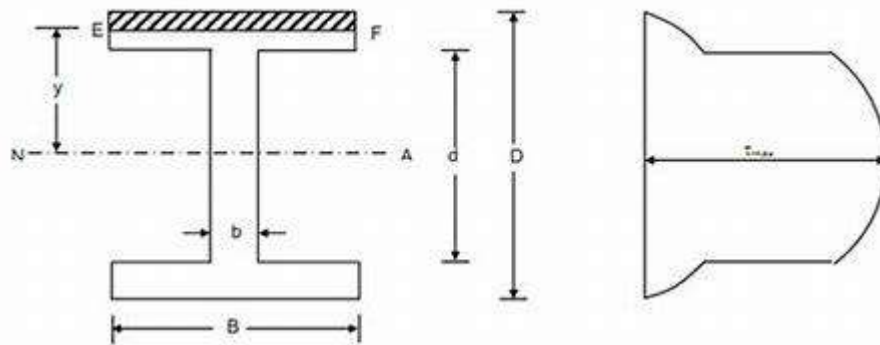

SLOPE AND DEFLECTION

DEFLECTION OF BEAM				
Sr No.	TYPE OF BEAM	MAX. BM	SLOPE	DEFLECTION
1		M	$\theta = \frac{ML}{EI} = \frac{PL}{EI}$	$\delta = \theta \times \frac{L}{2} = \frac{PL^2}{2EI}$
2		WL	$\theta = \frac{ML}{2EI} = \frac{WL^2}{2EI}$	$\delta = \theta \times \frac{2L}{3} = \frac{WL^3}{3EI}$
3		$\frac{WL}{2}$	$\theta = \frac{ML}{8EI} = \frac{PL}{8EI}$	$\delta = \theta \times \frac{3L}{4} = \frac{WL^4}{8EI}$
4		$\frac{WL^2}{3}$	$\theta = \frac{ML}{4EI} = \frac{WL^3}{24EI}$	$\delta = \theta \times \frac{4L}{5} = \frac{WL^4}{30EI}$
5		$\frac{WL}{4}$	$\theta = \frac{ML}{4EI} = \frac{WL^2}{16EI}$	$\delta = \theta \times \frac{L}{3} = \frac{WL^3}{48EI}$

SURVEYING-I

SUBJECT CODE – 220733

DO NOT COPY

BY – AVINASH SINGH YADAV

Surveying- 1



DEFINITION OF SURVEYING

Surveying is the art and science of determining the relative positions of various points or stations on the surface of the earth by measuring the horizontal and vertical distances, Angles and taking the details of these points and by preparing a map or plan to any scale.



★ Measurements taken in Horizontal and Vertical planes

Measurements

- Linear Measurement
- Angular Measurement

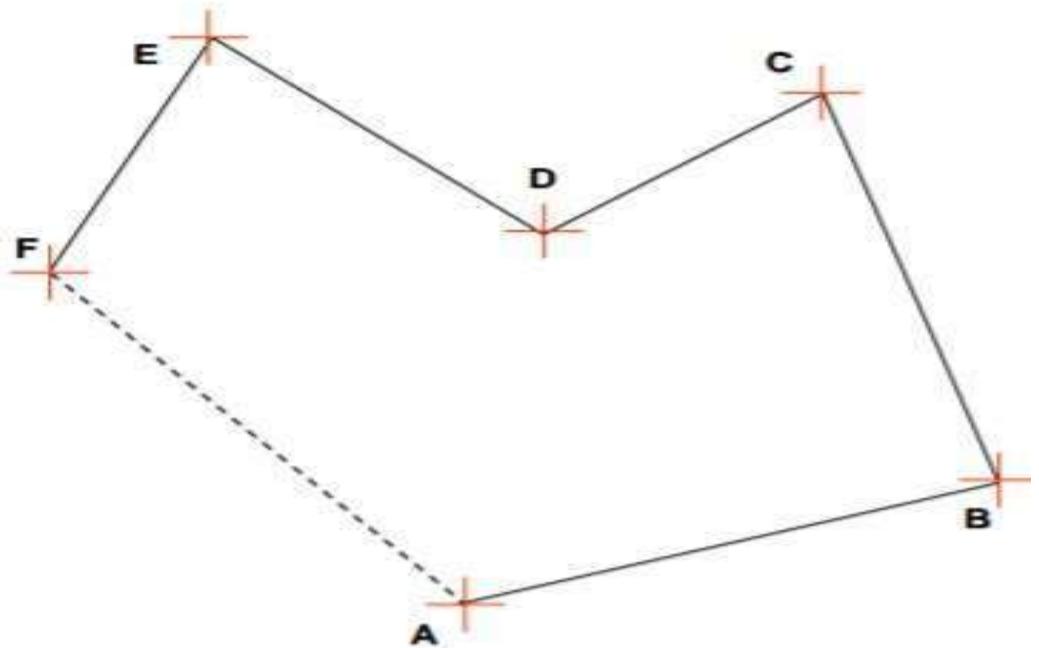

Fundamental principles of surveying

1. To work from **whole to part**
2. To fix or to locate a **new point** or station by **at least two independent measurements** or processes

whole to part

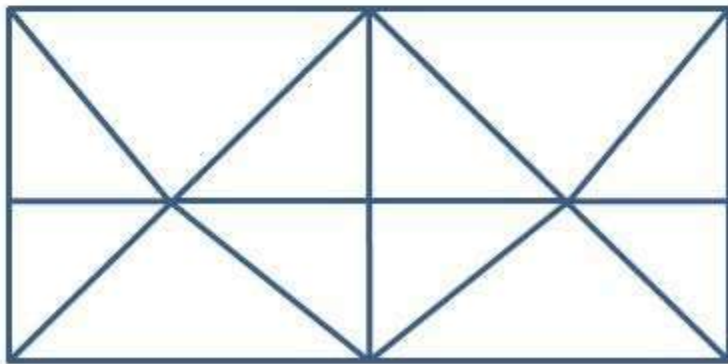

~~part to whole~~

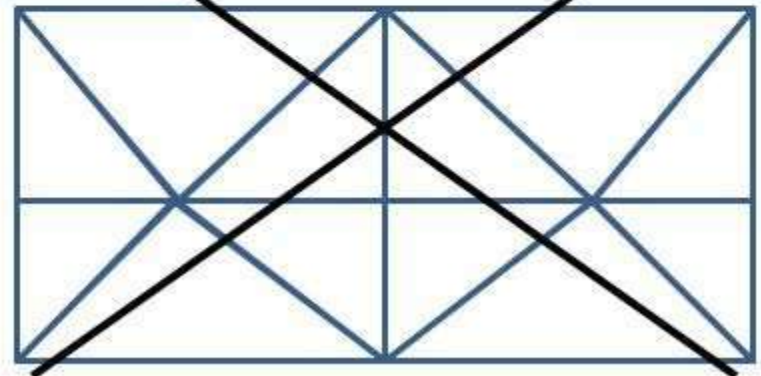

Chain surveying

OBJECTIVE: Study of various instruments used in chain surveying and their uses

INSTRUMENTS:

- 1) Chain or tape
- 2) Arrows
- 3) Ranging rods
- 4) Cross staff
- 5) Offset rods
- 6) Pegs
- 7) Plumb bob

Ranging

Ranging is essential step in chain surveying to ensure that measurements are made in a straight path along the survey line. If the end stations are inter-visible, direct ranging can be resorted.

Ranging are of two types:

- Direct Ranging
- Indirect Ranging

Operation in Chain Surveying

- Ranging
- Chaining
- Offsetting

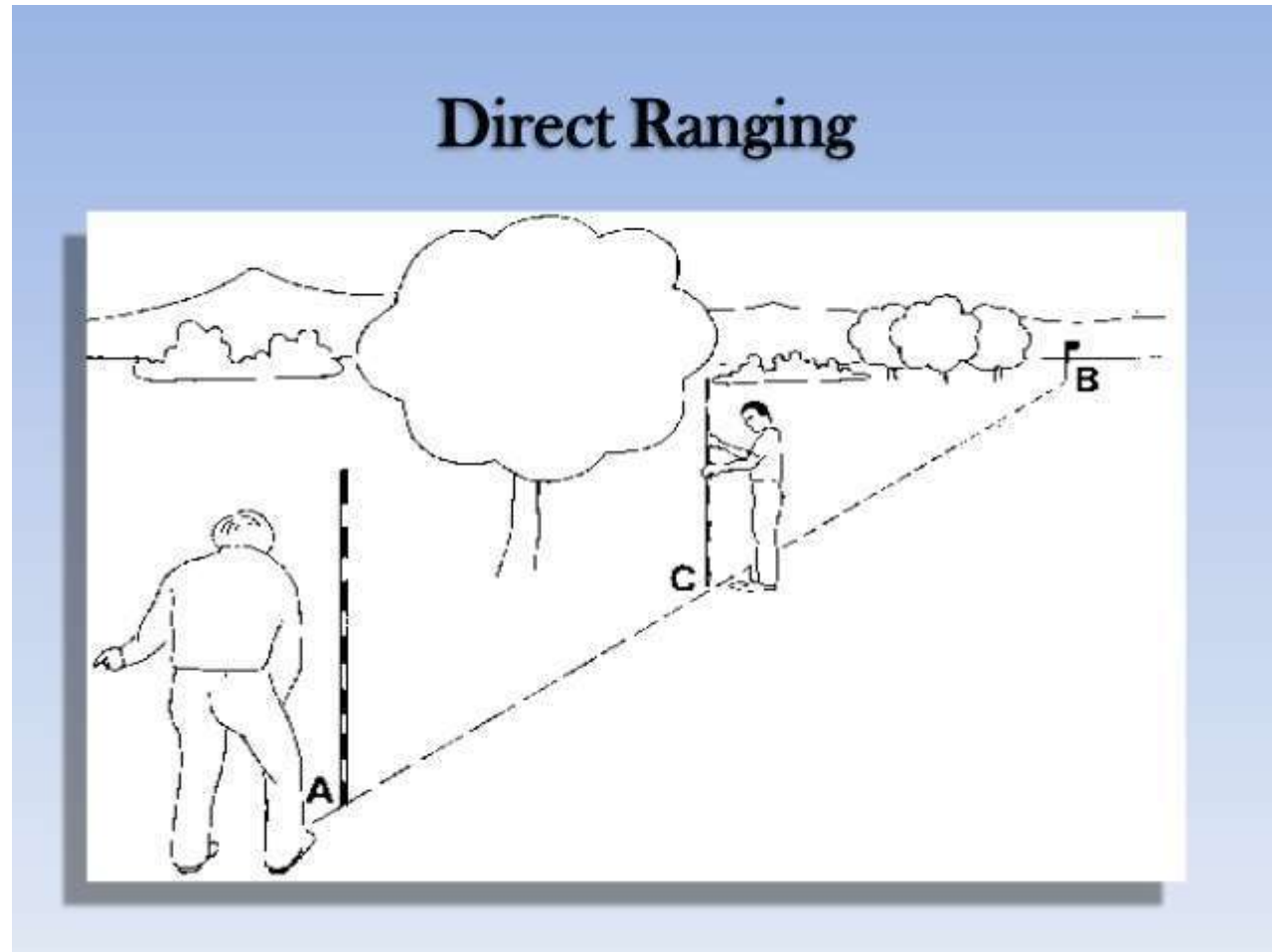

Types of Errors

```
graph TD; A([Types of Errors]) --- B([Instrumental Errors]); A --- C([Natural Errors]); A --- D([Personal Error]);
```

- Instrumental Errors

Natural Errors

Personal Error

ADVANTAGES OF CHAIN SURVEY



1. Is a simplest and commonest method used in surveying exercises.
2. The equipment used to conduct chain survey are simple to use.
3. The equipment used in chain survey can easily be replaced. For example measuring rods can be replaced with measuring tape.
4. This method does not involve complicated mathematical calculation.
5. Enable us to make quick measurements of small areas of flat or nearly flat & associated objects.
6. Is applicable in adding new information to existing plans or large scale maps.
Example: adding the new details of National Stadium to existing map of Dar es Salaam City.
7. Is useful in planning (Eg. arrangement of rooms).
8. It is economical since it needs few people to conduct it (normally chain survey team has three people Booker, leader and follower).

Disadvantages:

- It cannot be used for large areas
- It cannot be used in thick bushy areas with ups and downs.
- Chain surveying is not always accurate.



What Is The Compass

A compass is an instrument designed for the measurement of directions with reference to the magnetic meridian.

The two main types of compass

- Prismatic compass
- Surveyor's compass

Compass Surveying

The Prismatic Compass

The prismatic compass is a magnetic compass which consists of the following parts.

Cylindrical Metal Box

Cylindrical metal box is having diameter of 8 to 12 cm. It protects the compass and forms entire casing or body of the compass. It protects compass from dust, rain etc.



Prismatic Compass

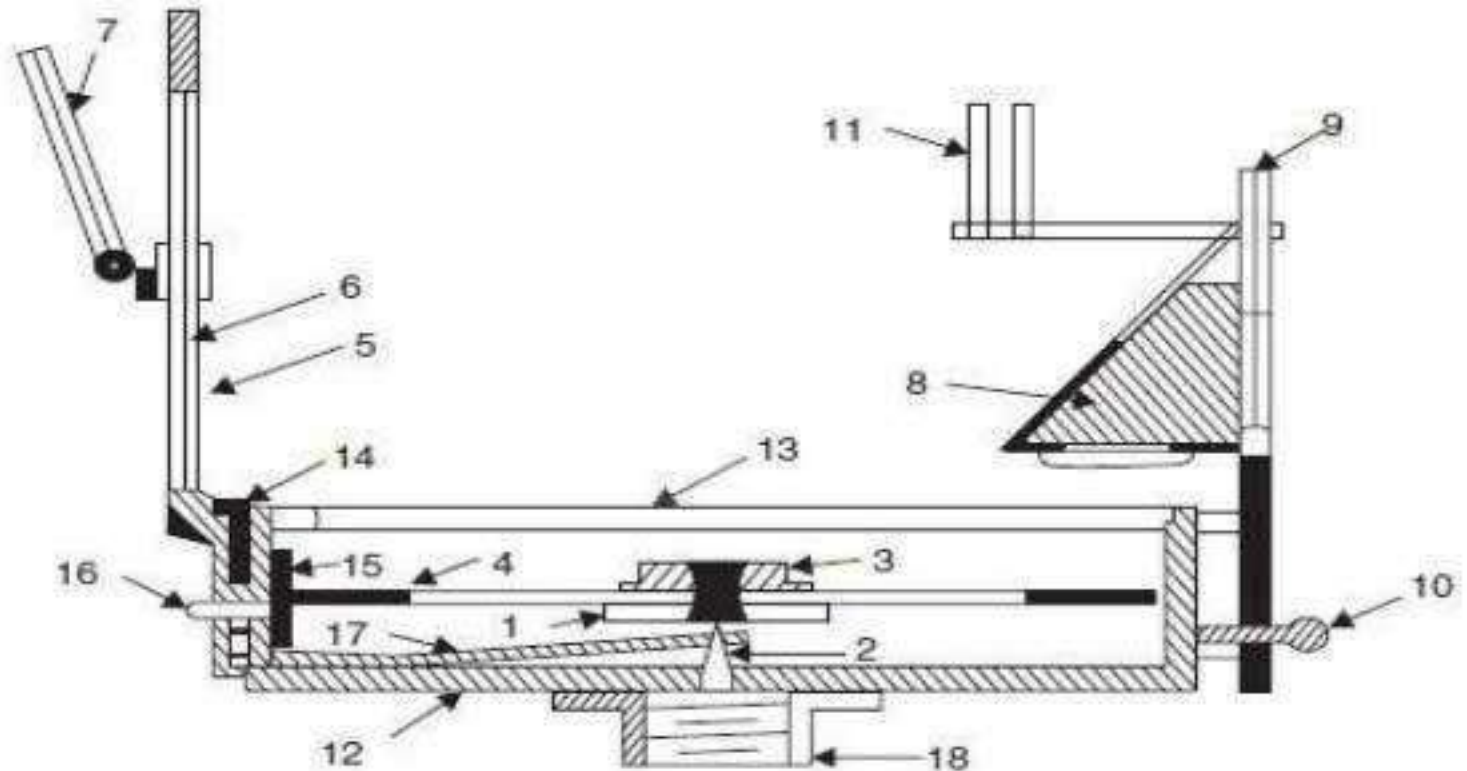

- | | |
|------------------------------|------------------------------|
| 1. Needle | 10. Focussing stud |
| 2. Pivot | 11. Dark sunglasses |
| 3. Agate cap | 12. Box |
| 4. Graduated disc | 13. Glass cover |
| 5. Slit metal frame | 14. Lifting pin |
| 6. Horse hair | 15. Light spring |
| 7. Mirror | 16. Brake pin or knob |
| 8. Reflecting prism with cap | 17. Lifting lever |
| 9. Eye vane | 18. Support to fit on tripod |

Prismatic compass

The Surveyor's Compass

Working of Surveyor's Compass:

- **Centering**
- **Levelling**
- **Observing the Bearing of a Line**
- First two operations are similar to that of prismatic compass but the method of taking observation differs from that.
- Observing the bearing of a line. In this type of compass, the reading is taken from the top of glass and under the tip of north end of the magnetic needle directly. No prism is provided here.



<i>Sr. No.</i>	<i>Prismatic Compass</i>	<i>Surveyors Compass</i>
1.	Graduation circle is fixed to broad type needle. Hence, it will not rotate with the line of sight.	Graduation circle is fixed to the box. Hence, it rotates with the line of sight.
2.	There is a prism at viewing end.	At viewing end there is no prism. There is only a slit.
3.	Sighting and reading can be done simultaneously.	Sighting and viewing cannot be done simultaneously.
4.	The magnetic needle do not act as an index.	Magnetic needle acts as index while reading.
5.	The graduations are in whole circle bearing.	The graduations are in quadrantal system.
6.	Graduations are marked inverted since its reflection is read through prism.	Graduations are marked directly. They are not inverted.
7.	The reading is taken through a prism.	The reading is taken by directly viewing from top glass.
8.	Tripod may or may not be used. It can be held on a stretched hand also.	Tripod is essential for using it.

Whole Circle Bearing System (W.C.B)

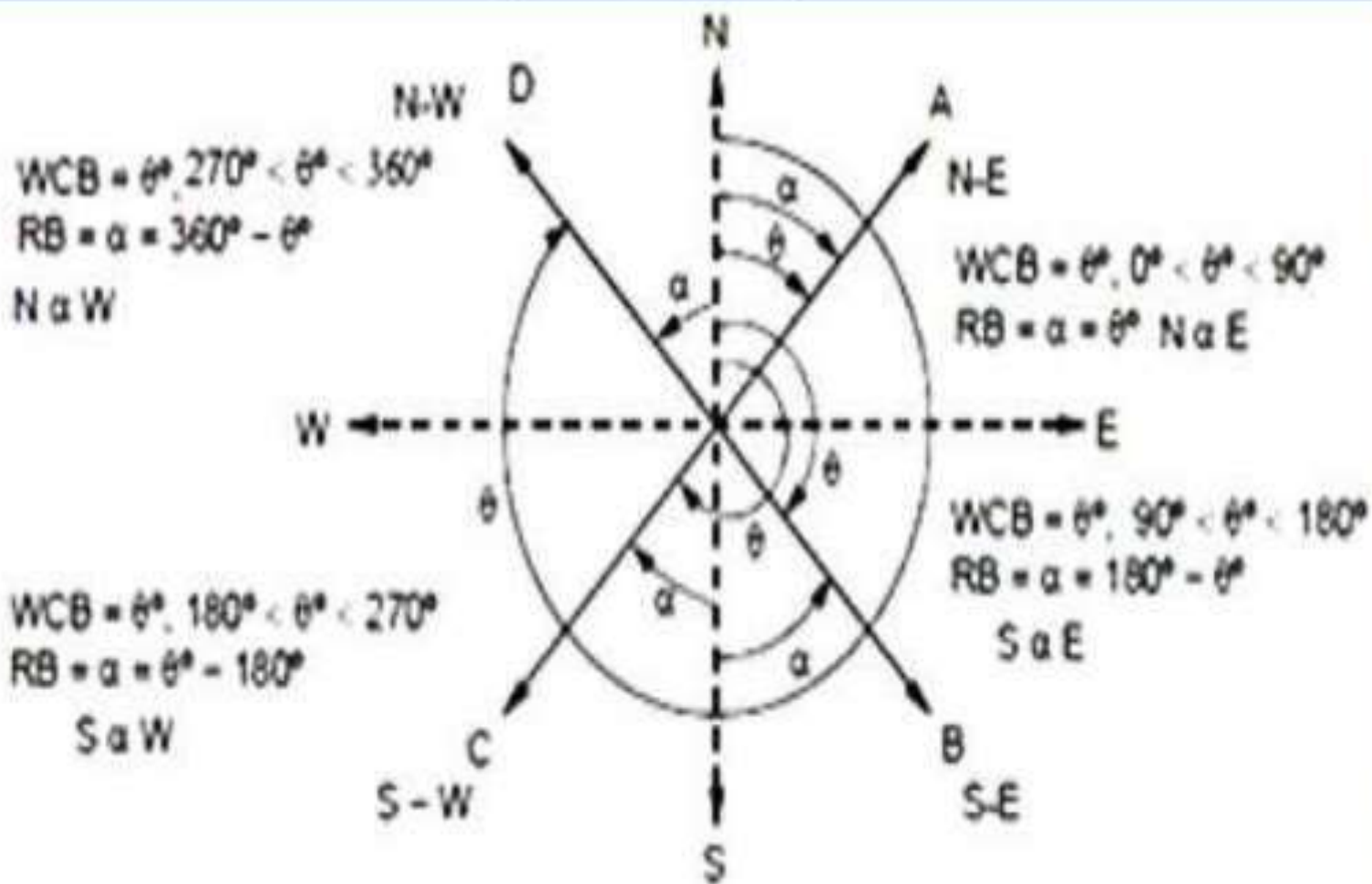

The Following Table Should be Remembered for Conversion of WCB to RB

Case	WCB between	R.B.	QUADRANT
1	0° TO 90°	WCB	N-E
2	90° TO -180°	$180 - \text{WCB}$	S-E
3	180° TO -270°	$\text{WCB} - 180^{\circ}$	S-W
4	270° TO 360°	$360 - \text{WCB}$	N-W

Fore bearing and Back bearing

The bearing of a line measured in the forward direction of the survey lines is called the 'fore bearing' (F.B.) of that line.

The bearing of a line measured in direction backward to the direction of the progress of survey is called the 'back bearing' (B.B.) of the line.

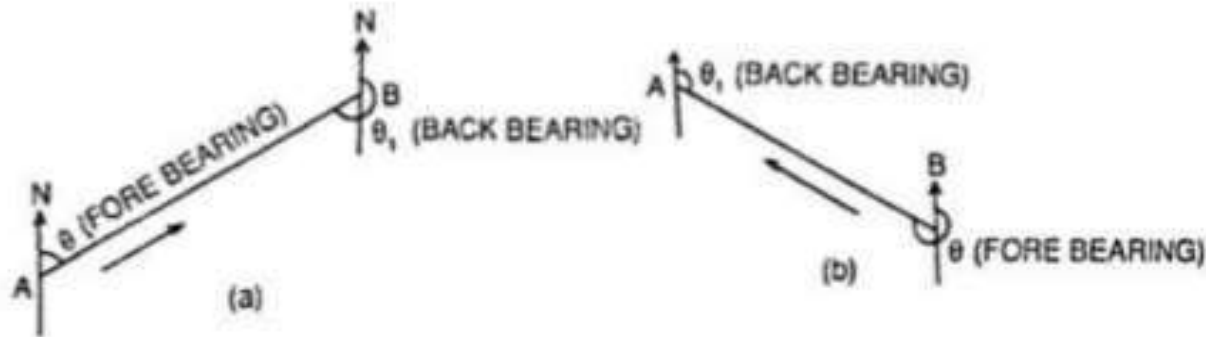

In WCB the difference between FB and BB should be exactly 180°

$$BB = FB \pm 180^\circ$$

Use the +ve sign when $FB < 180^\circ$

Use the -ve sign when $FB > 180^\circ$

Local Attraction

- ✱ may be **constant** or **may vary** depending upon the surrounding magnetic influences
- ✱ draws the needle **away** from the magnetic meridian

LEVELLING

LEVELLING

✓ According to science

- Leveling is a branch of surveying which deals with the measurement of relative heights of different points on, above or below the surface of the earth. Thus in leveling, the measurements (elevations) are taken in the vertical plane.

✓ Simple Definition

- Leveling is the process used to determine a difference in elevation between two points.

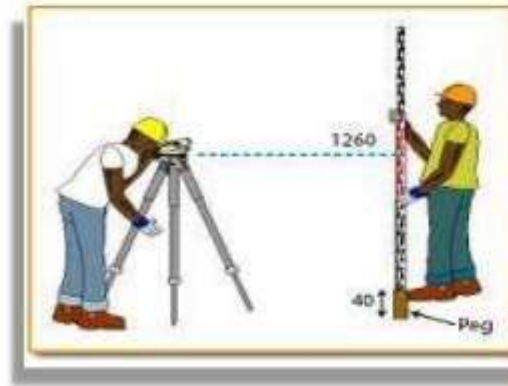

LEVELLING

Principle of levelling

- *Principle:- The principle of levelling is to obtain horizontal line of sight with respect to which vertical distances of the points above or below this line of sight are found.*

TYPES OF LEVELS:

- i) Dumpy level
- ii) Tilting level
- iii) Automatic level
- iv) Digital Auto level

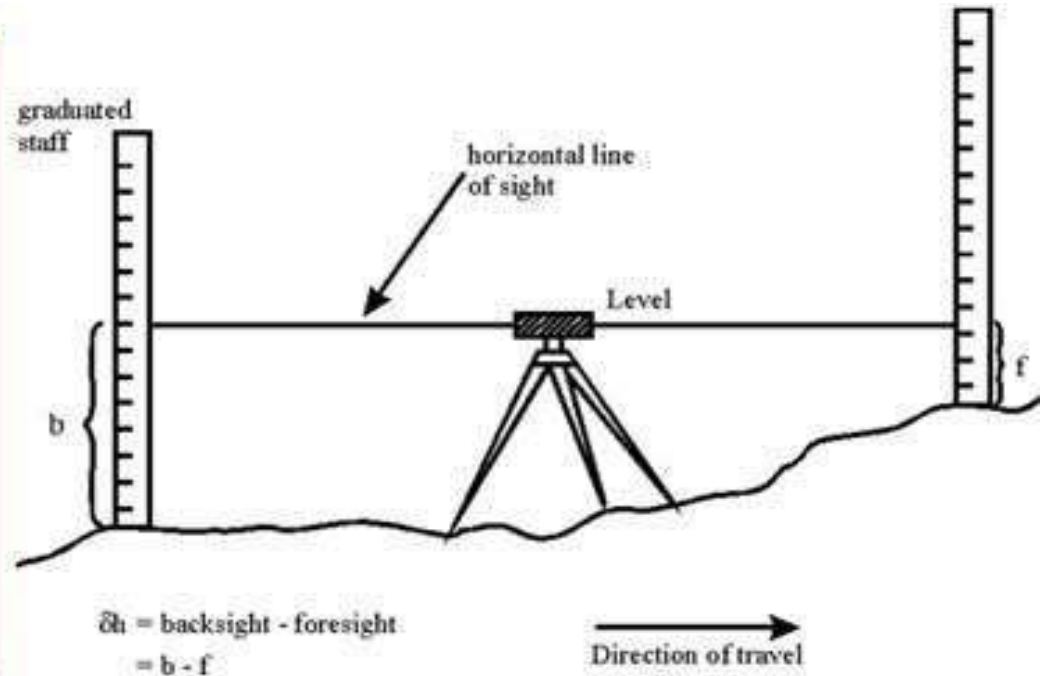
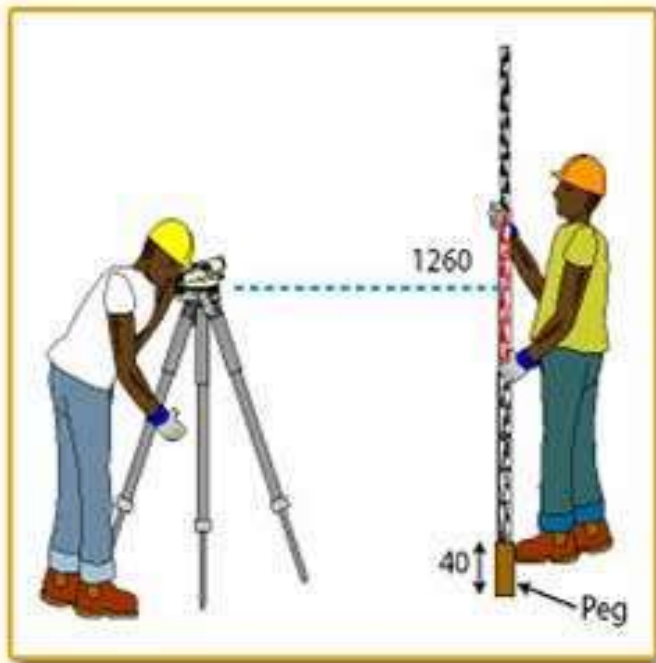

Reduction Of Level

- Height of Instrument Method
- Rise and Fall Method

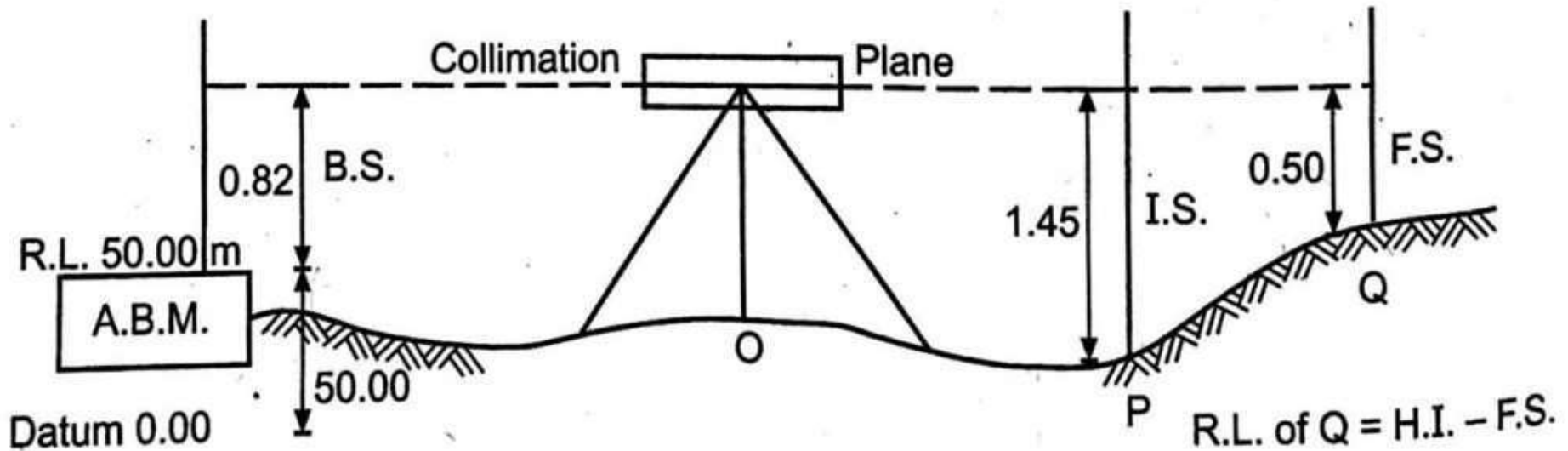

Sl.No	Height of collimation system	Rise and fall system
1	It is rapid as it involves few calculation	It is laborious involving several calculation
2	There is no check on the RL of the intermediate sight	There is a check on the RL of the intermediate points
3	Errors in the intermediate RLs cannot be detected.	Errors in the intermediate RLs can be detected as all the points are correlated
4	There are two checks on the accuracy of RL calculation	There are three checks on the accuracy of RL calculation
5	This system is suitable for longitudinal leveling where there are a number of intermediate sights	This system is suitable for fly leveling where there are no intermediate sights

Errors in Levelling

- Instrumental Error
- Personal Error
- Natural Error

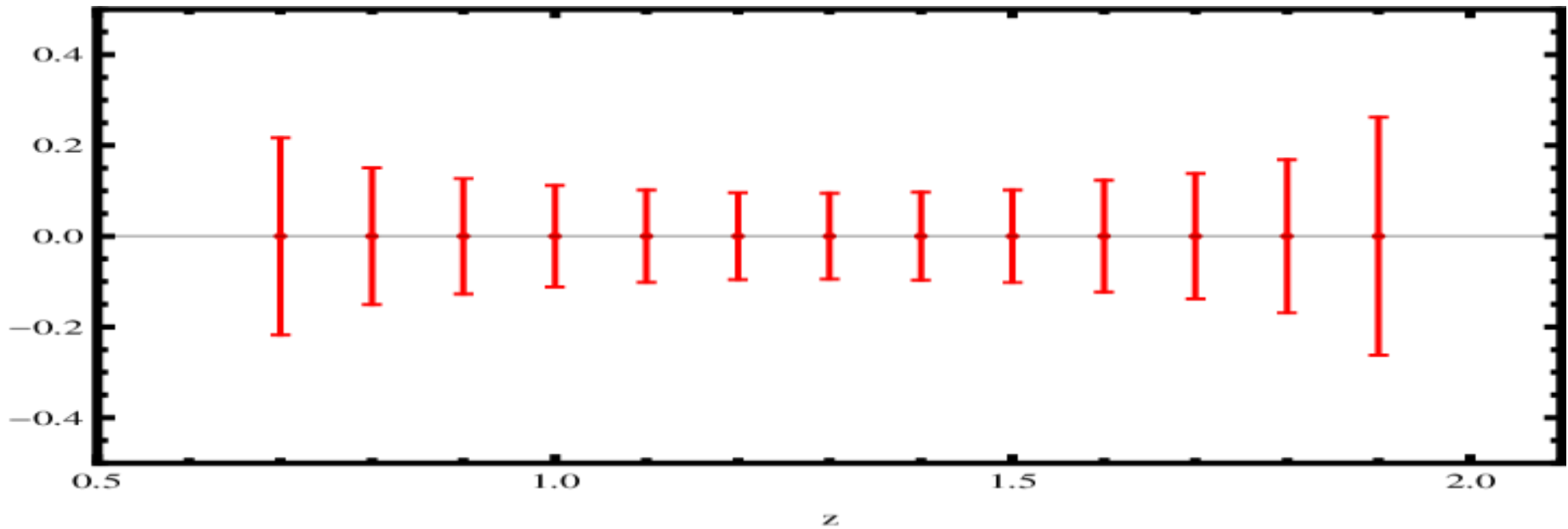

CONSTRUCTION TECHNOLOGY

SUBJECT CODE – 220731

DO NOT COPY

BY – PRADEEP KUMAR

Construction Material

Contents:

- Classification of stones
- Rocks & it's types
- Bricks & it's classification
- Cement & it's composition
- Paints and it's composition

- *Construction planning* is a fundamental and challenging activity in the management and execution of construction projects.

Classification of stones :

- The term rock is commonly defined as a hard mass of mineral matter having, as a rule, no definite external form.
- The word stone is applied indiscriminately to all classes of hard rocks.



Description of Classes:

Rocks are classified as follows:

1. According to geological origin-
Igneous, Sedimentary and Metamorphic
2. According to the physical form-
Stratified, Unstratified and Foliated.
3. According to their chemical composition-
Silicious, Argillaceous and Calcerous.



GEOLOGICAL CLASSIFICATION:

IGNEOUS ROCK:

- Igneous Rock, rock formed when molten or partially molten material, called magma, cools and solidifies. The inner layers of the earth are at a very high temperature causing the masses of silicates to melt.

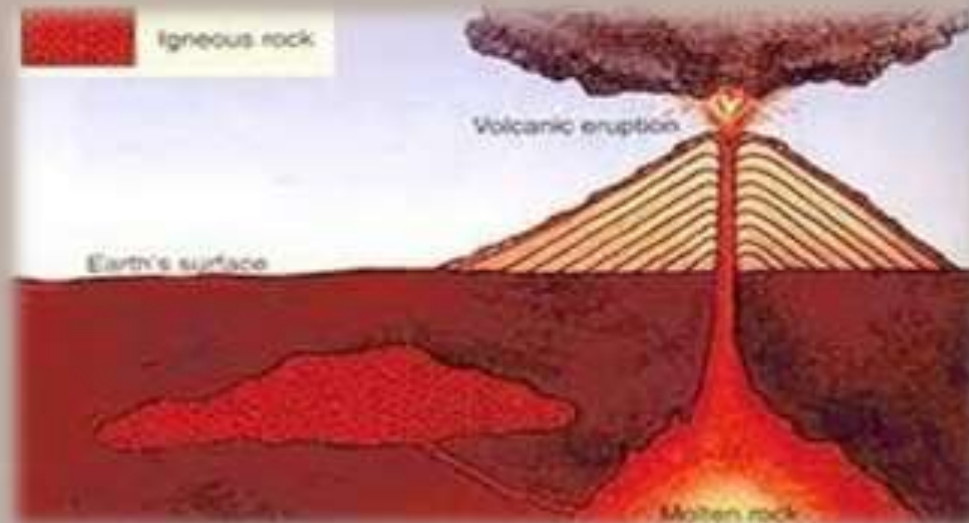

SEDIMENTARY ROCKS:

- Sedimentary rocks are types of rock that are formed by the deposition and subsequent cementation of that material at the Earth's surface and within bodies of water.

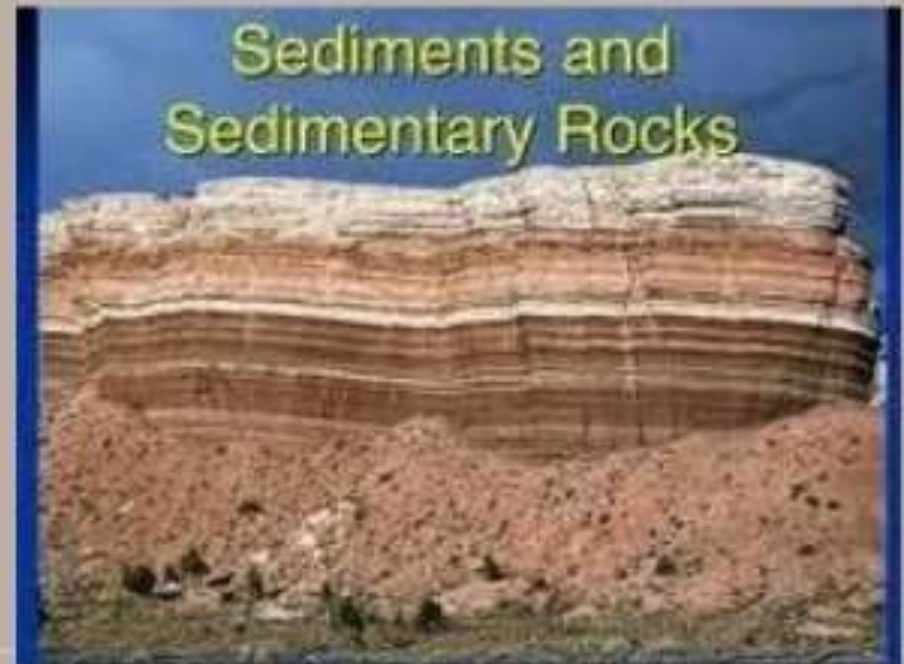
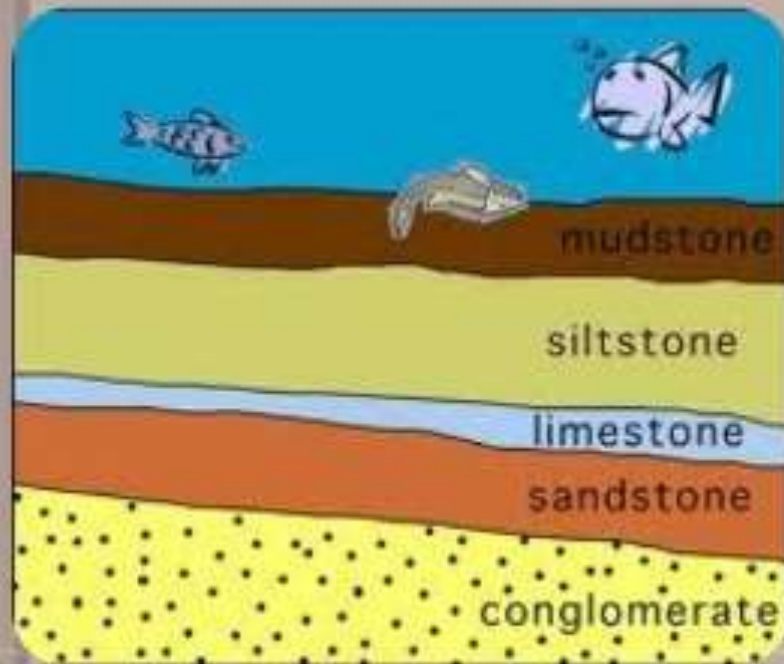

METAMORPHIC ROCKS:

- Metamorphic Rock is a type of rock formed when rocky material experiences intense heat and pressure in the crust of the earth. This change from one mineral assemblage to another is called metamorphism.

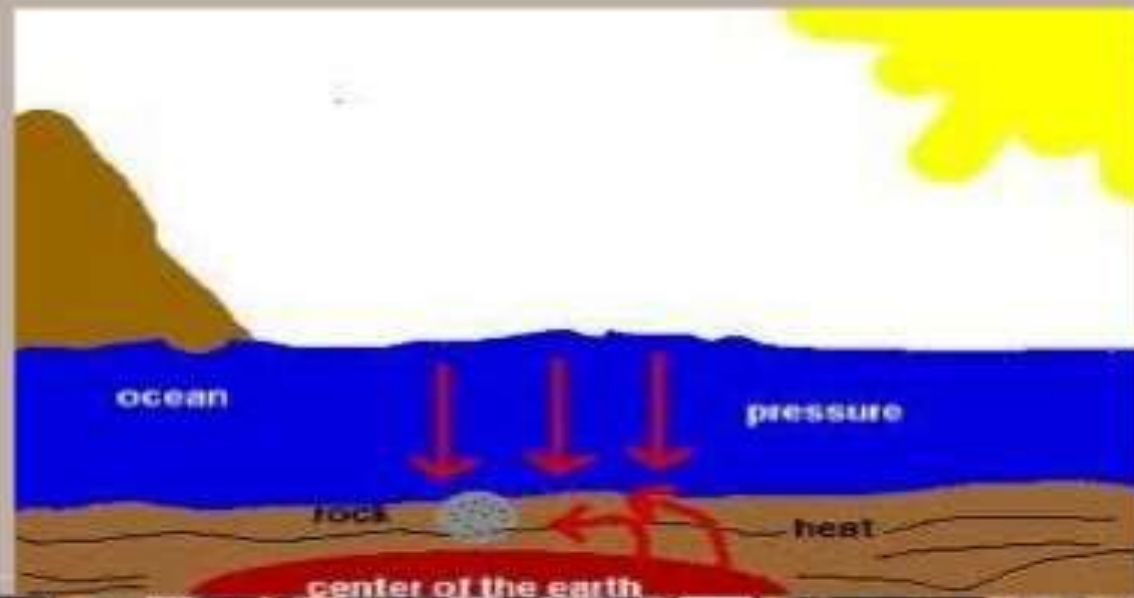

Physical Classification of Rocks:

Based on the structure, the rocks may be classified as:

1. Stratified rocks
2. Unstratified rocks



Stratified Rocks:

The layering that occurs in most sedimentary rocks and in those igneous rocks formed at the Earth's surface, as from lava flows and volcanic fragmental deposits. The layers range from several millimeters to many meters in thickness and vary greatly in shape



Unstratified:

These rocks are not stratified. They possess crystalline and compact grains. They cannot be split in to thin slab. Granite, trap, marble etc. are the examples of this type of rocks.



Foliated rocks:

Metamorphic rock is formed when existing rock (whether it is sedimentary, igneous, or another metamorphic rock) is changed by intense pressure and temperature. Typically, this happens deep within the Earth, or near volcanoes.

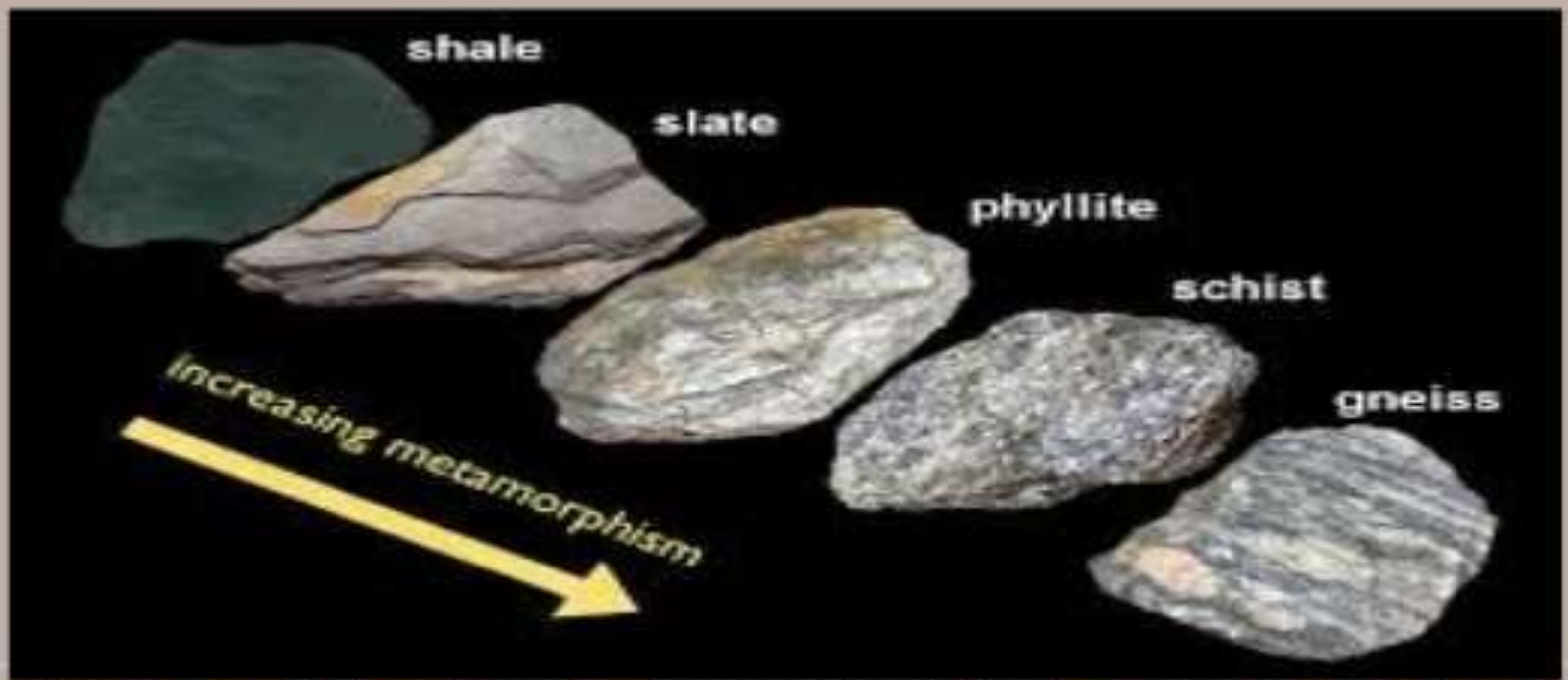



BRICKS

A small rectangular block typically made of fired or sun dried clay, used in building and other construction.

It Has Two Main Types On The Basis Of Size And Dimensions:-

- Modular Bricks
- Traditional Bricks



Traditional Bricks

The Dimension Of Traditional Bricks

Varies From 21 To 25 Cm In Length
&
From 10 To 30 Cm In Width
&
From 7.5 To 1 Cm In Height

Modular Bricks

Indian Standard Institution Has Suggested Uniform Brick Size Is Known As Modular Brick.

The Actual Size Is 19 × 9 × 9 Cm



Classification Of Bricks On The Basis Of Manufacturing Quality

1. First class bricks
2. Second class bricks
3. Third class bricks
4. Fourth class bricks

FIRST CLASS BRICKS

- **MADE OF GOOD EARTH WHICH IS FREE FROM SALINE DEPOSITS AND ARE SAND MOLDED.**
- **BURNT THOROUGHLY WITHOUT BEING VITRIFIED AND HAVE DEEP RED, CHERRY AND COPPER COLOR.**

SECOND CLASS BRICKS

- **They shall be well burnt or slightly over burnt.**
- **They must give clear ringing sound when struck.**
- **The may have slight irregularities in size, shape and color.**
- **The minimum crushing strength of second class brick should be 70 kg per sq cm**

THIRD CLASS BRICKS

- **THESE BRICKS ARE SLIGHTLY UNDER BURNT OR OVER BURNT.**
- **THEY ARE NOT UNIFORM IN SHAPE, SIZE AND EDGES.**
- **THEY SHALL NOT OBSERVE WATER MORE THAN 25% OF THEIR OWN DRY WEIGHT AFTER 24 HOURS, IMMERSION IN COLD WATER.**
- **THEY HAVE SOME SIGNS OF EFFLORESCENCE**

FOURTH CLASS BRICKS

- **These are over burnt bricks which are dark in colour and are irregular in size and shape.**
- **These are used as aggregate in concrete and for flooring.**
- **Over burnt bricks are not used for building construction**

Cement

- Binding Material
- Provide strength to concrete with a process called Hydration
- The ready mix of cement consist of silicate and aluminate of lime.
- Consist of seven major ingredients:-
 - A.) Hydrated Lime (60%-67%) CaO :- Provide strength and responsible for hydration
 - B.) Silica (17%-25%) SiO_2 :- Provide Strength to cement due to formation of dicalcium Silicate & tricalcium Silicate
 - C.) Alumina (3%-8%) Al_2O_3 :- Resistance against high temperature/control of temperature.
 - D.) Magnesia(0.1%-4%) MgO :- Responsible of Hardness
 - E.) Iron Oxide (0.5%-6%) Fe_2O_3 :-Responsible for Strength and Color of Cement
 - F.) Sulpher Trioxide (1%-2.25%) SO_3 :- Responsible of Setting time of Cement
 - G.) Alkalies (Soda and Potash):- 0.1% to 1%

Types of Cement

Type	Classification	Characteristics	Applications
Type I	OPC BS 81-197-1:2000 ASTM C-150-94	Fairly high C_3S content for good early strength development Not more than 10% by weight particles will retain on BS Sieve No. 170 Chemical composition: C_3S -tricalcium silicate-50% (Responsible for final setting time, produce heat) C_2S -dicalcium silicate-25% (Responsible for final setting time) C_3A -tricalcium aluminate-12% (Responsible for initial setting time and quick setting time, produce heat) C_4AF -tetracalcium aluminoferrite-8% (Responsible for initial setting time and quick setting time)	General construction (most buildings, bridges, pavements, precast units, etc)
Type II	Moderate sulfate resistance BS 81-197-1:2000 ASTM C-150	Low C_3A content (<8%) Chemical composition: C_3S -40% C_2S -29% C_3A -6% C_4AF -12%	Structures exposed to soil or water containing sulfate ions
Type III	Rapid Hardening Cement BS EN -197-1	Grind more finely, provide more heat with high temperature in factory may have slightly more C_3S Not more than 5% by weight particles will retain on BS Sieve No. 170 Chemical composition: C_3S -60% C_2S -12% C_3A -12% C_4AF -8%	Rapid construction, cold weather concreting
Type IV	Low heat of Hydration (slow setting) BS 1370-1979	Low content of C_3S (<30%) and C_3A (5%) More amount of C_2S Chemical composition: C_3S -30% C_2S -60% C_3A -5% C_4AF -12%	Massive structures such as dams. Now rare.
Type V	High sulfate resistance BS-4027-1996	Very low C_3A content (<5%) Chemical composition: C_3S -40% C_2S -36% C_3A -4% C_4AF -12%	Structures exposed to high levels of sulfate ions
White	White color	No C_3A , low MgO	Decorative (otherwise has properties similar to Type I)

Tests of Cement

A.) Fineness Test:- to check the particles grinding

Equipment used: BS Sieve No.170

B.) Consistency Test: To Check the %age of water required for Cement Paste

Equipment Used: Vicat Apparatus

C.) Setting Time Test: to check Initial and Final setting time of Cement

Equipment Used:- Vicat Apparatus

D.) Soundness Test: to check the changes in volume of cement paste after setting time.

Equipment Used: Le Chateller Apparatus

E.) Compression Test

F.) Tensile Test

Values for Compression strength of Cement

- Ordinary Portland Cement

3 Days= 112.7 kg/m²

7 Days=176 kg/m²

- Rapid Hardening Cement

3 Days= 211.3 kg/m²

7 Days=264.1 kg/m²

Values for Tensile strength of Cement

- Ordinary Portland Cement

3 Days= 21 kg/m²

7 Days=26 kg/m²

- Rapid Hardening Cement

3 Days= 21 kg/m²

7 Days=32 kg/m²

PAINT

- **WHAT IS PAINT??** **S**
- THE PAINTS ARE COATING OF FLUID MATERIAL AND THEY ARE APPLIED OVER THE SURFACE OF TIMBER AND METALS.
- PAINT IS A LIQUID COMPOSITION AFTER APPLICATION IT IS CONVERT IN TO A SOLID FILM.



COMPOSITION:-

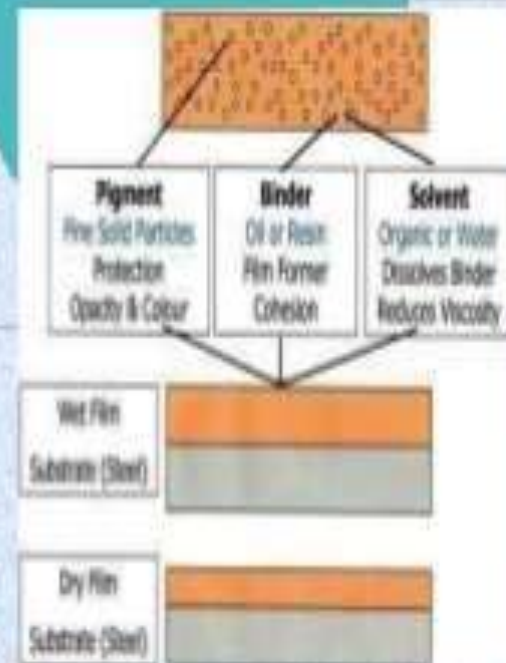
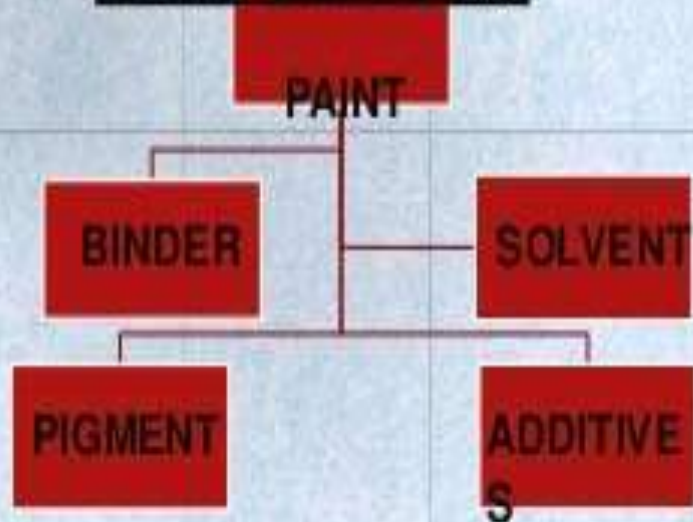

BASE

- ✓ Principle constituent
- ✓ A metallic oxide
- ✓ Makes the paint film opaque.
- ✓ Possesses binding properties which helps reduce shrinkage cracks on drying.
- ✓ E.g.,:- white lead, red lead, zinc white, aluminium powder, iron oxide etc.,

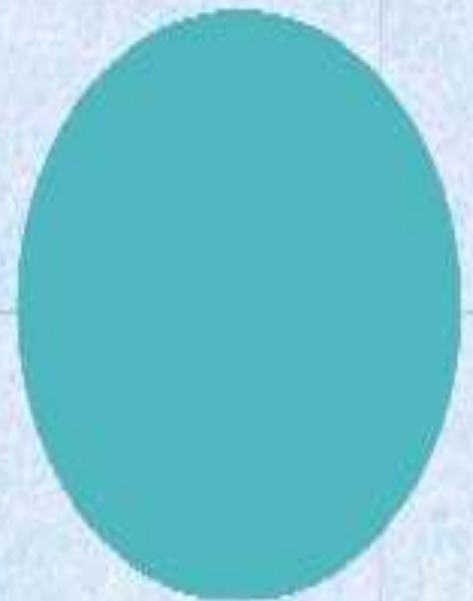

VEHICLE

- ✓ Also known as binder.
- ✓ Vehicle is an oil to which the base is mixed.
- ✓ Holds all constituents of paint.
- ✓ Helps spread it over the surface to be painted.
- ✓ Imparts durability, toughness & water proofness to paint film & resistance to weathering and gloss.
- ✓ E.g., :- linseed oil, nut oil, poppy oil & tung oil

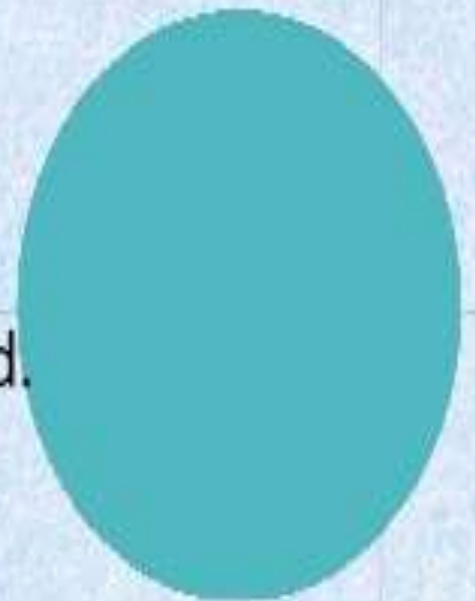

PIGMENTS

- ✓ Used to hide the surface imperfections.
- ✓ To impart the desired colour.
- ✓ Improves the impermeability & enhances resistance to weathering.
- ✓ Finely ground mineral, organic substances or metal powders.
- ✓ Affect the flow characteristics making it possible to paint vertical & uneven surfaces smoothly.

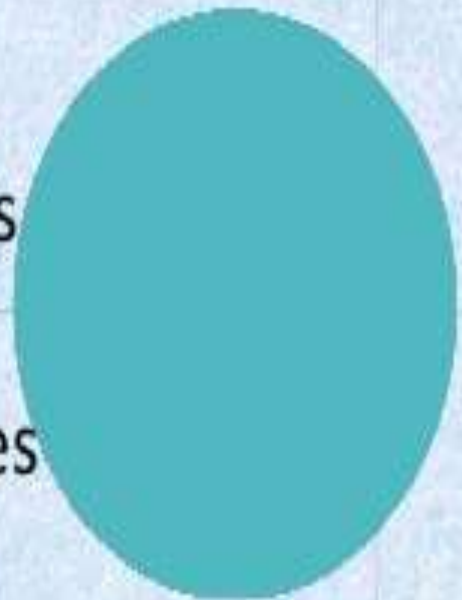

SOLVENTS

- ✓ Oils used to tin the paints, increase the spread.
- ✓ Also, known as thinners.
- ✓ They make paints of workable consistency & evaporate during drying of the film.
- ✓ It makes paint thinner and hence increases the coverage. It helps in spreading paint uniformly over the surface Turpentine and neptha are commonly used thinners. After paint applied, thinner evaporates and paint dries.
- ✓ Eg.,:- petroleum, spirit, naptha, turpentine oil.
- ✓ Most commonly used turpentine because of its high solvent power, excellent flattening properties.

DRIERS

- ✓ Also, known as plasticizers.
- ✓ Are chemicals added to paint for specific purposes.
- ✓ These are the compounds of metal like lead, manganese, cobalt.
- ✓ The function of a drier is to absorb oxygen from the air and supply it to the vehicle for hardening. The drier should not be added until the paint is about to be used.
- ✓ E.g., as catalyst for accelerating the drying of vehicle.
- ✓ Quantity of drier is limited to 8%.
- ✓ Excess affects the elasticity of paint leading to flaking failure.
- ✓ Red lead is the best for primary coat over steel & metal work.
- ✓ It produces extremely hard & tough film, almost impervious to air & moisture.
- ✓ The cost of zinc & lead chromates is high.
- ✓ E.g.,:- lecharge, lead acetate, red lead, manganese dioxide, cobalt, zinc.

ADULTERANTS

- ✓ These bring down the overall cost, reduce the weight and increase the durability.
- ✓ Adulterants also help to reduce cracking of dry paint and sometimes help to keep the pigment in suspension.
- ✓ Barium sulphate, calcium carbonate, magnesium silicate and silica are but a few examples. The best adulterant is barium sulphate.
- ✓ Silica is used only in the undercoats so as to take the advantage of its roughness in development of bond with the next coat.

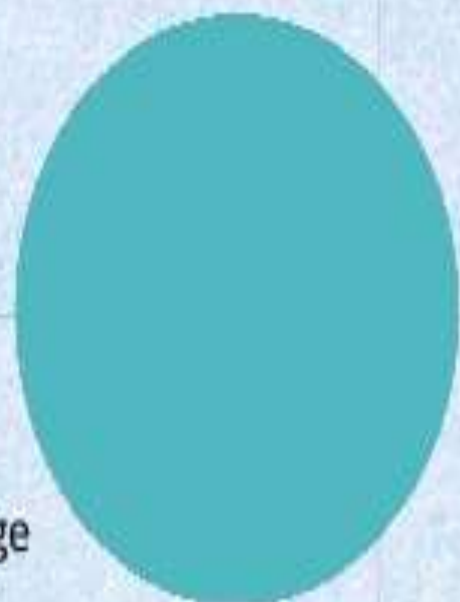

PROPERTIES OF AN IDEAL PAINT

- ✓ It should be possible to apply easily and freely.
- ✓ It should dry in reasonable time.
- ✓ It should form hard and durable surface.
- ✓ It should not be harmful to the health of workers.
- ✓ It should not be easily affected by atmosphere.
- ✓ It should possess attractive and pleasing appearance.
- ✓ It should form a thin film of uniform nature i.e., it should not crack.
- ✓ It should possess good spreading power.
- ✓ It should be cheap.

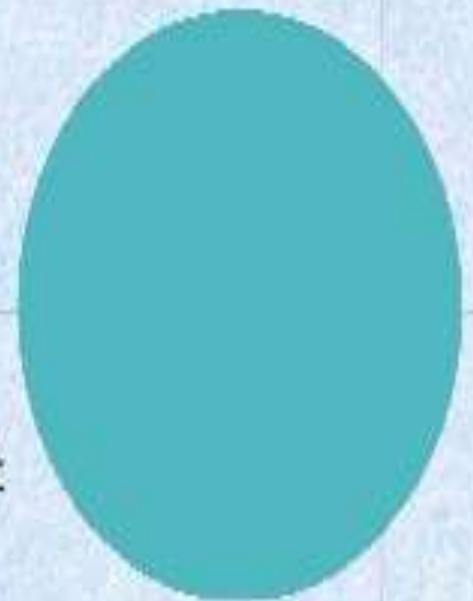

BUILDING CONSTRUCTION

SUBJECT CODE – 220734

BY – AMIT KUMAR

BUILDING CONSTRUCTION

Contents :

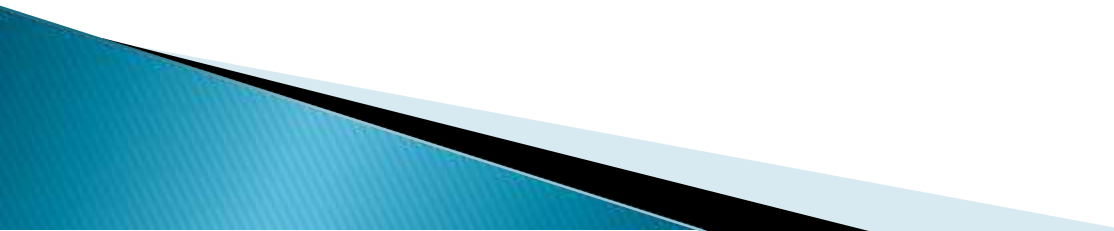
- Foundation & it's types
 - Stairs & it's classification
 - Masonry & it's types
 - Building & it's classification
 - Doors and windows & it's types
- 

Foundation

A **foundation** is a lower portion of **building** structure that transfers its gravity loads to the earth. **Foundations** are generally broken into two categories: shallow **foundations** and deep **foundations**. A tall **building** must have a strong **foundation** if it is to stand for a long time.

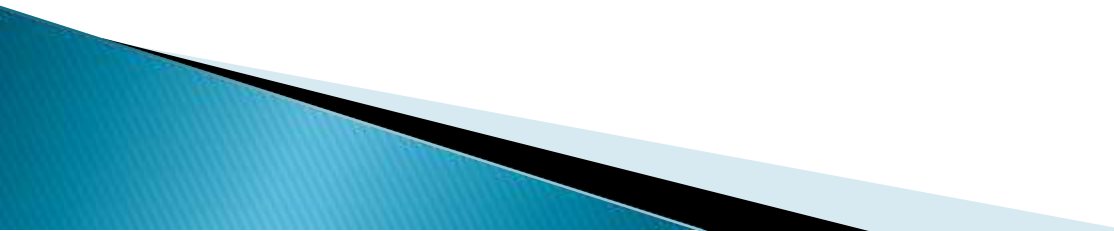

PURPOSE OF FOUNDATION

- The purpose of foundation is to transfer the load of the structure to the underlying soil without causing the danger of failure in shear and excessive settlement.
-

Factors Affecting Foundation Selection

- **Subsurface condition**
- **Type and magnitude of loading**
- **Type of structure**
- **Constraint – vibration, noise**
- **Cost**
- **Time**
- **Logistic**

Types Of Foundation

1. Shallow Foundation

It is further classified into:

- ❖ Wall footing
- ❖ Isolated footing
- ❖ Combined footing
- ❖ Raft footing
- ❖ Inverted arch footing
- ❖ Grillage footing

2. Deep Foundation

It is further classified into:

- Pile Foundation
- Well Foundation

Wall footing

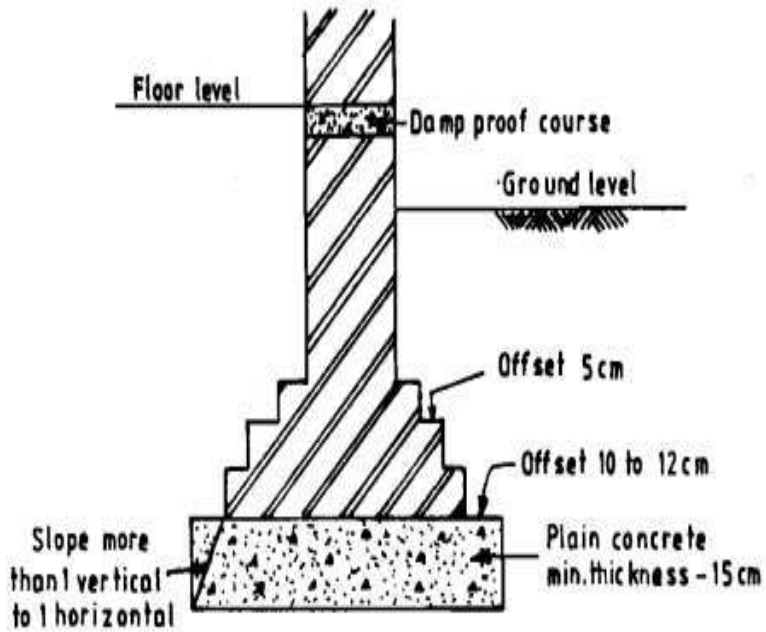

Isolated footing

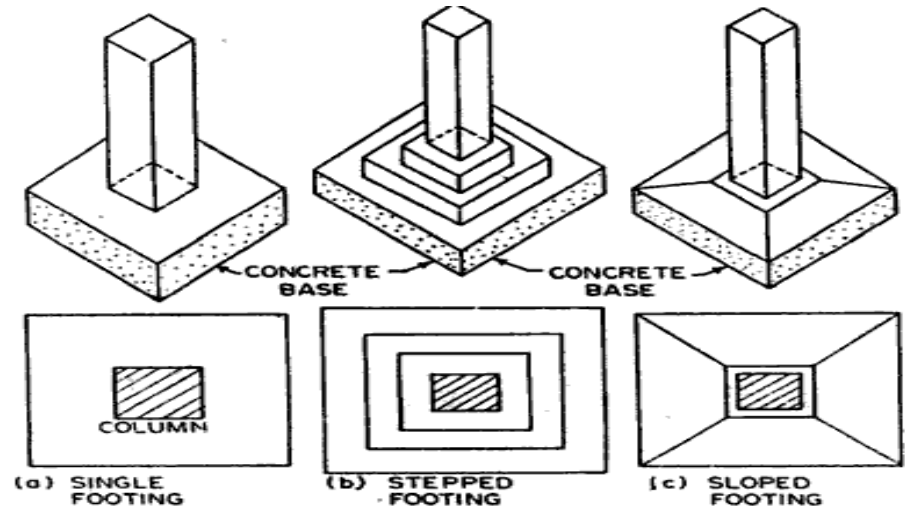

Grillage footing

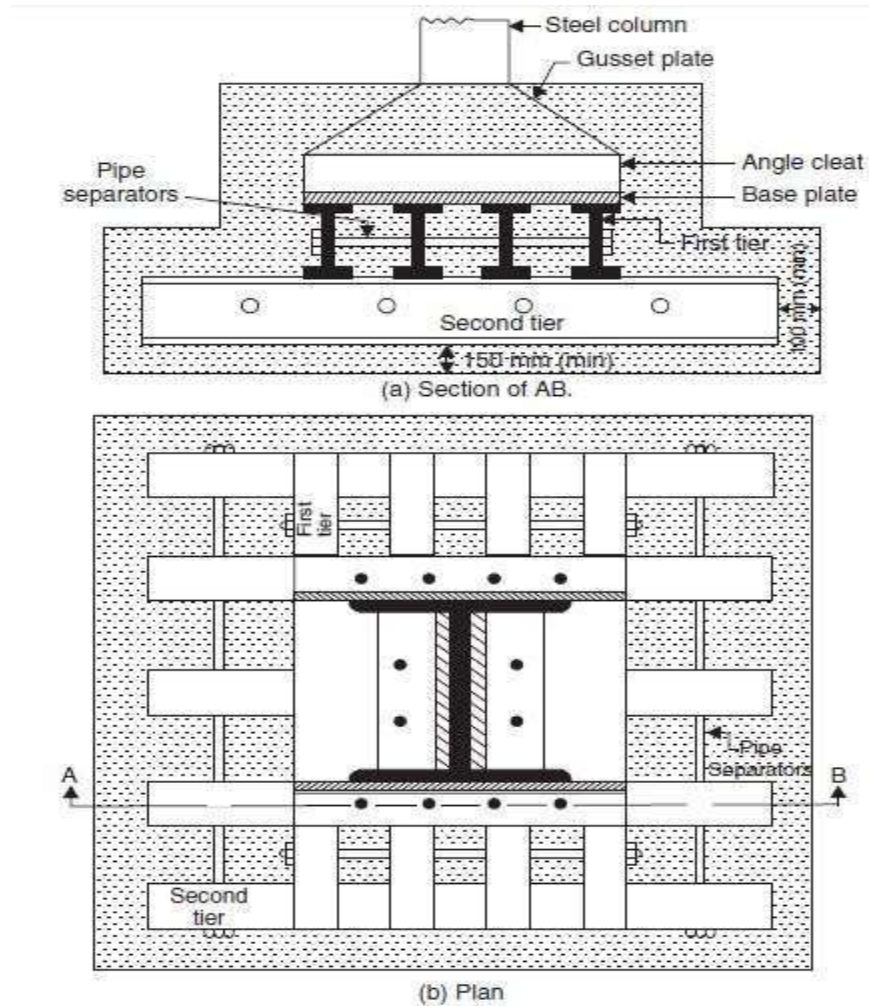
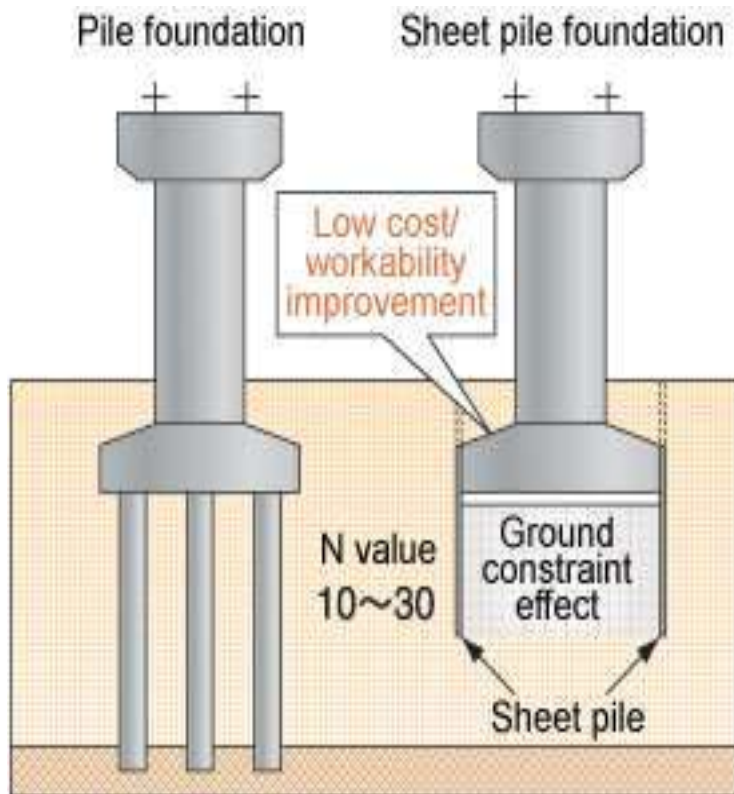

Fig. 7.7. Grillage foundation.

Types of Deep Foundation

Pile Foundation



Well Foundation

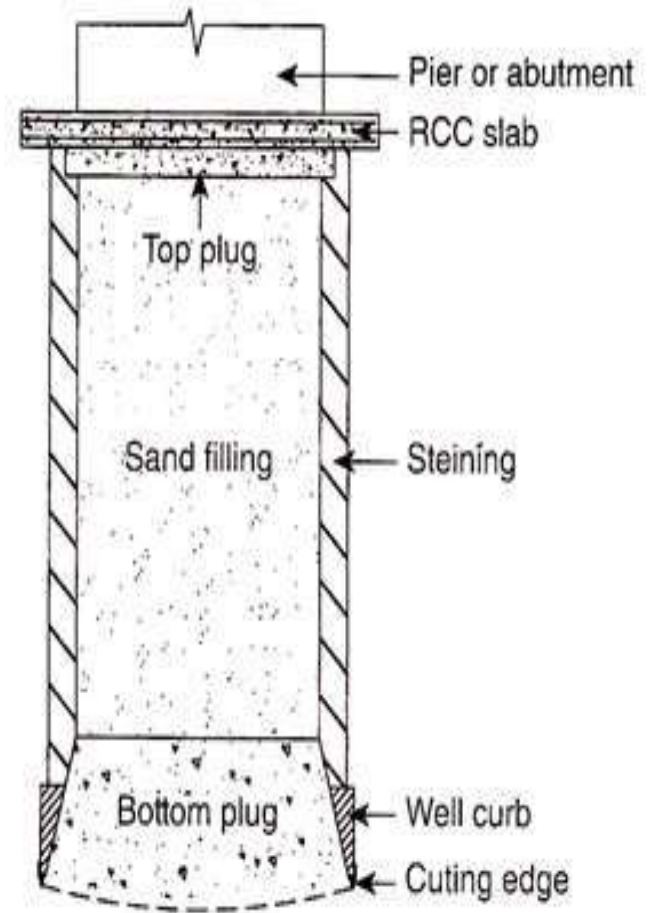

Figure 21.5 Components of a well foundation.

Stairs

A **stairway**, **staircase**, **stairwell**, **flight of stairs**, or simply **stairs** is a construction designed to bridge a large vertical distance by dividing it into smaller vertical distances, called **steps**. Stairs may be straight, round, or may consist of two or more straight pieces connected at angles.

Various Components or Parts of Staircase and their Details

Following are the various components of staircase:

Step

The step is composed of the tread and riser.

Tread The tread “depth” is measured from the outer edge of the step to the vertical “riser” between steps. The “width” is measured from one side to the other.

Riser

The vertical portion between each tread on the stair. This may be missing for an “open” stair effect.

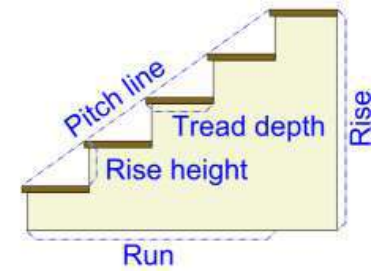

Landing – A landing is the area of a floor near the top or bottom step of a stair. An intermediate landing is a small platform that is built as part of the stair between main floor levels and is typically used to allow stairs to change directions, or to allow the user a rest.

Staircase – the entire structure relating to a stair, comprising steps, treads, risers, strings, balustrading, landings etc

FLIGHT

It is a series of steps without any platform or landing or break in their direction.

GOING

It is the horizontal distance between two successive riser faces.

NOSING

This is the outer projecting edge of a tread. This is generally made rounded to give more pleasing appearance and makes the staircase easy to navigate

WINDERS

They are tapering steps used for changing the direction of a stair.

SCOTIA

It is a moulding provided under the nosing to improve the elevation of the step, and to provide strength to nosing.

PITCH OR SLOPE

It is angle which the line of nosing of the stair makes with the horizontal.

STRINGS OR STRINGERS

These are the sloping members which support the steps in a stair. They run along the slope of the stair.

BALUSTER

It is a vertical member of wood or metal, supporting the hand rails.

HAND RAIL

It is a rounded or moulded member of wood or metal following generally the contour of the nosing line, and fixed on the top of balusters.

RUN

It is the total length of stair in a horizontal plane, including landings.

HEADER

It is the horizontal structural member supporting stair stringers or landings.

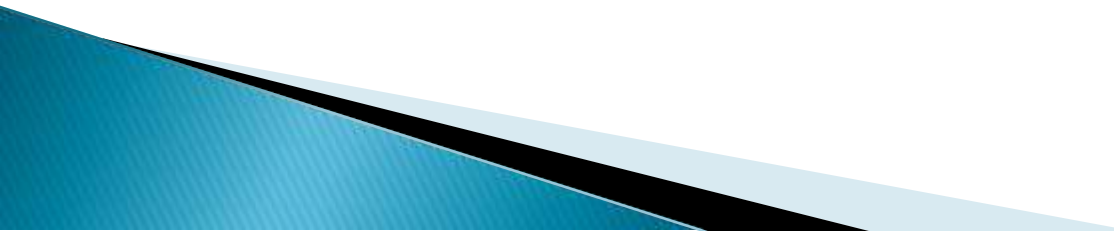

Requirement Of a Good Stair

1. LOCATION

It should preferably be located centrally, ensuring sufficient light and ventilation.

2. WIDTH OF STAIR

The width of stairs for public buildings should be 1.8 m and for residential buildings 0.9 m.

3. LENGTH

The flight of the stairs should be restricted to a maximum of 12 and minimum of 3 steps.

4. PITCH OF STAIR

The pitch of long stairs should be made flatter by introducing landing. The slope should not exceed 400 and should not be less than 250.

5. HEAD ROOM

The distance between the tread and soffit of the flight immediately above it, should not be less than 2.1 to 2.3 m. This much of height is maintained so that a tall person can use the stairs with some luggage on its head.

6. MATERIALS

Stairs should be constructed using fire resisting materials. Materials also should have sufficient strength to resist any impact.

7. BALUSTRADE

All open well stairs should be provided with balustrades, to avoid accidents. In case of wide stairs it should be provided with hand rails on both sides.

8. LANDING

The width of the landing should not be less than the width of the stair.

9. WINDERS

These should be avoided and if found necessary, may be provided at lower end of the flight.

10. STEP PROPORTIONS

The ratio of the going and the rise of a step should be well proportioned to ensure a comfortable access to the stair way.

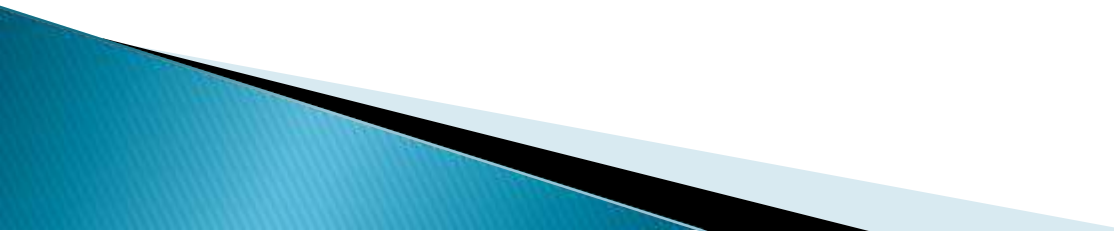

CLASSIFICATION OF STAIRS

1. STRAIGHT STAIR:

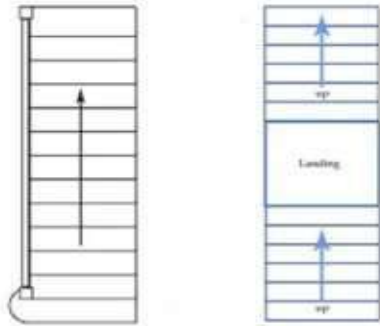

Straight Stair

2. DOGGED-LEGGED STAIR:

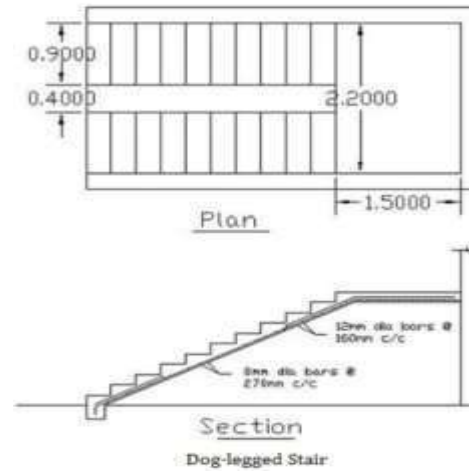

Dog-legged Stair

3. OPEN NEWEL STAIR:

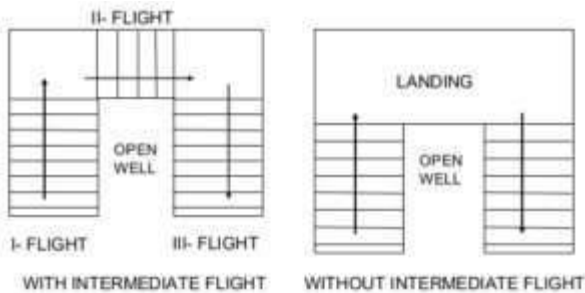

Open Newel Stairs

4. GEOMETRICAL STAIR:

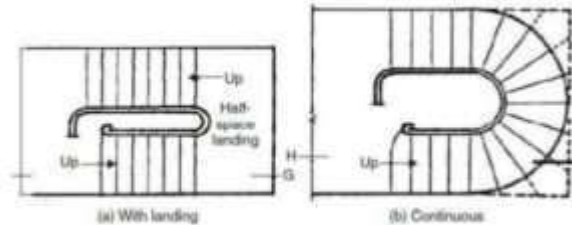

Geometrical Stair

5. CIRCULAR STAIR:



6. SPIRAL STAIR:

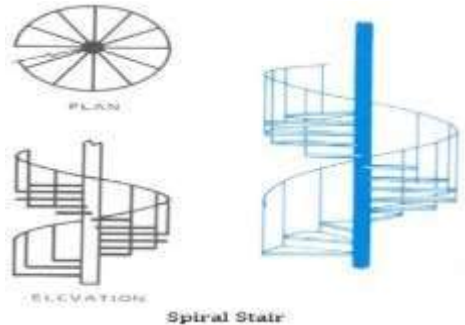

7. QUARTER-TURN STAIR:

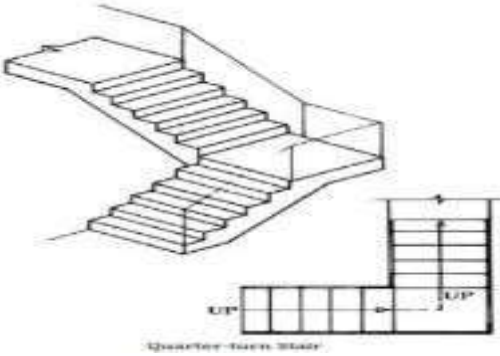

8. BIFURCATED STAIR:

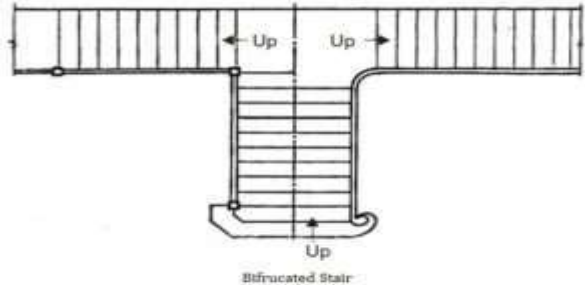

Masonry

Masonry consists of building structures by laying individual **masonry** units (brick, concrete block, stone, etc). Normally the **masonry** units are laid with cement mortar, which binds them together to create a structure. **Masonry** construction can provide beautiful walls and floors at economical prices.

Brick masonry

Brick masonry is used for construction of buildings and other structures by using brick stone, stone blocks, brick blocks with different types of masonry.

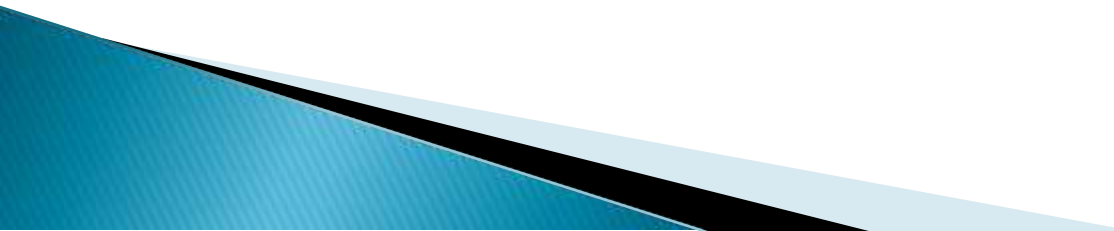

Application of the Brick Masonry

Brick masonry has a number of practical application and can be used very conveniently at places like construction of ordinary as well as important building ,foundation,walls,columns,ornamental works ,circular brick work buttresses, retaining structures, window sills, jambs, corbels, coping, fire places, flumes, tall chimney,cavity walls,floors,arches,culverts,steps,etc.

Advantages of Brick masonry

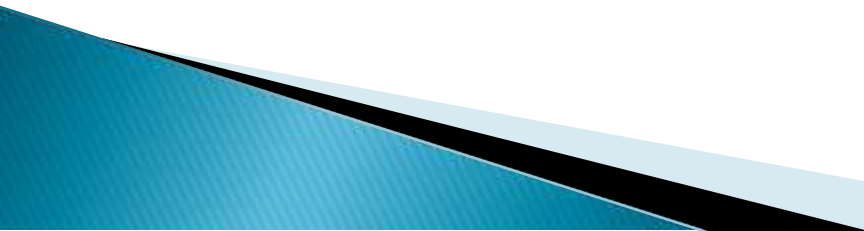
- Since shape and size of bricks are uniform, it do not need skilled labour for the construction.
 - Bricks are light in weight and hence handling them is easy.
 - Bricks are easily available around cities and their transportation cost is less because their weight is less.
 - It is possible to use all types of mortar in brick masonry.
 - Thinner walls can be constructed with bricks but it is not so with stones.
 - It is easy to form openings for doors and windows.
 - Dead load of brick masonry is less.
 - Brick masonry has better fire and weather resistance compared to stone masonry.
- 

TECHNICAL TERMS USED IN MASONRY WORKS

1. HEADER:

It is a full brick or stone which is laid with its length perpendicular to the face of the wall.

2. STRETCHER:

It is a full brick or stone in which is laid its length parallel to the face of the wall.

3. BOND:

It is a term applied to the overlapping of bricks or stones in a wall in alternate courses, to bind the whole wall together.

4. COURSE:

A horizontal layer of bricks or stones is termed as course.

5. HEADER COURSE:

It is a course of brickwork entirely composed of headers.

6. STRETCHER COURSE:

It is a course of brickwork in which all the bricks are laid as stretchers.

7. BED:

It is a term used to indicate the lower surface of bricks or stones in each course. It may also be termed as surface of the bricks on which it rests.

8. FACE:

The surface of a wall exposed to weather is termed as face.

9. FACING:

The material used in the face of the wall is known as facing.

10. BACK:

The inner surface of the wall which is not exposed to the weather is termed as back.

11. BACKING:

The material used in forming the back of the wall is known as backing.

12. HEARTING:

The portion of a wall between facing and backing is termed as hearting.

13. JOINT:

The junction of two or more bricks or stones is called joint.

14. RACKING BACK:

The process of stopping the unfinished end of a wall in stepped fashion.

15. BAT:

It is a portion of a brick cut across the width or a brick cut by some fraction of its length.

16. CLOSER:

It is a portion of a brick cut in such a manner that its one long face remains uncut.

17. KING CLOSER:

It is a brick which is cut in such a way that the width of one of its end is half that of a full brick.

18. QUEEN CLOSER:

It is a term applied to a brick which is half as wide as full brick. Queen closer is made by cutting a brick lengthwise into two portions.

19. BEVELLED CLOSER:

It is similar to king closer with the only difference that the whole length of the brick is bevelled for maintaining half width at one end and full width at the other.

20. MITRED CLOSER:

It is a brick whose one end is cut splayed or mitred for the full width.

21. PERPEND:

It is a vertical joint on the face of a wall directly over vertical joints in an alternate course.

22. FROG:

It is a depression on the top face of a brick. Frog provides a recess for the mortar which on setting forms a key and prevents the displacement of the brick above.

23. PLINTH:

The horizontal projecting or flush course of stone or brick provided at the base of the wall above ground level is known as plinth.

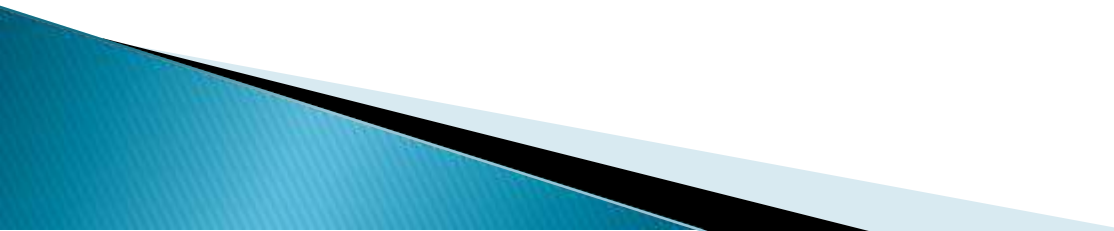

24. SILL:

It is a horizontal member of brick, stone, concrete or wood provided to give support for the vertical members of a window.

25. JAMBS:

The vertical sides of a finished opening for door, window or fire place etc. are termed as jambs.

26. REVEALS:

Reveals are the exposed vertical surfaces left on the sides of an opening after the door or window frame has been fitted in position.

27. LINTEL:

A horizontal member of stone, brick, steel or RCC, used to support the masonry or load above an opening.

28. ARCH:

A mechanical arrangement of wedge-shaped blocks of stone or brick arranged in the form of a curve supporting the masonry or load above an opening.

29. CORNICE:

It is a horizontal moulded projection provided near the top of a building or at the junction of a wall and ceiling.

30. PARAPET:

It is a term applied to a low wall built around a flat roof to act as a protective solid balustrade for the users of the terrace.

31. WEATHERING:

Weathering is the term applied to the bevelled top surface of a stone.

32. GABLE:

It is a triangular shaped portion of masonry at the end of a sloped roof.

33. SPALLS:

Chips or small pieces of stone broken off a large block are termed as spalls.

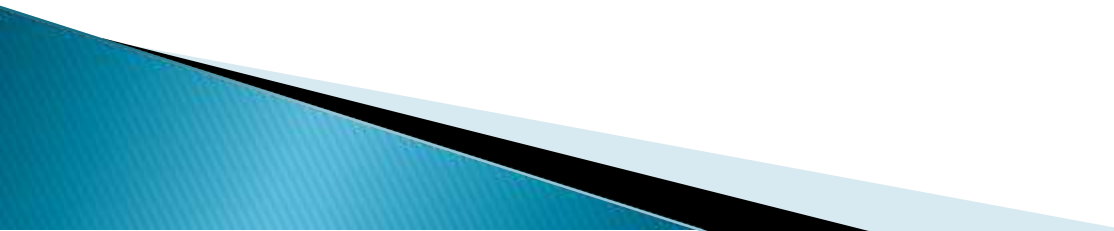

34. COLUMNS:

It is an isolated vertical load bearing member whose width does not exceed four times its thickness.

35. PIER:

It is a vertical member of stone or brick masonry constructed to support an arch, beam or lintel etc.

36. BUTTRESS:

It is similar to pier built on the exterior of a wall properly bonded to it.

37. CORBEL:

It is the extension of one or more course of brick or stone from the face of a wall.

38. THRESHOLDS:

The arrangement of steps provided from ground level to reach plinth level on external doors and verandah is termed as thresholds.

Types of Bonds in Brick Masonry Wall Construction :

The most commonly used types of bonds in brick masonry are:

- | | |
|-------------------|----------------------|
| 1. Stretcher bond | 6.English cross bond |
| 2. Header bond | 7.Brick on edge bond |
| 3. English bond | 8.Raking bond |
| 4. Flemish bond | 9.Facing bond |
| 5. Dutch bond | 10.Garden wall bond |

1. Stretcher bond

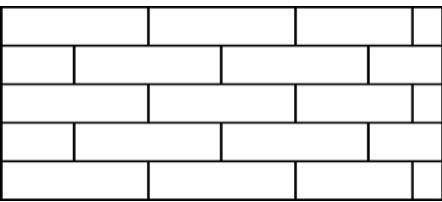

2. Header bond

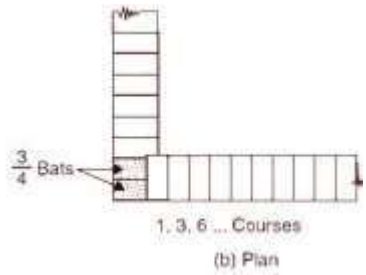
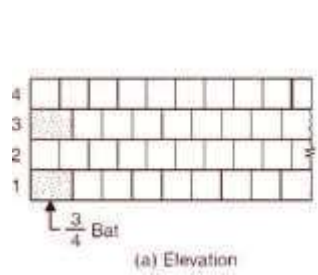

3. English bond

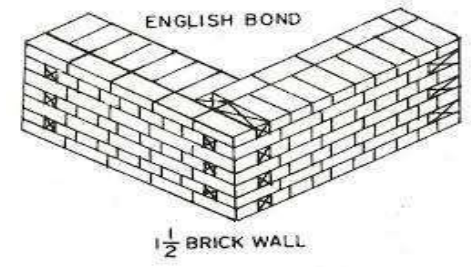

4. Flemish bond

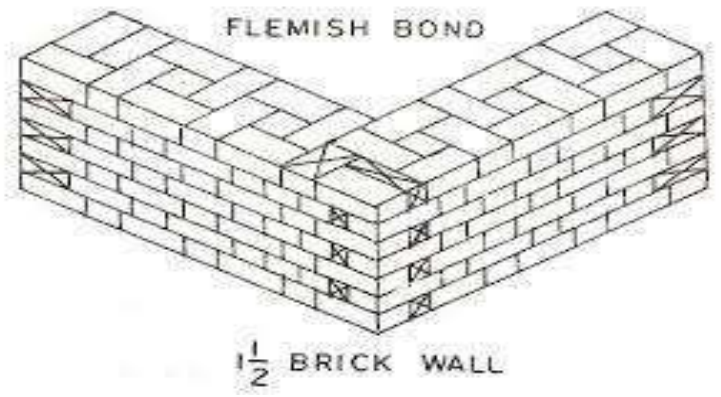

5. Dutch bond

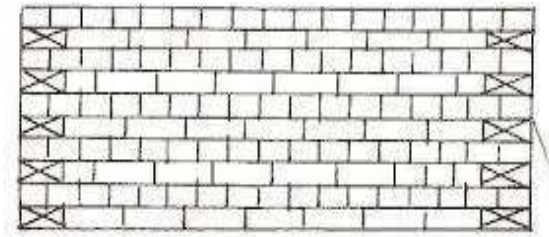

Elevation of a wall in Dutch bond

6.English cross bond



Elevation of wall in English cross-bond.

7.Brick on edge bond

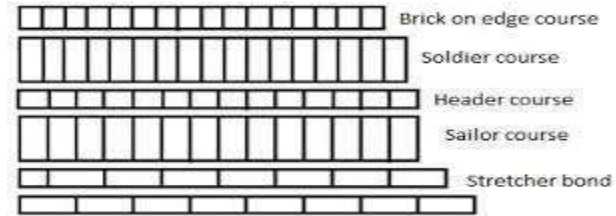

8.Raking bond

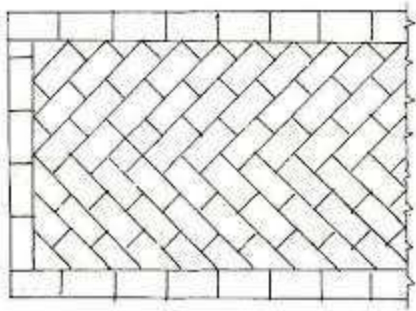

Plan showing arrangement of bricks in Herring-bone bond.

10.Garden wall bond

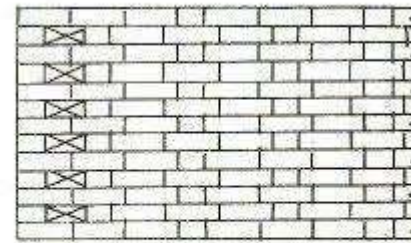

Elevation of wall in Flemish garden wall bond

Stone masonry

The art of building the structures using stone blocks and mortar is termed as stone masonry. It is preferred where building stones are abundantly available in nature. These stones when cut and dressed to proper shape and size provide an economical material for the construction of various parts of the building in hilly terrains.

Glossary of terms

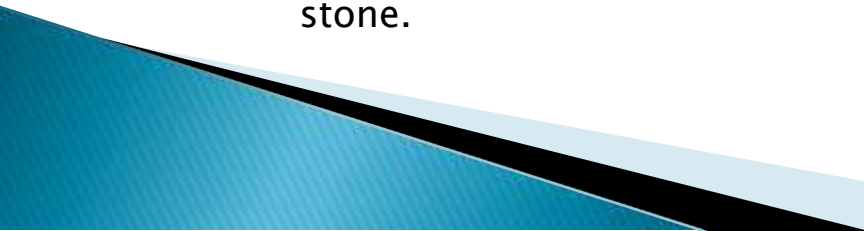
1. **Natural Bed:** The setting of the stone on the same plane as it was formed in the ground. This generally applies to all stratified materials.
 2. **Bed:** The top or bottom of a joint; natural bed-surface of stone parallel to its stratification.
 3. **Bedding plane.** The plane along which a stone can be separated, easily, is called bedding plane. Stones are laid in a structure so that load acts perpendicular to their bedding plane.
 4. **Cornice.** The course of a masonry provided at ceiling level of the roof projecting outside the surface of the wall of a building, is called cornice.
 5. **Throating.** A small groove cut on the underside of a projecting chajja, cornice, coping, to discharge rain water without trickling to walls, is called throating.
 6. **Coping:** A flat stone used as a cap on walls or around the perimeter of patios and pool decks.
 7. **Template:** A detailed pattern or drawing showing exact dimensions to be fabricated.
 8. **Bond stones:** Bond stones are generally cut to twice the bed thickness of the material being used.
 9. **Reveals.** The exposed vertical surfaces perpendicular to window or door frame, are called reveals.
 10. **Drip stone.** A projecting dressed stone having its undersurface throated, is called drip stone.
- 



Classification of Buildings

Contents:

- * Building structure.
- * Non building structure.
- * classification of buildings;
 - > Based on occupancy.
 - > Based on type of construction.



Building structure:

- A **building** structure is a man-made structure with a roof and walls standing more or less permanently in one place, such as a house or factory.
- Buildings are classified into two categories.
 - 1) Based on the occupancy.
 - 2) Based on the type of construction.



❖ Buildings classified, based on the occupancy:

Every building or portion of land shall be classified according to its use or the character of its occupancy as a building of Occupancy. They are categorized into the following types.

- 1) Agricultural buildings
- 2) Commercial buildings
- 3) Residential buildings
- 4) Educational buildings
- 5) Government buildings
- 6) Industrial buildings
- 7) Military buildings
- 8) Religious buildings
- 9) Transport buildings
- 10) Power plants



Educational buildings:

- This occupancy type shall include any building or portion thereof in which education, training and care are provided to children or adults. This occupancy shall be subdivided as follows :



Museum



School



Archive



library

Government buildings:

➤ It is a building that houses a branch of government.



Capitol



Embassy



Prison



Fire station



Post office

Agricultural buildings:

- ✓ They are the structures designed for farmers and for agricultural practices, for growing and harvesting crops, and to raise live stock.



barn



Chicken coop



Farm house

Residential buildings:

- ✓ A **Residential** building is that, in which housing predominates, as opposed to industrial and commercial areas. building may vary significantly between, single-family building, multi-family **building**, or mobile homes.



Apartment



Villa



Bungalow



Nursing home

Commercial buildings:

- They are the buildings, which are used exclusively for commercial use.



Ware house



Bank



Convention centers



Gas stations



Automobile companies

Transport buildings:

- This is a structural building which consists of the means of equipment necessary for the movement of passengers or goods on land, water, and air ways.



Air port



Railway station



Parking garage



Light house



Bus station

Power stations/power plants:

- These buildings serve as the industrial facility to generate electric power.



Geo thermal
power plant



Fossil fuel power
plant



Nuclear power
plant



Renewable energy power station

DOORS & WINDOWS

DOOR

A **door** is a moveable barrier secured in a wall opening.

Functions:

1. They admit ventilation and light.
2. Controls the physical atmosphere within a space by enclosing it, excluding air drafts, so that interiors may be more effectively heated or cooled.
3. They act as a barrier to noise.
4. Used to screen areas of a building for aesthetic purposes, keeping formal and utility areas separate.

Components of a door:

- a) Door frame
- b) Door shutter

Door frame

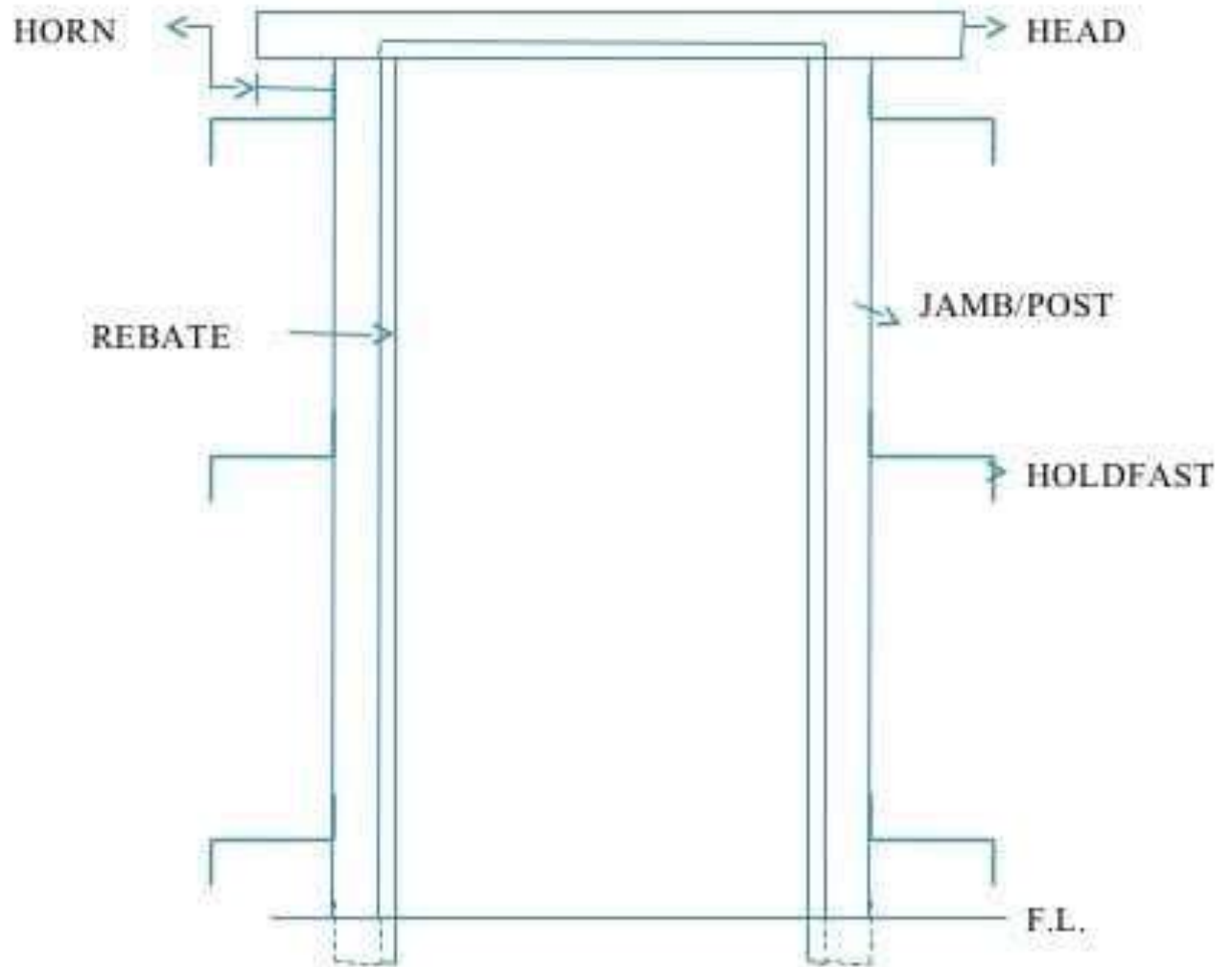

Location of door in a building

- The number should be kept as minimum.
- It should meet the functional requirement.
- It should preferably be located at the corner of the room, nearly 20 cm from corner.
- If in a room, more than 2 doors are there, they shall be located facing each other.

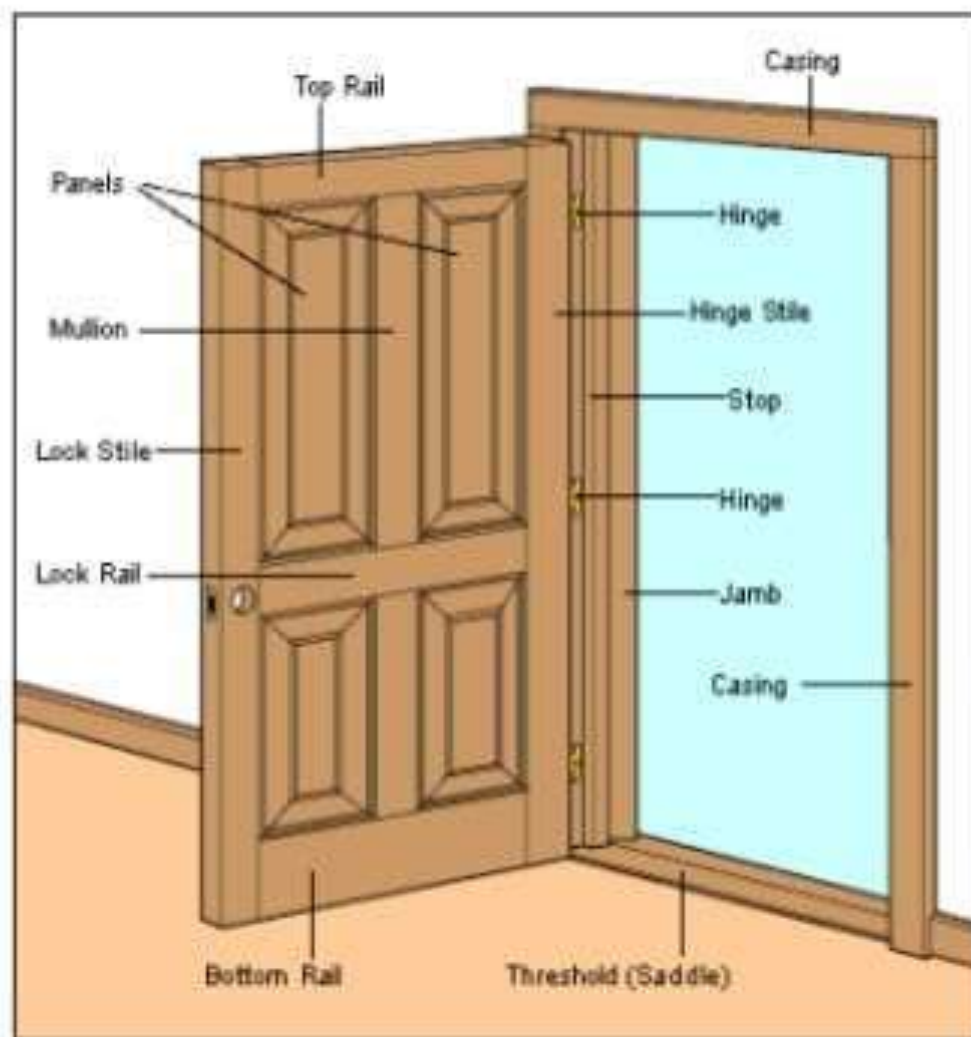



Sliding Window or Slider:

- Has two or more sashes that overlap slightly but slide horizontally within the frame.
- Suitable openings or grooves are left in the frame or wall to accommodate the shutters when the shutters are opened.

Types of Doors

On the basis of working operations

- Hinged doors
 - Battened type
 - Framed and paneled
 - Glazed/Sash
 - Flushed
 - Louvered
 - Wire-guage
- Revolving doors
- Sliding doors
- Swing doors
- Collapsible doors
- Rolling shutter

DOOR FRAMES

Materials used for door frames

- Timber
- Steel
- Aluminium
- Concrete
- Stone

SIZES OF DOORS

The common width-height relations used:

- Width = 0.4 – 0.6 Height
- Height = (width + 1.2)m

General sizes used:

a) Residential

External door – 1.0 x 2.0 to 1.1 x 2.0 m

Internal door - 0.9 x 2.0 to 1.0 x 2.0 m

Bath & WC – 0.7 X 2.0 to 0.8 x 2.0 m

Garages for cars – 2.25 x 2.25 m to 2.40 x 2.25 m

b) Public

1.2 x 2.0 m **or** 1.2 x 2.1 m **or** 1.2 x 2.25 m



WINDOWS

Window details

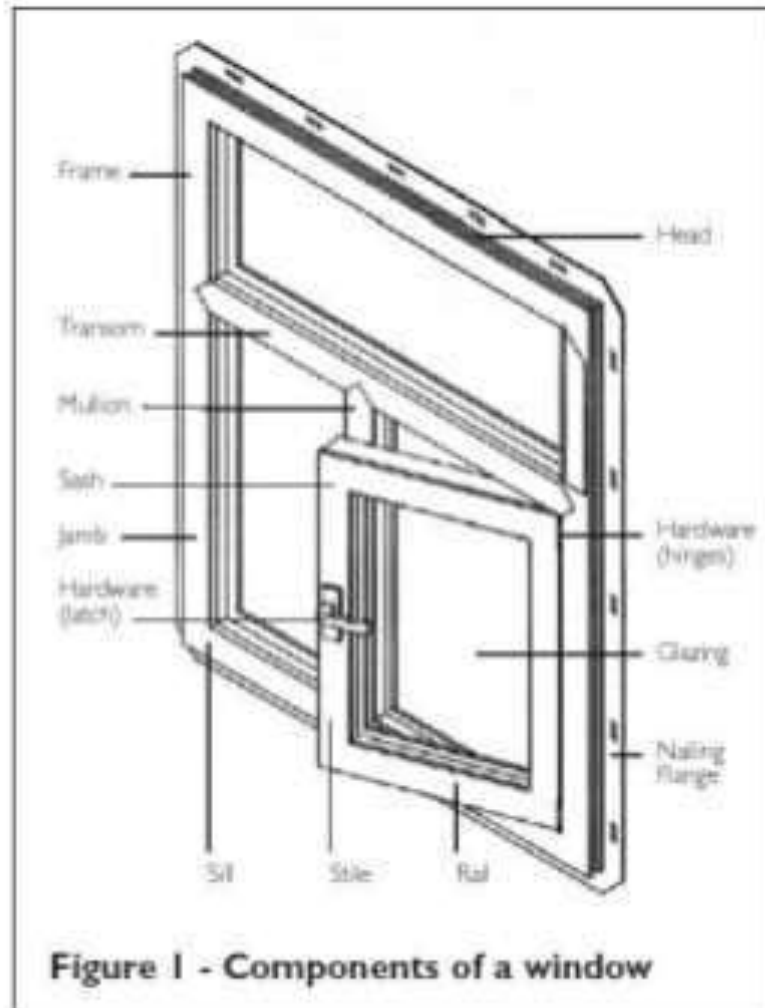

TYPES OF WINDOWS

Fixed windows

- In this type, the glass pane is permanently fixed in the opening of the wall.
- The shutter can't be opened or closed.
- The function is limited to allowing light and or permit vision in the room.
- No rebates are provided to the frame.
- The shutters are fully glazed.
- In homes they are generally decorative windows near doors, stairwells and high-places or are used in combination with other styles.

- **Glazed window**

This is a type of casement window where panels are fully glazed.

The frame has styles, top rail and a bottom rail.

The space between top and bottom rail is divided into number of panels with small timber members called, sash bars or glazing bars.

The glass panels are cut 1.5-3.0 mm smaller in size than the panel size to permit movement of sash bars.

Glass panes are fixed to sash bars by putty or by timber beads.

Double-hung windows

- It has two panes, top and bottom that slide up and down in tracks called stiles.
- The most common used windows today. When open, these windows allow air flow through half of its size.
- The two parts are not necessarily the same size.
- Traditionally, each shutter is provided with a pair of counterweights connected by cord or chain over pulleys.
- When the weights are pulled, the shutters open to required level.
- It is possible to have controlled ventilation.
- Sash windows may be fitted with simplex hinges which allow the window to be locked into hinges on one side, while the rope on the other side is detached, allowing the window to be opened for escape or cleaning.
- Nowadays, most new double-hung sash windows use spring balances to support the sashes.

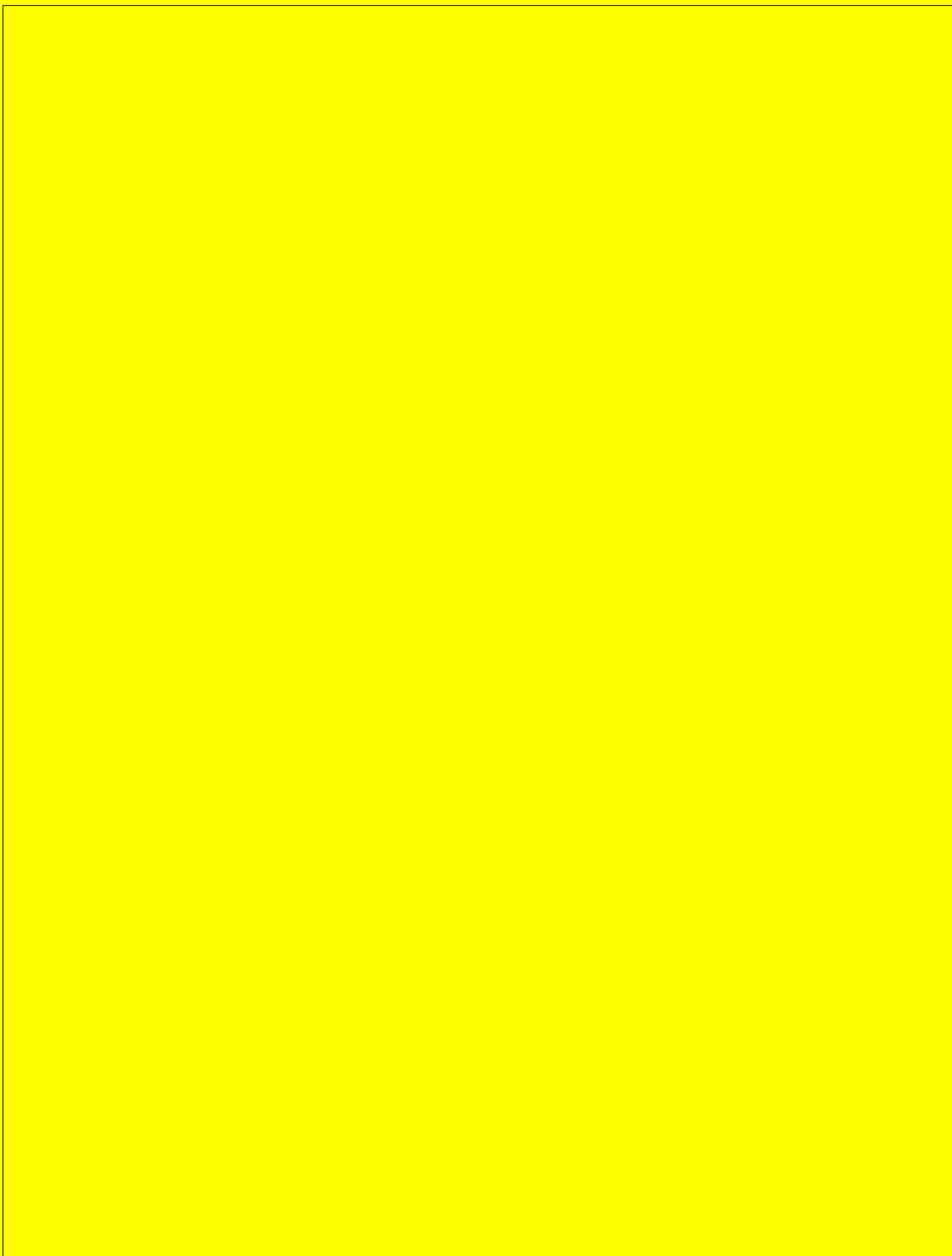

Introduction

- A building or construction project requires a complete set of specialised drawings. These drawings, called a project set, are used by the local planning department and building control, as well as by builders, joiners, plumbers, electricians and water, gas and telephone engineers.
- The buildings are designed by an architect with a team of technicians and surveyors to help plan and produce the drawings. The types of drawings are designed by an architect with a team of technicians and surveyors to help plan and produce the drawing.

Introduction

- The types of drawings you need to know about are:
 - location plans
 - site (block) plans
 - floor plan

- Drawings for new buildings require approval from the building control department and the planning department before construction work can begin. The building control department checks that the quality of design and construction meet British standards. The planning department assesses whether or not the style and proportions of the proposed building are appropriate for the location.

Types of Drawings:

- Engineering drawings
- Architectural drawings
- Technical drawings
- As built drawings
- Shop drawings

1. Engineering drawing:

- **Definition** :A schematic representation of a *building*, *object*, or *component* made according to defined conventions and projected to serve in the construction or fabrication of the thing depicted.
- Engineering drawings are frequently used to describe public works projects, such as :
 - *bridges, highways, and dams.*

2. Architectural drawing

- **Definition** A sketch, diagram, plan, or schematic used to design, construct, and document buildings and other structures.
- The drawings may be used to indicate the overall appearance, inside or outside the structure, or they may be used to indicate precise measurements and other details for construction. Drawings, especially those for construction purposes, may be issued as a set, with different sheets indicating different types of construction (electrical, mechanical, plumbing).

□ As-built drawing

- **Definition** Architectural drawings that reflect changes made during the construction process, recording differences between the original design and the completed structure.
- As-built drawings are based on design drawings used during construction, where measured drawings are usually made long after construction is completed and no design drawings exist

□ Technical drawing:

- **Definition** A graphic using lines and symbols that follows specific conventions of scale and projection, typically used in architecture, construction, engineering, or mapping

□ A shop drawing:

- **Definition** It is a drawing or set of drawings produced by the contractor, supplier, manufacturer, subcontractor, or fabricator.
- Shop drawings are typically required for pre-fabricated components. Examples of these include: elevators, structural steel, trusses, pre-cast, windows, appliances, cabinets, air handling units and millwork.
- **Shop drawings** are not produced by architects and engineers under their contract with the owner. The shop drawing is the manufacturer's or the contractor's drawn version of information shown in the construction documents. The shop drawing normally shows more detail than the construction documents. It is drawn to explain the fabrication of the items to the manufacturer's production crew. The style of the shop drawing is usually very different from that of the architect's drawing.

□ Architectural Drawings used for:

- 1. Building elements seen in true size, shape, orientation . "scale"
- 2. Describe form & construction of building component.
- 3. It is the base drawings for other construction work like, electrical, plumbing, mechanical..."

□ Site plan

Preparing the architectural drawings:

■ Plans

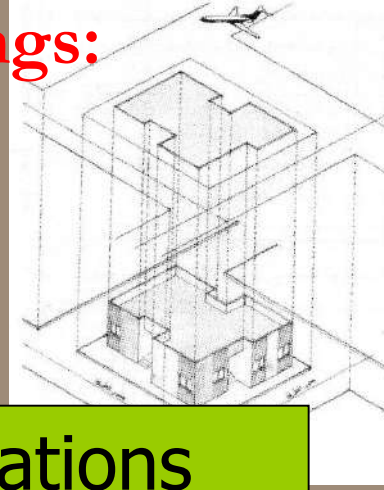
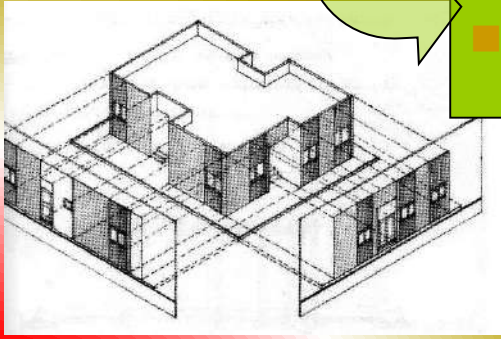

■ Elevations

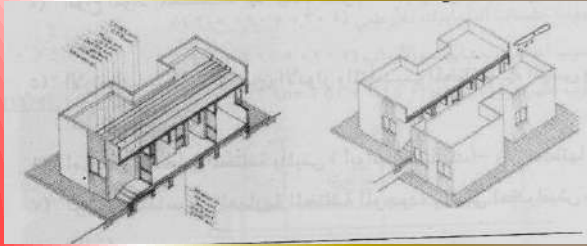

■ Sections

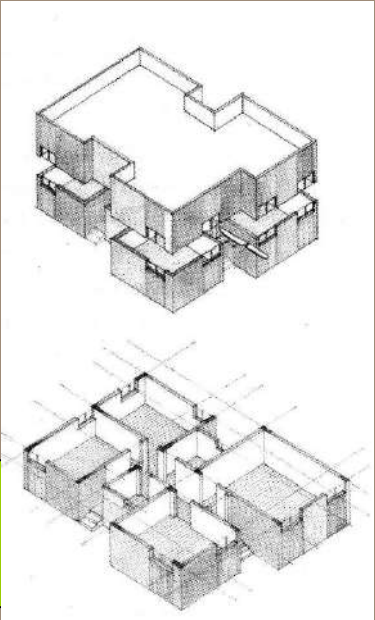

- **The site plan:** is a view looking down at a building from above, illustrating its location & orientation on a plot land & providing information about the site's topography, landscaping utilities ,and site work.
- **The importance of site plan:**
 - It illustrates the existing natural & built features.
- **The building section:** is a vertical pane cut through a building.
Or: it is a drawing of interior & exterior partitions and roofs and ground floor in addition of interior elevations seen beyond the plane of cut.
- **The importance of The building section:**
 1. Illustrate building construction.
 2. Technical implementation (precast- prestress...).
 3. Types of slab (roof plate) solid slab, hollow block, flat slab...).
 4. Building material (block, stone, concrete,...).
 5. Height of the building and levels.
 6. Details and finishing.
 7. Measurements.

- **The floor plan**: is a view looking down/ a horizontal plane is cut through a building from above about 1.5m, illustrating it's the horizontal dimensions of a building spaces, the thickness & construction of vertical walls & columns that define these spaces.
- **The importance of plans**:
 1. Define the spaces & its functional relationship.
 2. Illustrates places of openings (doors- windows).
 3. Finishing.
 4. Entrance (main- secondary)
 5. Utilities (stairs- elevators- mechanical room- baths- stores....)
 6. Structural system:
 1. R.C, steel, bearing walls...
 2. Columns, beams,...
 3. Thickness of walls (exterior & interior)
 7. Measurement and cost (quantity survey)

- **Building elevations**: is views of a building's exterior perpendicular to the principle vertical surfaces.
- **The importance of The building section:**
 1. Finishing
 2. Openings
 3. Size, shape , materials of exterior surfaces
 4. Size proportion
 5. Heights of the building
 6. Measurements

Location Plan

- It identifies the location of the proposed new building within its surroundings. It also helps the builder to plan the layout of a new building scheme and is required by the local government planning department which decided whether or not to approve the project.
- Neighbouring buildings and their boundaries are shown, as are roads, street names and fields.
- The **scale** of the drawing depends on the size of the whole building scheme but is normally **1:1250**
- All building projects come under local authority control

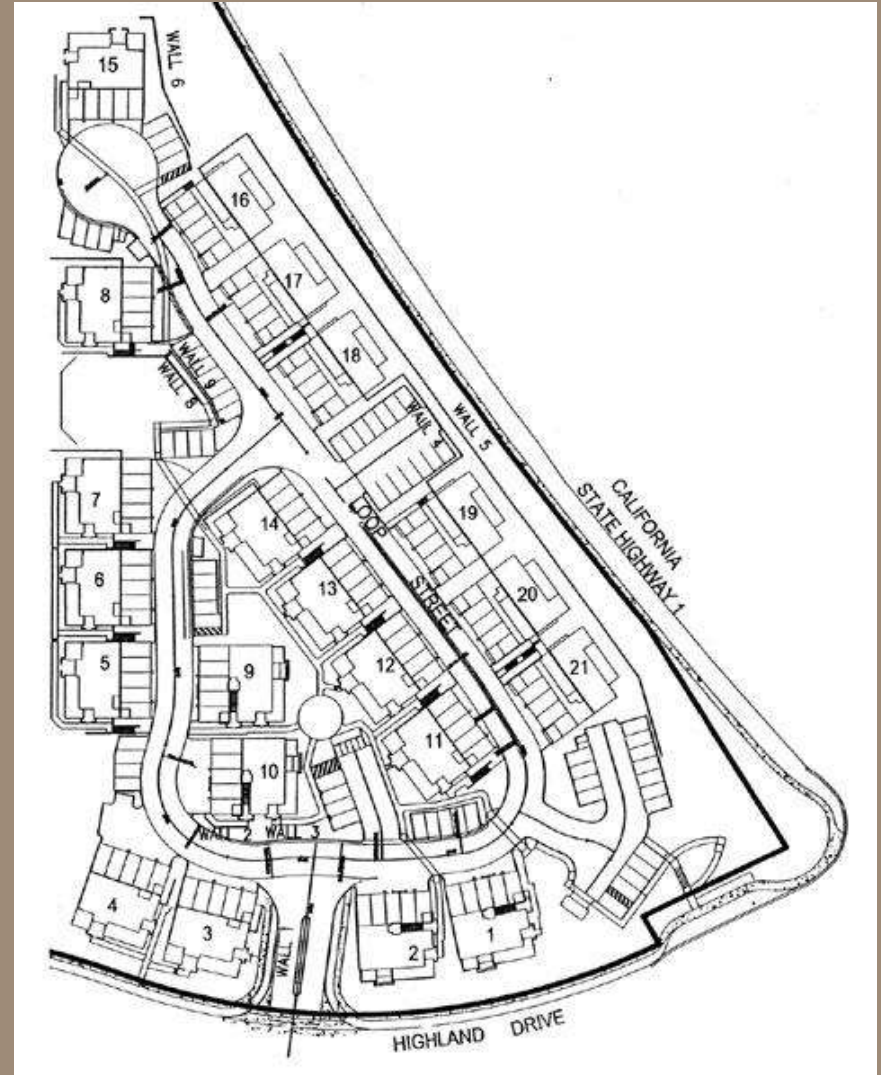

Floor Plan

- A floor plan is a type of sectional view of the building with the roof and a few layers of bricks removed to show:
 - the arrangement of rooms
 - the positions of windows and doors
 - the types of internal and external

Floor plans are used by builders, plumbers, electricians and joiners to help plan the construction work and to cost the building materials.

The scale of a floor plan depends on the size of the building but for most domestic buildings a scale of **1:50** is used

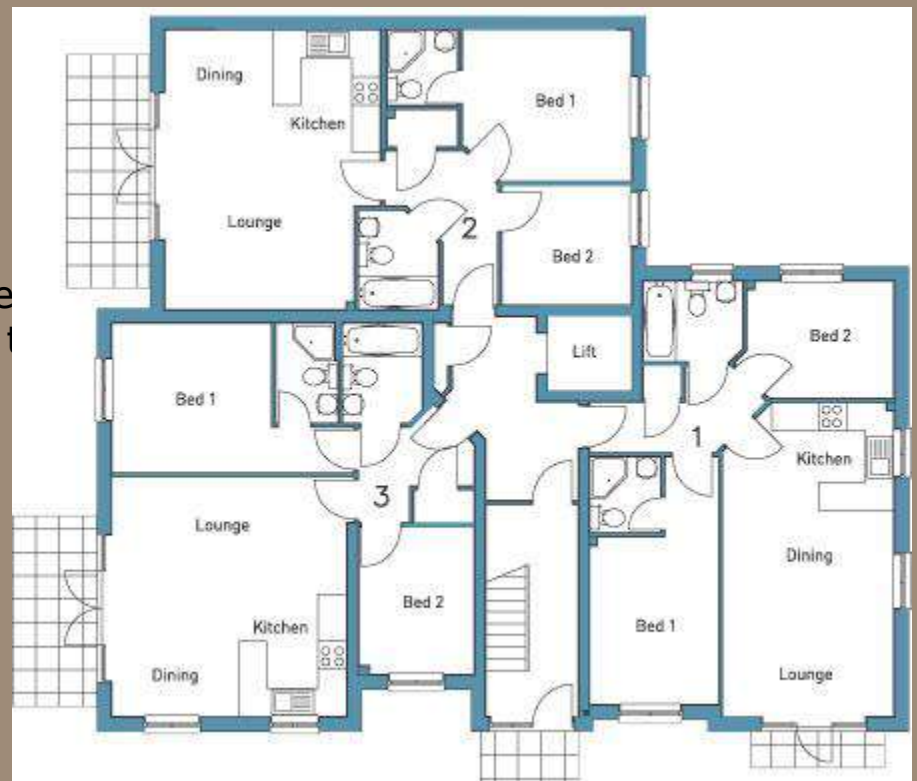

- Floor plan can also include:
- the dimensions of each room & the exact positions of doors & windows
 - the layout of water pipes (plumbing)
 - the layout of electrical cabling and positions of sockets, switches and fuse boxes

Architectural Plans

- ❑ An Architect is a person who designs houses, buildings, and other structures.
- ❑ Architects make plans when they are designing a new structure. These plans are usually sketches, drawings or miniature models of the structure they are going to build.

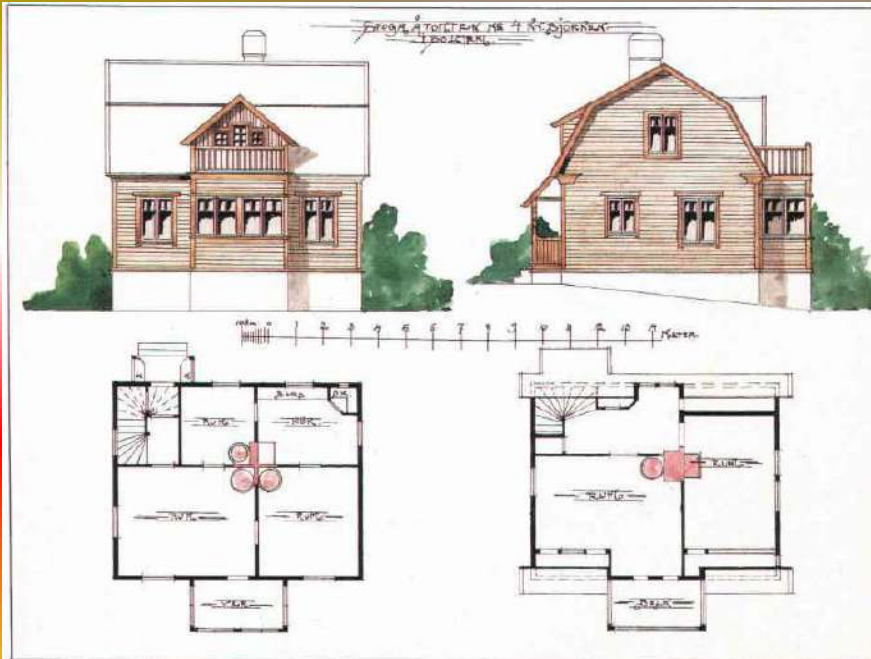

Architectural Plans – Drawing Plans for a House

- When an architect is making plans for a house, they draw several different types of plans. Each plan is a different point of view of the building.

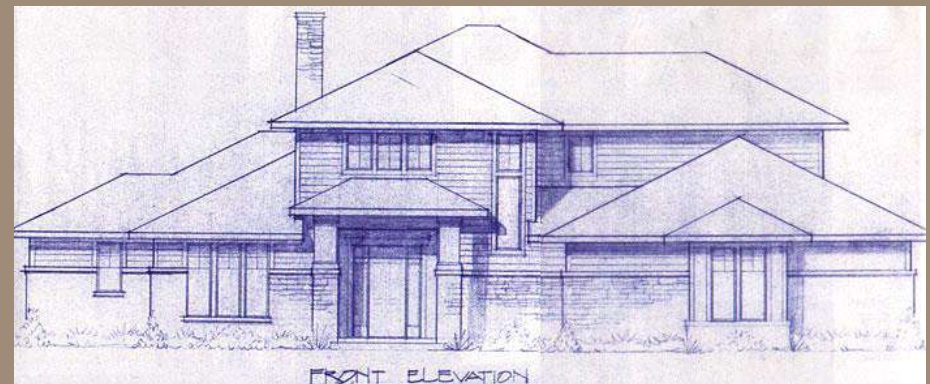
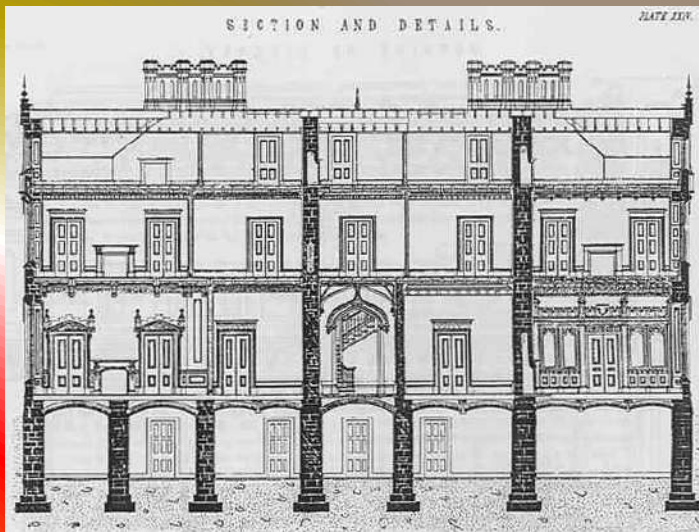
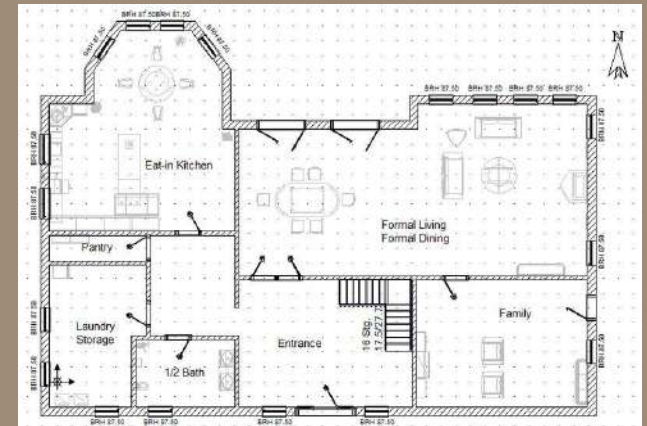

Architectural Plans – Front Elevation



Architectural Plans – Section Drawing



Section Drawing

View from the front where you can see through the walls into the house or building.

Architectural Plans – Floor Plan

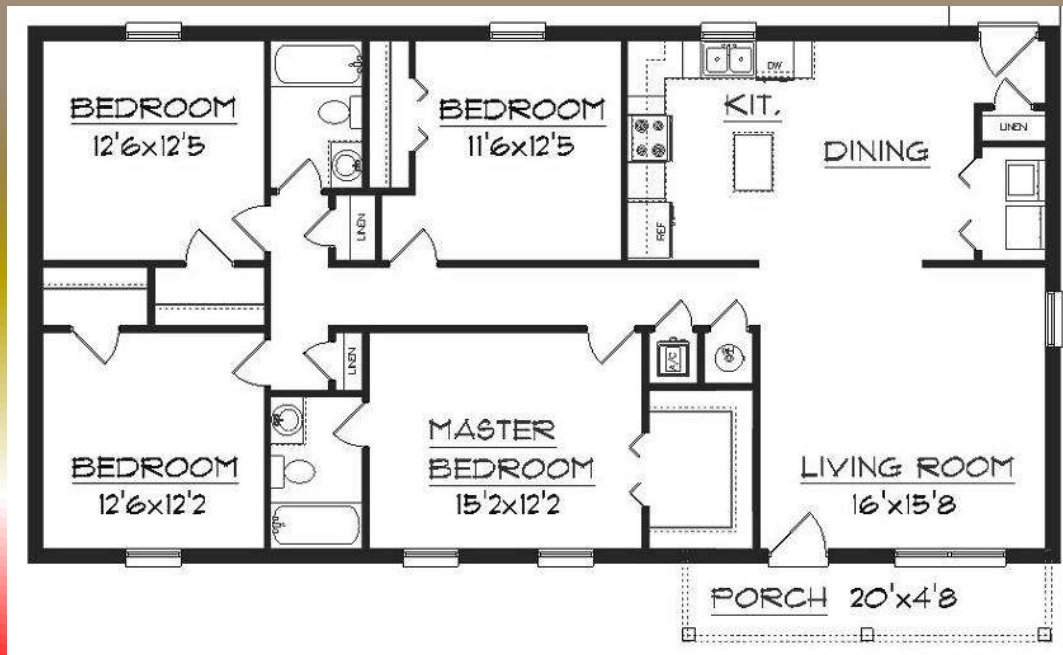

- A floor plan is a drawing of the rooms and spaces in a structure or building. Similar to a map, in an floor plan the viewer is looking downward from above.
 - Dimensions are usually drawn between the walls to specify room sizes and wall lengths.
 - Floor plans will also include details like sinks, water heaters, furnaces, etc.

Architectural Plans – Floor Plan

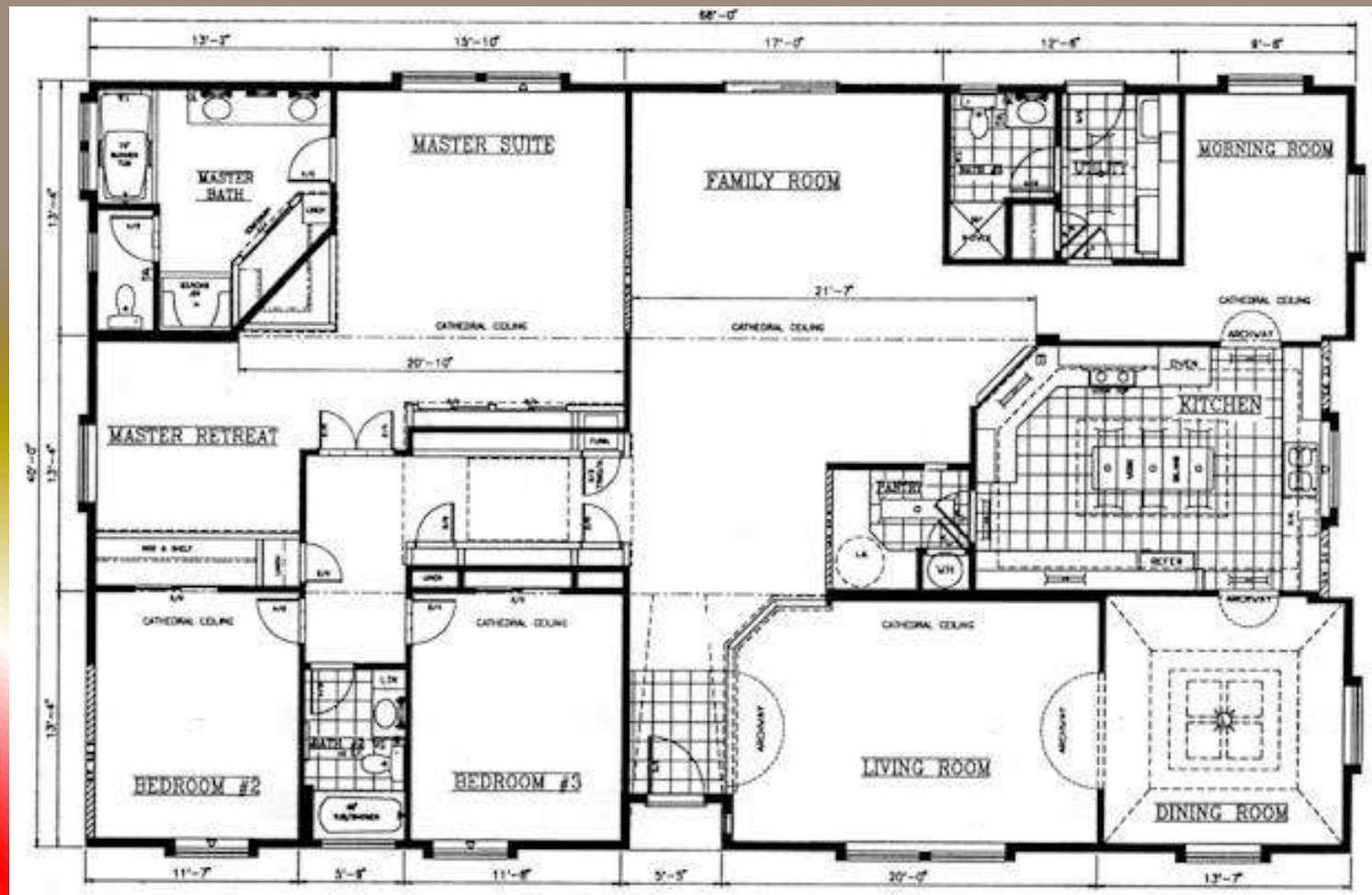

Architectural Plans – Floor Plan

□ Some of the symbols used in floor plans.



Window



Pair of Windows



French or Twin Doors



Sliding Doors



Accordion-Fold
Doors



Pocket Doors



Bi-Fold Doors

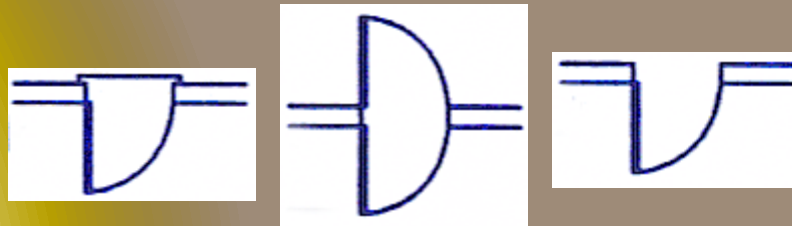

Regular Doors



Architectural Plans – Floor Plan

□ Can you find some of these symbols used in this floor plan?

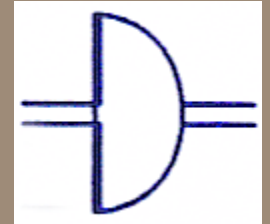
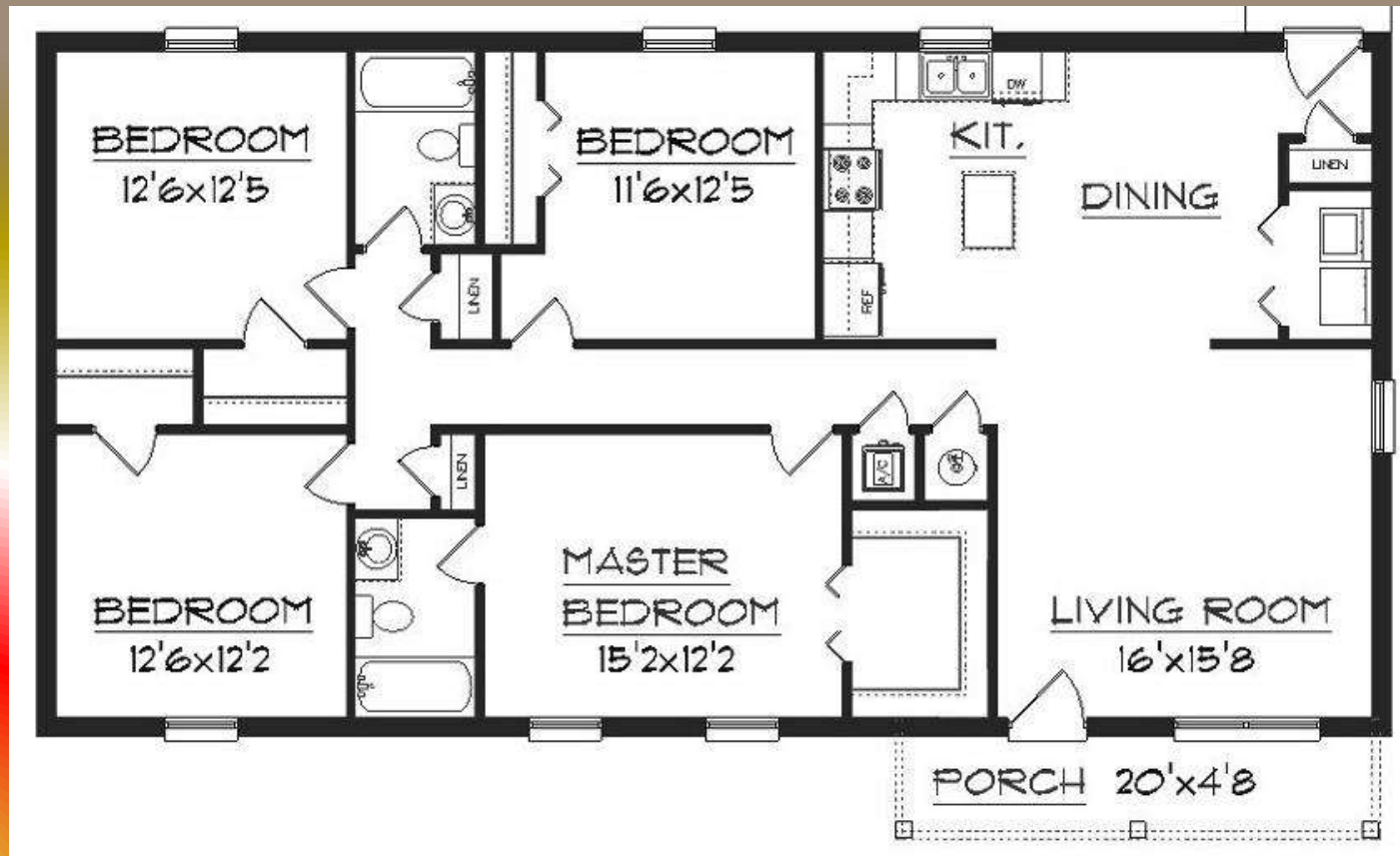

Doors

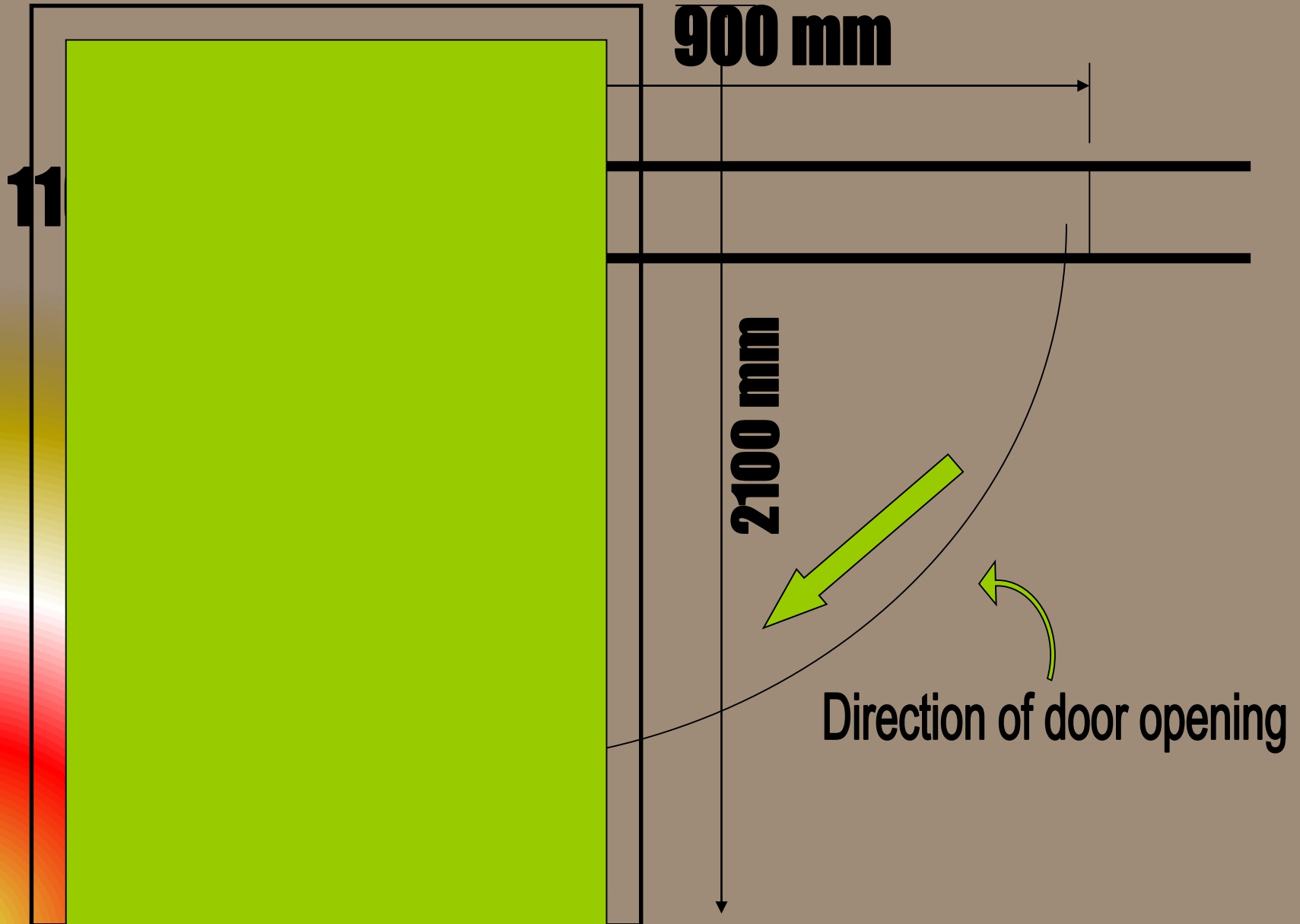

Showers

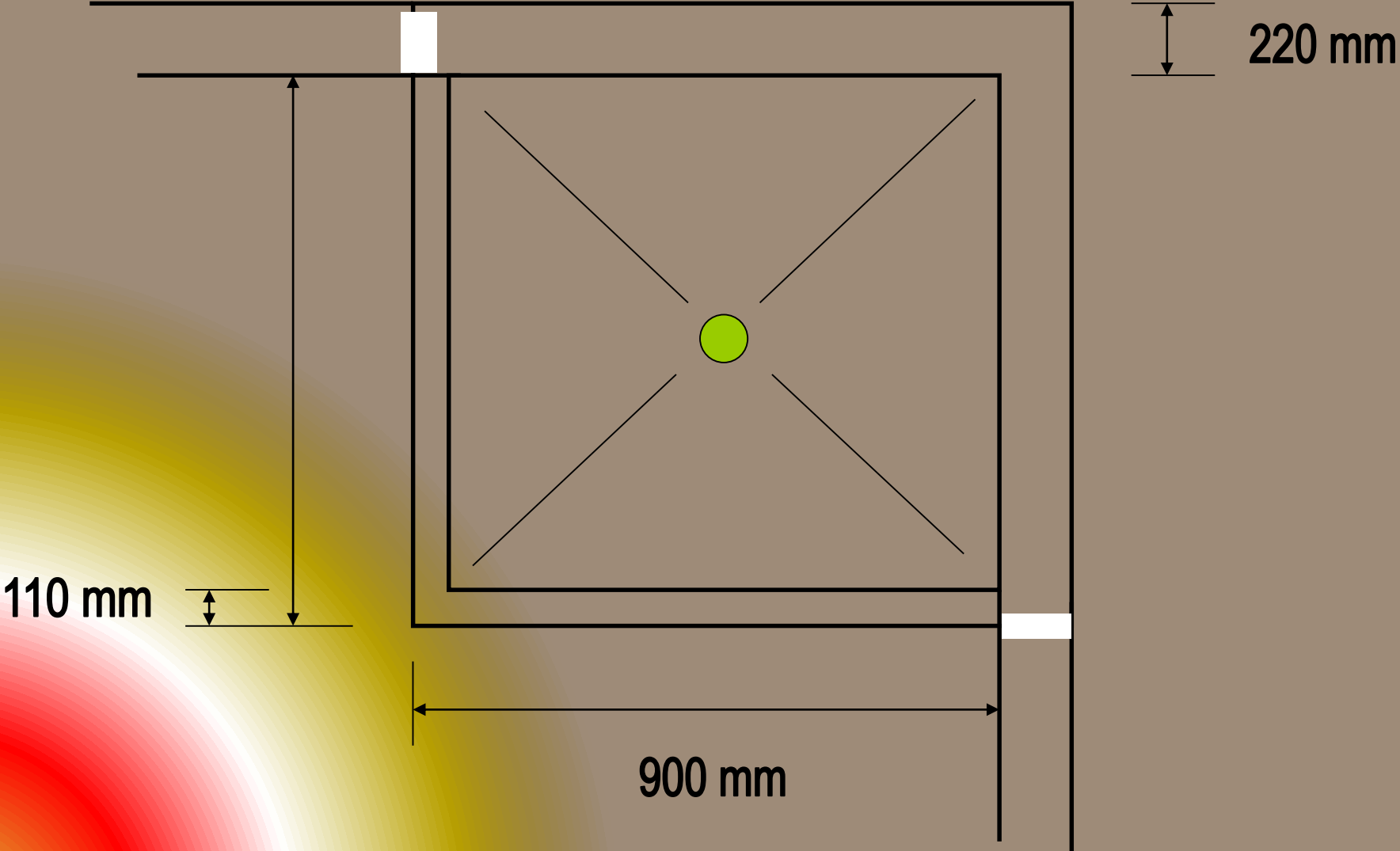

Kitchen Sink

STANDARD SIZES

900mm, 1200mm, 1500mm,
1800mm, 2100 mm

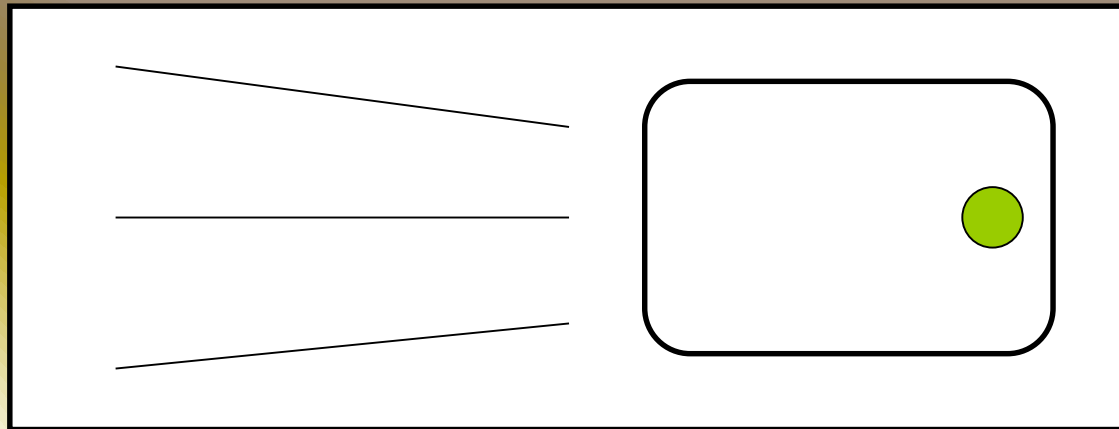

Basin

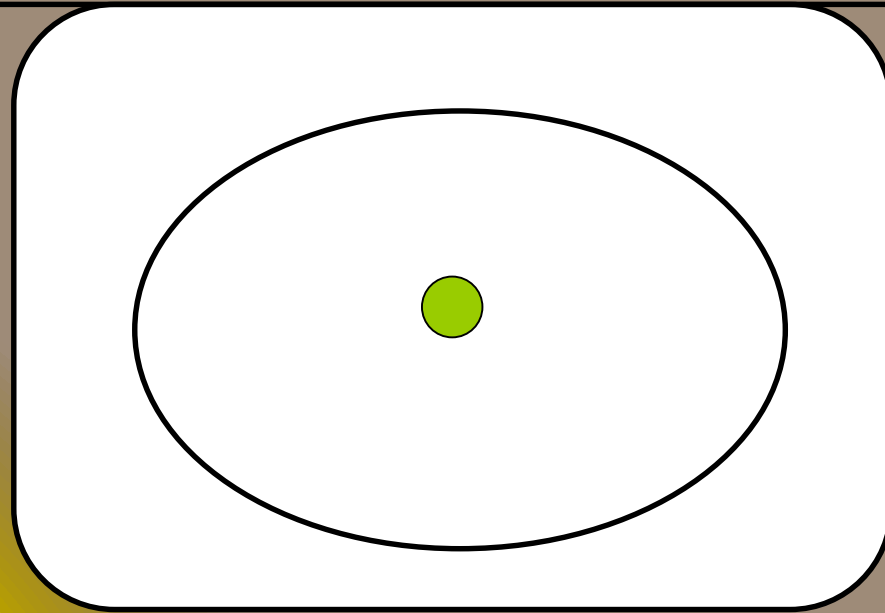

600 mm

Toilet

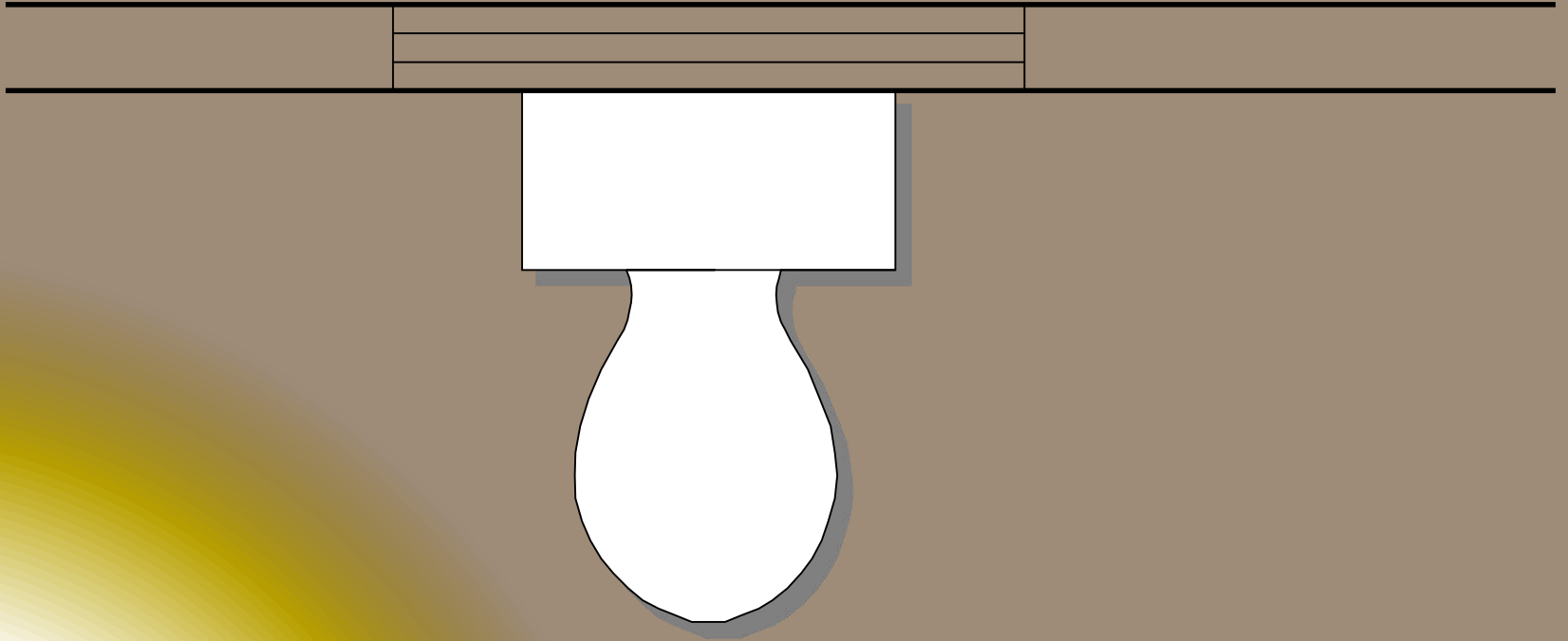

Elevations

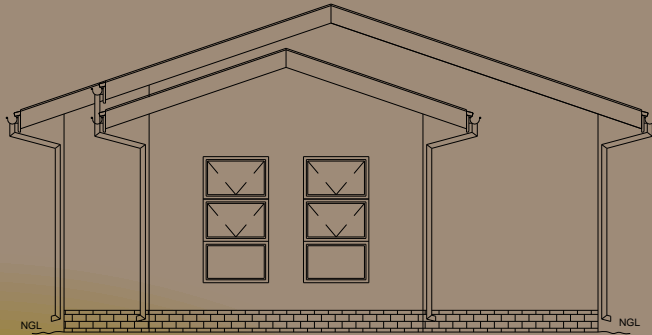

NORTH ELEVATION

SCALE 1:100

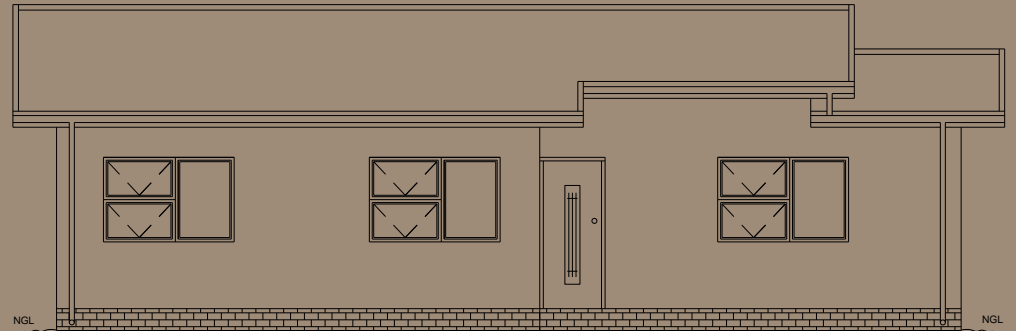

EAST ELEVATION

SCALE 1:100

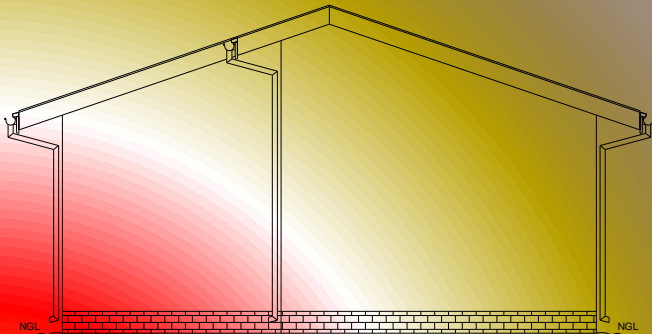

SOUTH ELEVATION

SCALE 1:100

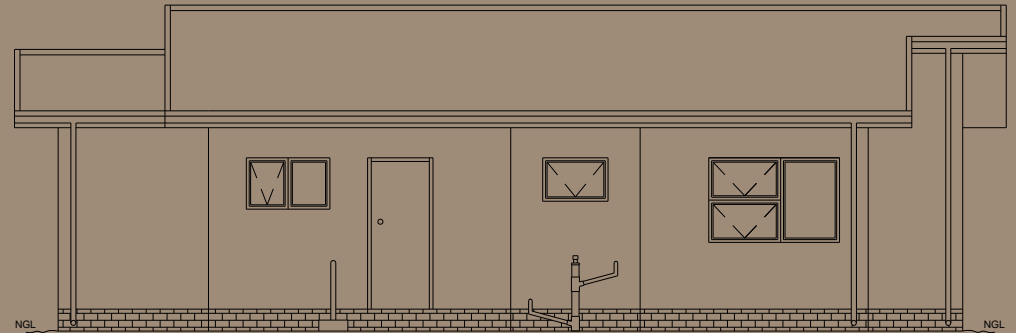

WEST ELEVATION

SCALE 1:100

Basic Symbols - Walls

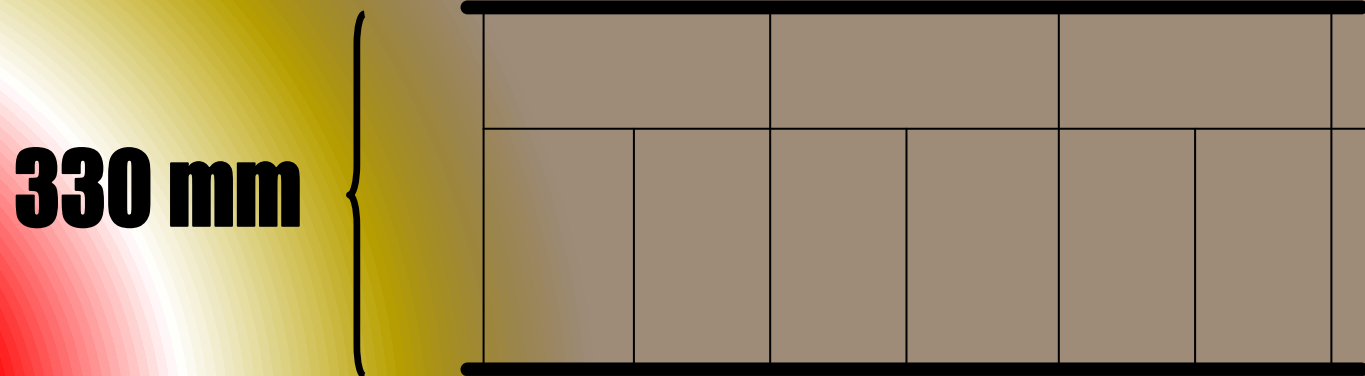

Fixtures, Appliances and Symbols

- More detailed floor plans show the layout of kitchens and bathrooms, since these are rooms which have fixtures and appliances. BSI symbols are used to simplify the drawing of common features.



Lamp



Switch



Socket

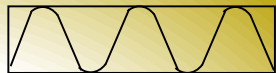

Insulation



Brickwork



Concrete



Sawn wood

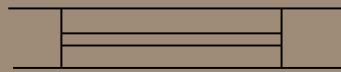

Window



Door



Radiator

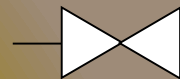

In-line valve



Crossover

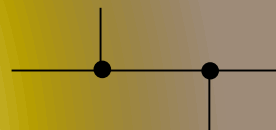

Junctions



Sink

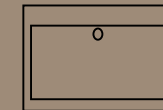

Washbasin



Shower tray

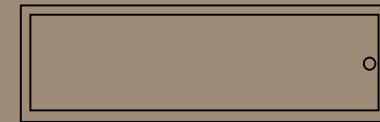

Bath

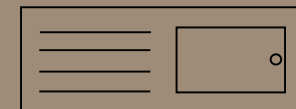

Sink top

Task – Floor Plans and Sectional Views

- Produce an accurate floor plan of a room in your home using the correct symbols learnt in this section.
 - Duration: 20mins
- Should you wish you may re-visit your kitchen floor plan and improve.

Sectional View

- A cross-section showing a slice through the wall gives builders, joiners and roofers a great deal of information about how the house should be built,
- Sections can be shown through any part of the building and normally a scale of 1:20 is used. The local building control department needs sectional views and floor plans to assess the quality of construction design.

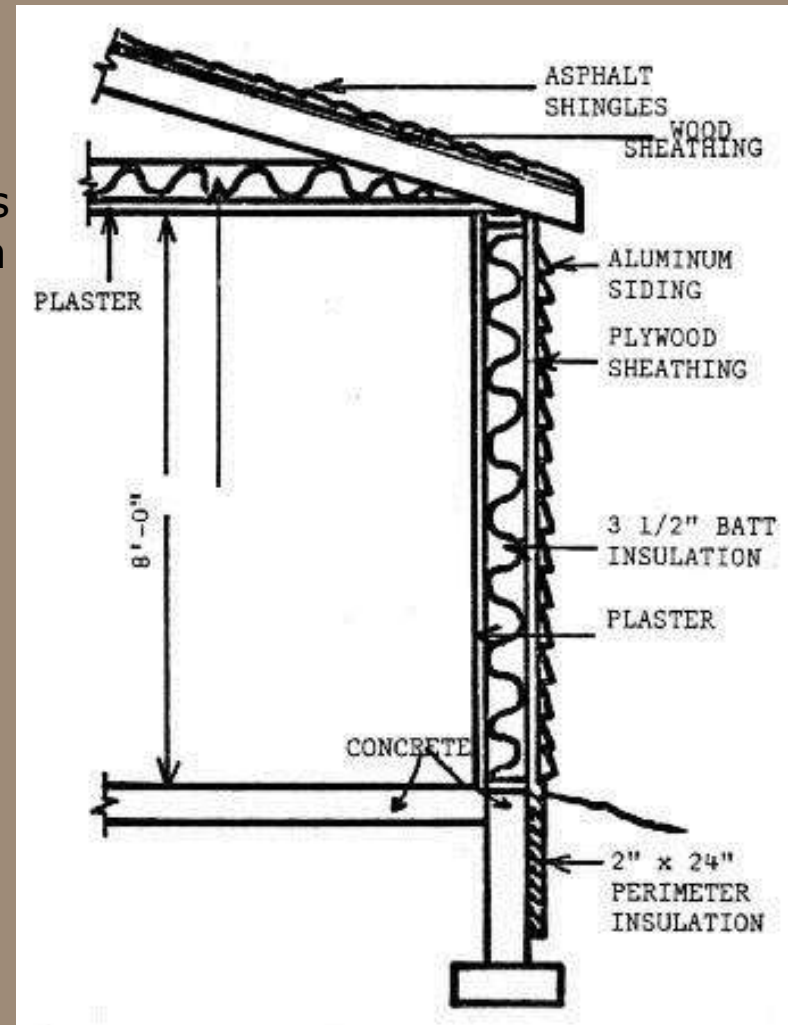

Elevations

- Elevations are orthographic projections of a building produced by its architect or designer.

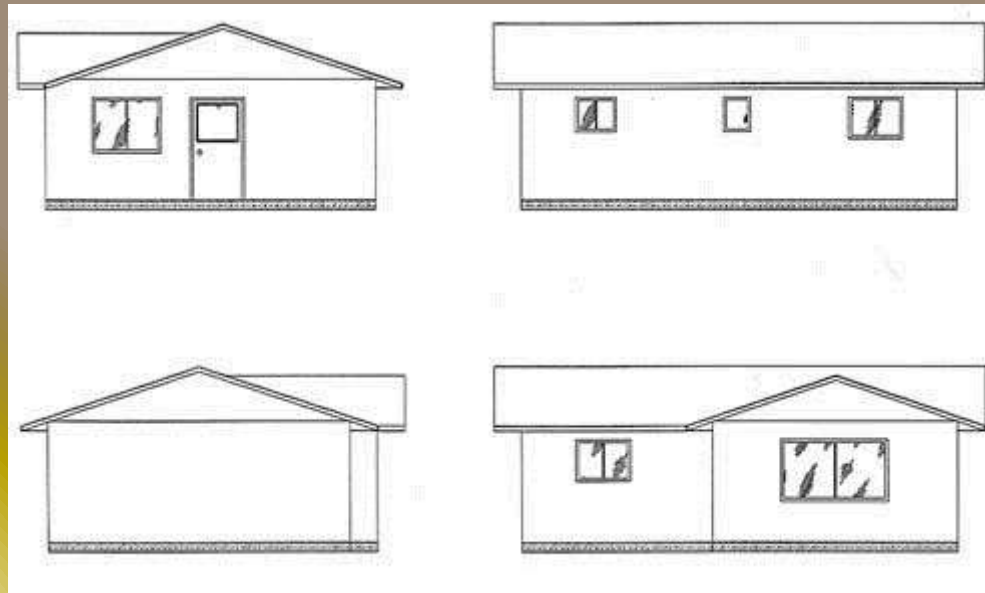

- Elevations are required by the local planning department to assess whether the style and proportions of the proposed building are appropriate for the location. Builders also need a picture of what the house will look like from the outside.

THANK YOU.....

For more detail contact us