

## **DC Machine: Construction and their Applications**

The DC machine can be classified into two types namely DC motors **as well as DC** generators. Most of the DC machines are equivalent to AC machines because they include AC currents as well as AC voltages in them. The output of the DC machine is DC output because they convert AC voltage to DC voltage. The conversion of this mechanism is known as the commutator, thus these machines are also named as commutating machines. DC machine is most frequently used for a motor. The main benefits of this machine include torque regulation as well as easy speed. The **applications of the DC machine** are limited to trains, mills, and mines. As examples, underground subway cars, as well as trolleys, may utilize DC motors. In the past, automobiles were designed with DC dynamos for charging their batteries.

### **DC Machine**

A DC machine is an electromechanical energy alteration device. The **working principle of a DC machine** is when electric current flows through a coil within a magnetic field, and then the magnetic force generates a torque which rotates the dc motor. The DC machines are classified into two types such as DC generator as well as DC motor. The main function

of the DC generator is to convert mechanical power to DC electrical power, whereas a DC motor converts DC power to mechanical power. The **AC motor** is frequently used in the industrial applications for altering electrical energy to mechanical energy. However, a DC motor is applicable where the good speed regulation & ample range of speeds are necessary like in electric-transaction systems.

## **Construction of DC Machine**

The construction of DC machine can be done using some of the essential parts like Yoke, Pole core & pole shoes, Pole coil & field coil, Armature core, Armature winding otherwise conductor, commutator, brushes & bearings. Some of the **parts of the DC machine** is discussed below.

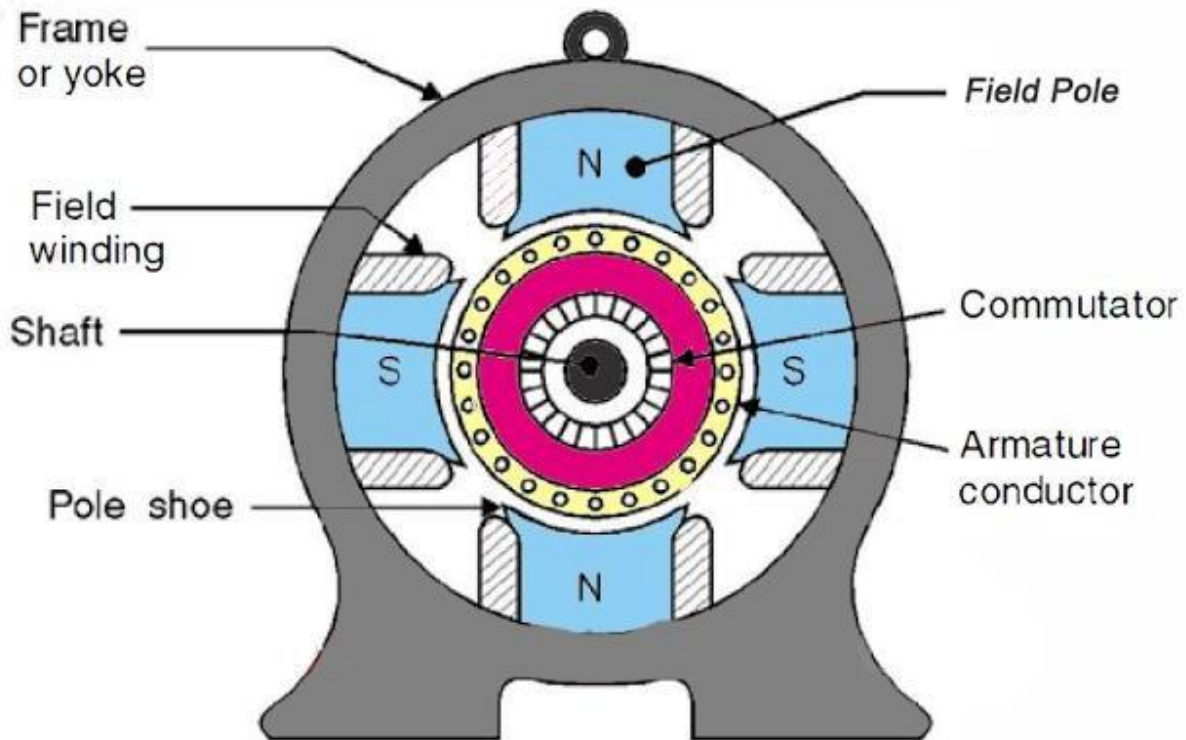

### **Yoke**

Another name of a yoke is the frame. The main function of the yoke in the machine is to offer mechanical support intended for poles and protects the entire machine from the moisture, dust, etc. The materials used in the yoke are designed with cast iron, cast steel otherwise rolled steel.

### **Pole and Pole Core**

The pole of the DC machine is an electromagnet and the field winding is winding among pole. Whenever field winding is energized then the pole gives magnetic flux. The materials used for this are cast steel, cast iron otherwise pole core. It

can be built with the annealed steel laminations for reducing the power drop because of the eddy currents.

### **Pole Shoe**

Pole shoe in DC machine is an extensive part as well as enlarge the region of the pole. Because of this region, flux can be spread out within the air-gap as well as extra flux can be passed through the air space toward armature. The materials used to build pole shoe is cast iron otherwise cast steel, and also used annealed steel lamination to reduce the loss of power because of eddy currents.

### **Field Windings**

In this, the windings are wound in the region of pole core & named as field coil. Whenever current is supplied through field winding then it electromagnetics the poles which generate required flux. The material used for field windings is copper.

### **Armature Core**

Armature core includes the huge number of slots within its edge. Armature conductor is located in these slots. It provides

the low-reluctance path toward the flux generated with field winding. The materials used in this core are permeability low-reluctance materials like iron otherwise cast. The lamination is used to decrease the loss because of the eddy current.

### **Armature Winding**

The armature winding can be formed by interconnecting the armature conductor. Whenever an armature winding is turned with the help of prime mover then the voltage, as well as magnetic flux, gets induced within it. This winding is allied to an exterior circuit. The materials used for this winding are conducting material like copper.

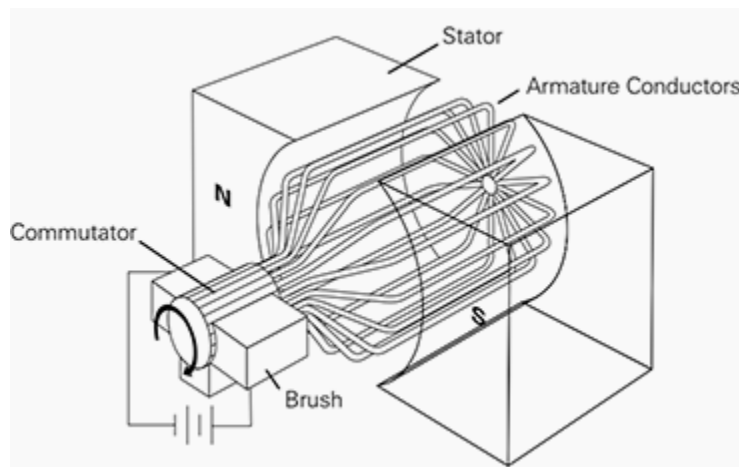

## **Commutator**

The main function of the commutator in the DC machine is to collect the current from the armature conductor as well as supplies the current to the load using brushes. And also provides uni-directional torque for DC-motor. The commutator can be built with a huge number of segments in the edge form of hard drawn copper. The Segments in the commutator are protected from thin mica layer.

## **Brushes**

Brushes in the DC machine gather the current from commutator and supplies it to exterior load. Brushes wear with time to inspect frequently. The materials used in brushes are graphite otherwise carbon which is in rectangular form.

## **Types of DC Machines**

The excitation of the DC machine is classified into two types namely separate excitation, as well as self-excitation. In separate excitation type of dc machine, the field coils are activated with a separate DC source. In self-excitation type of dc machine, the flow of current throughout the field-winding is supplied with the machine. The principal kinds of DC machine are classified into four types which include the following.

- Separately excited DC machine
- Shunt wound/shunt machine.
- Series wound/series machine.
- Compound wound / compound machine.

### **Separately Excited DC Machine**

In Separately Excited DC Machine, a separate DC source is utilized for activating the field coils.

### **Shunt Wound DC Machine**

In Shunt wound DC Machines, the field coils are allied in parallel through the armature. As the shunt field gets the complete o/p voltage of a generator otherwise a motor supply voltage, it is normally made of a huge number of twists of fine wire with a small field current carrying.

In series wound D.C. Machines, the field coils are allied in series through the armature. As series field winding gets the armature current, as well as the armature current is huge, due to this the series field winding includes few twists of wire of big cross-sectional region.

### **Compound Wound DC Machine**

A compound machine includes both the series as well as shunt fields. The two windings are carried-out with every machine pole. The series winding of the machine includes few

twists of a huge cross-sectional region, as well as the shunt windings, include several fine wire twists.

The connection of the compound machine can be done in two ways. If the shunt-field is allied in parallel by the armature only, then the machine can be named as the 'short shunt compound machine' & if the shunt-field is allied in parallel by both the armature as well as series field, then the machine is named as the 'long shunt compound machine'.

### **Series Wound DC Machine**

In series wound D.C. Machines, the field coils are allied in series through the armature. As series field winding gets the armature current, as well as the armature current is huge, due to this the series field winding includes few twists of wire of big cross-sectional region.

### **Compound Wound DC Machine**

A compound machine includes both the series as well as shunt fields. The two windings are carried-out with every machine pole. The series winding of the machine includes few

twists of a huge cross-sectional region, as well as the shunt windings, include several fine wire twists.

The connection of the compound machine can be done in two ways. If the shunt-field is allied in parallel by the armature only, then the machine can be named as the 'short shunt compound machine' & if the shunt-field is allied in parallel by both the armature as well as series field, then the machine is named as the 'long shunt compound machine'.

### **Characteristics of DC motors**

Generally, three characteristic curves are considered important for DC motors which are, (i) Torque vs. armature current, (ii) Speed vs. armature current and (iii) Speed vs. torque. These are explained below for each type of DC motor. These characteristics are determined by keeping the following two relations in mind.

$$T_a \propto \phi \cdot I_a \text{ and } N \propto E_b / \phi$$

For a DC motor, magnitude of the back emf is given by the same emf equation of a dc generator i.e.  $E_b = \frac{P\phi NZ}{60A}$ . For a machine, P, Z and A are constant, therefore,  $N \propto E_b / \phi$

# Characteristics of DC series

## motors

### ***Torque vs. armature current ( $T_a-I_a$ )***

This characteristic is also known as **electrical characteristic**. We know that torque is directly proportional to the product of armature current and field flux,  $T_a \propto \phi \cdot I_a$ . In DC series motors, field winding is connected in series with the armature, i.e.  $I_a = I_f$ . Therefore, before magnetic saturation of the field, flux  $\phi$  is directly proportional to  $I_a$ . Hence, before magnetic saturation  $T_a \propto I_a^2$ . Therefore, the  $T_a-I_a$  curve is parabola for smaller values of  $I_a$ .

After magnetic saturation of the field poles, flux  $\phi$  is independent of armature current  $I_a$ . Therefore, the torque varies proportionally to  $I_a$  only,  $T_a \propto I_a$ . Therefore, after magnetic saturation,  $T_a-I_a$  curve becomes a straight line.

The shaft torque ( $T_{sh}$ ) is less than armature torque ( $T_a$ ) due to stray losses. Hence, the curve  $T_{sh}$  vs  $I_a$  lies slightly lower.

In DC series motors, (prior to magnetic saturation) torque increases as the square of armature current, these motors are used where high starting torque is required.

### ***Speed vs. armature current ( $N-I_a$ )***

We know the relation,  $N \propto E_b/\phi$

For small load current (and hence for small armature current) change in back emf  $E_b$  is small and it may be neglected. Hence, for small currents speed is inversely proportional to  $\phi$ . As we know, flux is directly proportional to  $I_a$ , speed is inversely proportional to  $I_a$ .

Therefore, when armature current is very small the speed becomes dangerously high. That is **why a series motor should never be started without some mechanical load**.

But, at heavy loads, armature current  $I_a$  is large. And hence, speed is low which results in decreased back emf  $E_b$ . Due to decreased  $E_b$ , more armature current is allowed.

## **Speed vs. torque (N-Ta)**

This characteristic is also called as **mechanical characteristic**. From the above two **characteristics of DC series motor**, it can be found that when speed is high, torque is low and vice versa.

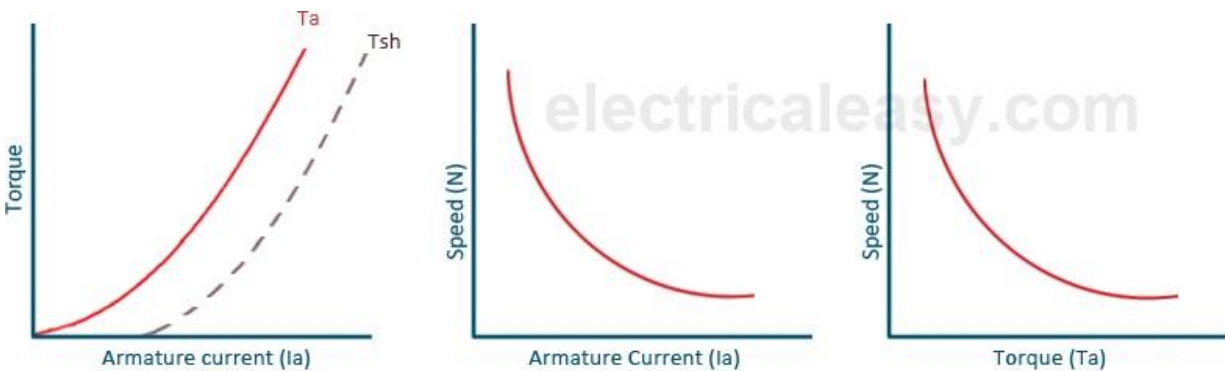

Characteristics of DC series motor

## **Characteristics of DC shunt motors**

### **Torque vs. armature current ( $T_a-I_a$ )**

In case of DC shunt motors, we can assume the field flux  $\phi$  to be constant. Though at heavy loads,  $\phi$  decreases in a small amount due to increased **armature reaction**. As we are neglecting the change in the flux  $\phi$ , we can say that torque is proportional to armature current. Hence, the  $T_a-I_a$  characteristic for a dc shunt motor will be a straight line through the origin.

Since heavy starting load needs heavy starting current, **shunt motor**

should never be started on a heavy load.

### **Speed vs. armature current (N-Ia)**

As flux  $\phi$  is assumed to be constant, we can say  $N \propto E_b$ . But, as back emf is also almost constant, the speed should remain constant. But practically,  $\phi$  as well as  $E_b$  decreases with increase in load. Back emf  $E_b$  decreases slightly more than  $\phi$ , therefore, the speed decreases slightly. Generally, the speed decreases only by 5 to 15% of full load speed. Therefore, **a shunt motor can be assumed as a constant speed motor**. In speed vs. armature current characteristic in the following figure, the straight horizontal line represents the ideal characteristic and the actual characteristic is shown by the dotted line.

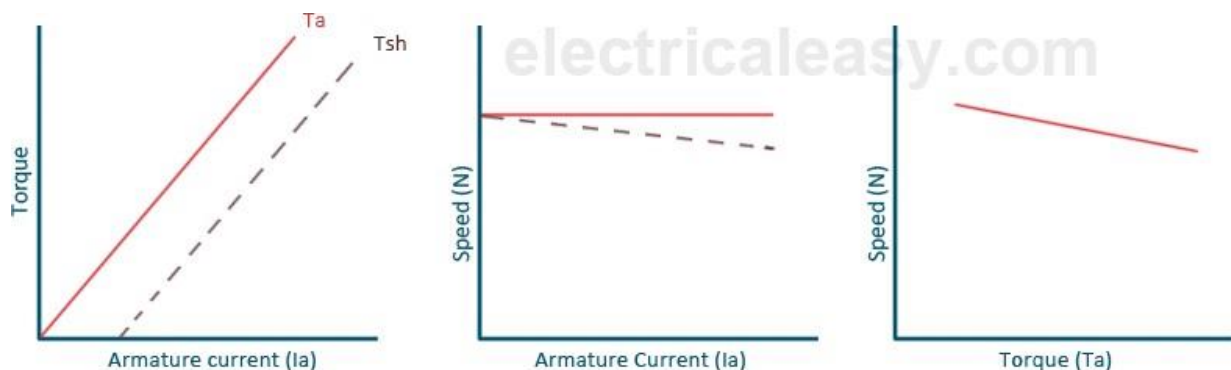

Characteristics of DC shunt motor

### **Characteristics of DC compound motor**

DC compound motors have both series as well as shunt winding. In a compound motor, if series and shunt windings are connected such

that series flux is in direction as that of the shunt flux then the motor is said to be cumulatively compounded. And if the series flux is opposite to the direction of the shunt flux, then the motor is said to be differentially compounded. Characteristics of both these compound motors are explained below.

**(a) Cumulative compound motor**

Cumulative compound motors are used where series characteristics are required but the load is likely to be removed completely. Series winding takes care of the heavy load, whereas the shunt winding prevents the motor from running at dangerously high speed when the load is suddenly removed. These motors have generally employed a flywheel, where sudden and temporary loads are applied like in rolling mills.

**(b) Differential compound motor**

Since in differential field motors, series flux opposes shunt flux, the total flux decreases with increase in load. Due to this, the speed remains almost constant or even it may increase slightly with increase in load ( $N \propto E_b/\phi$ ). Differential compound motors are not commonly used, but they find limited applications in experimental and research work.

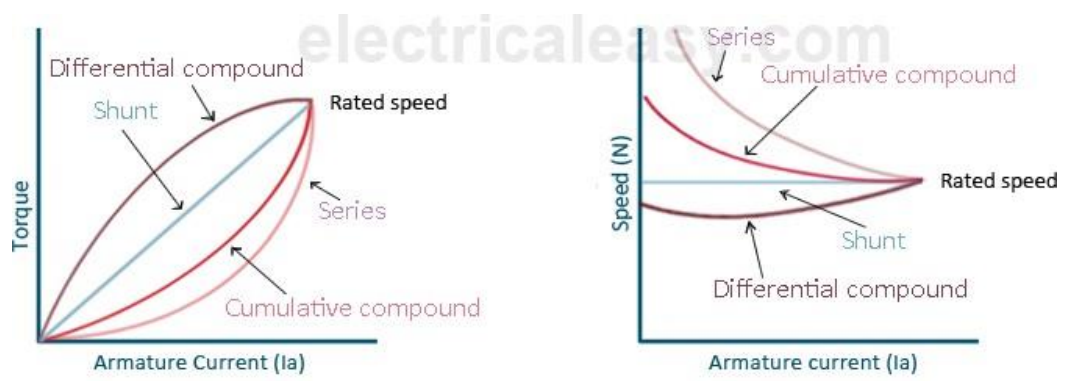

## Characteristics of DC compound motor

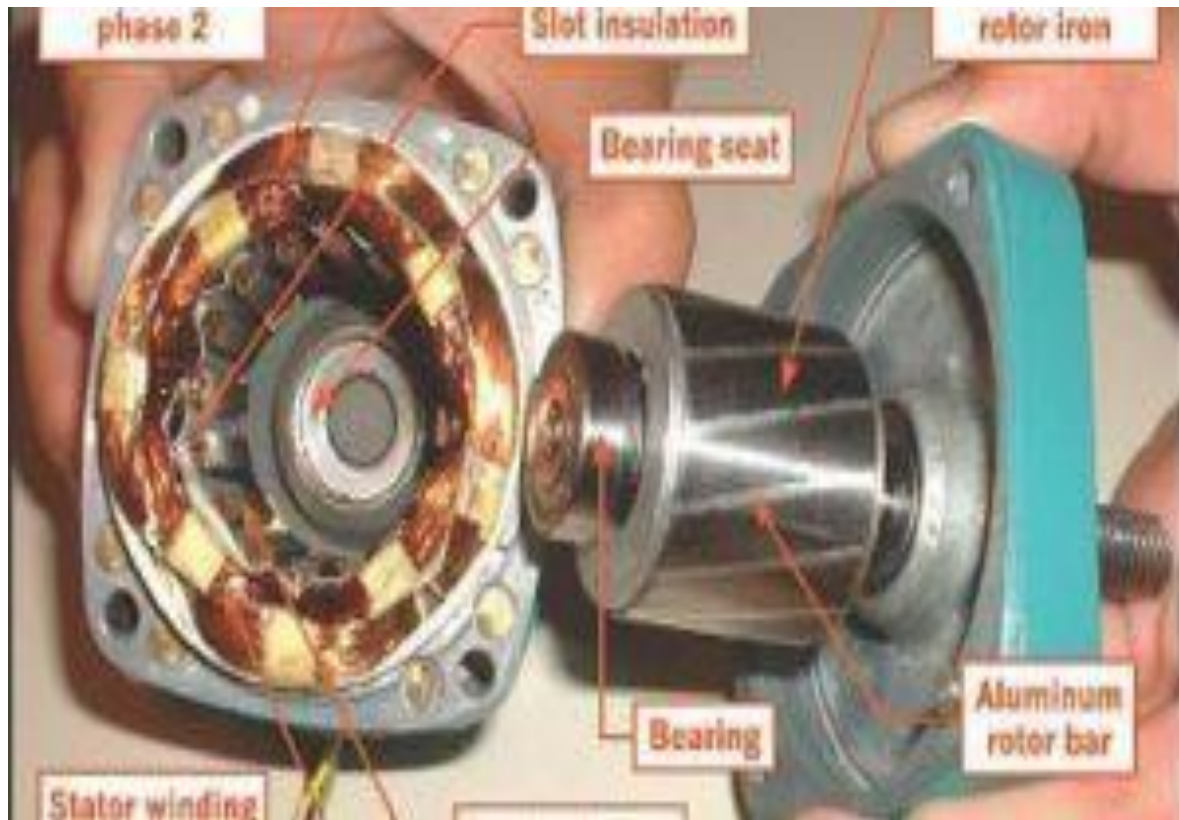

The frame is used as an outer protecting cover that is used to protect against environmental conditions. The frame also acts as an outer periphery such that the inner parts can be easily housed. The stable state section of the equipment is stator on which the stator winding is enclosed.

The rotor is the moving part that either move in clockwise or anti-clockwise depending upon thrust impelled on it. The bearings provide proper friction for the rotor to run smoothly. A fan is employed to remove the unwanted heat that gained during the running of the rotor. It is expelled out through the ventilation that is provided behind the machine. A shaft is provided to deliver the mechanical output as the rotor rotates. The slips rings are employed for a normal Ac machine where rotating armature stationary field winding is employed. In this

situation, the slip rings allow the input alternating current to change continuously in the coils

.

# Transformer

An A.C. device used to change high voltage low current A.C. into low voltage high current A.C. and vice-versa without changing the frequency

In brief,

1. Transfers electric power from one circuit to another
2. It does so without a change of frequency
3. It accomplishes this by electromagnetic induction
4. Where the two electric circuits are in mutual inductive influence of each other.

# Principle of operation

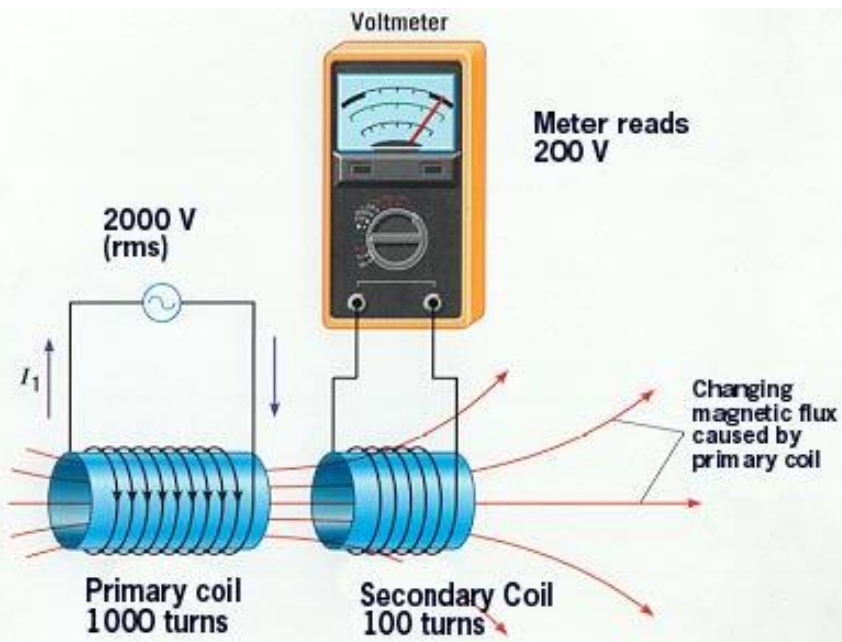

It is based on principle of **MUTUAL INDUCTION**.

According to which an e.m.f. is induced in a coil when current in the neighbouring coil changes.

# Constructional detail : **Shell type**

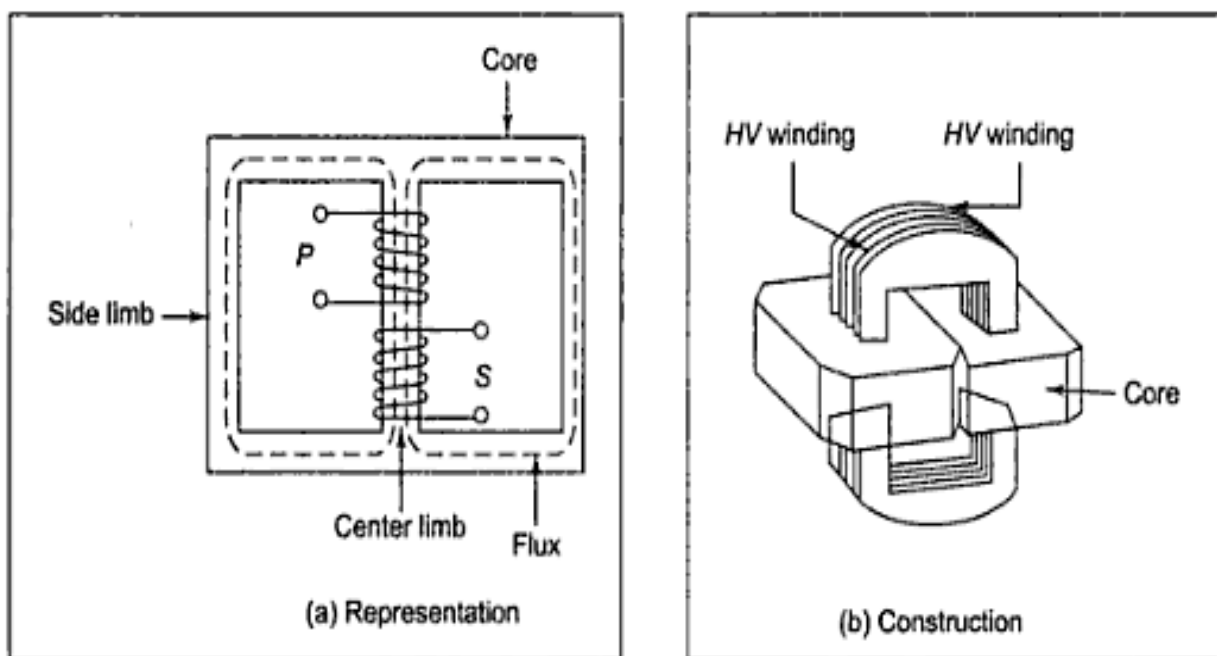

- Windings are wrapped around the center leg of a laminated core.

# Core type

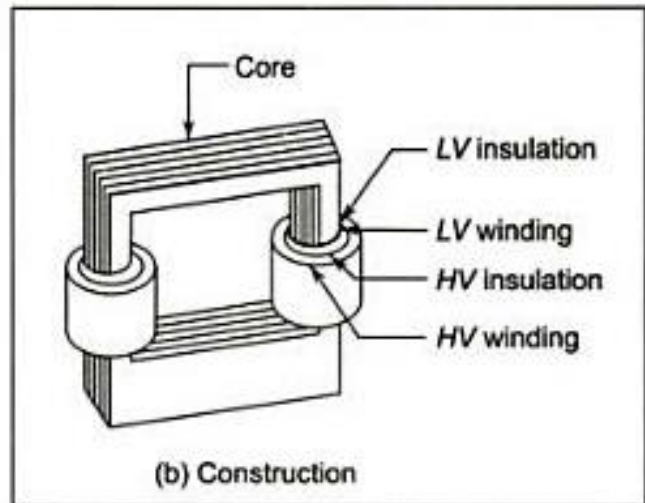
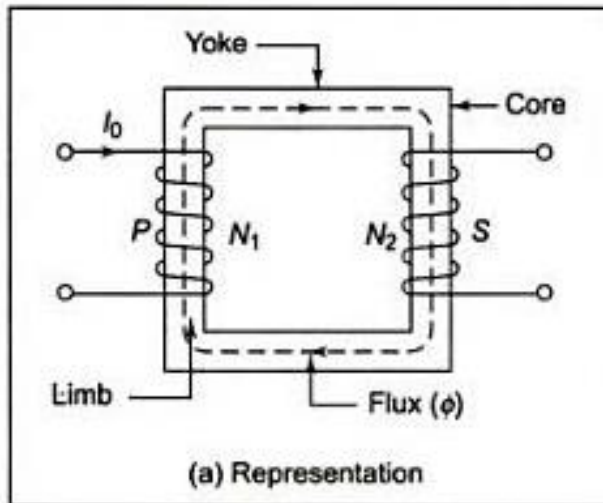

- Windings are wrapped around two sides of a laminated square core.

# Sectional view of transformers

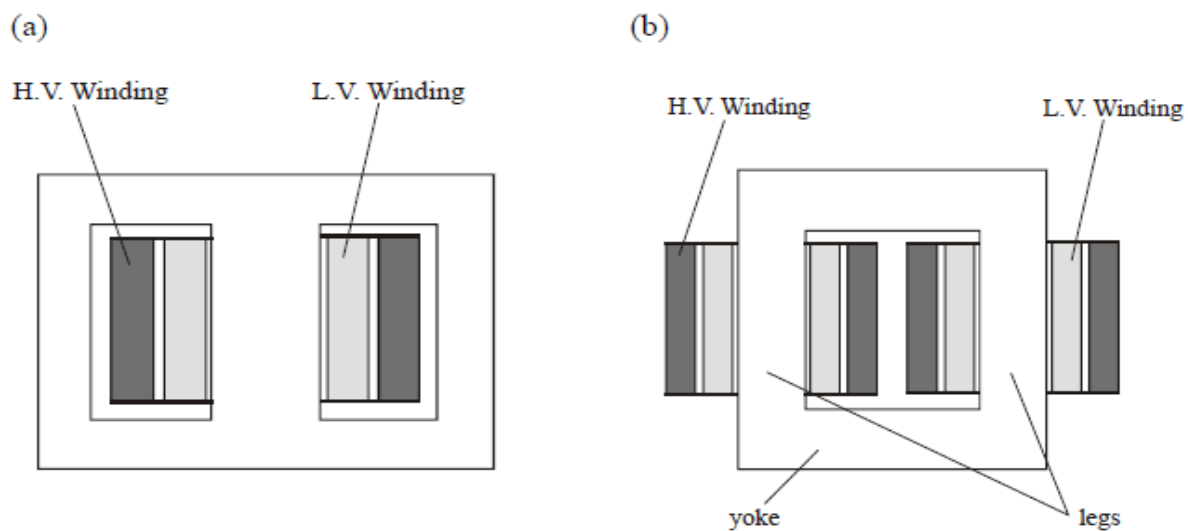

(a) Shell-type transformer, (b) core-type transformer

**Note:**

High voltage conductors are smaller cross section conductors than the low voltage coils

# Construction of transformer from stampings

(a)

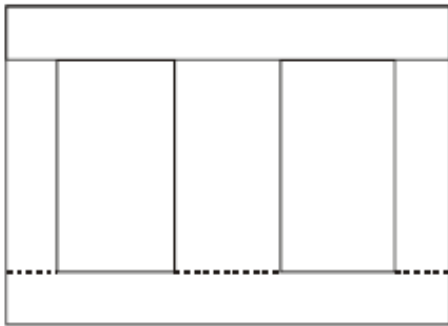

(b)

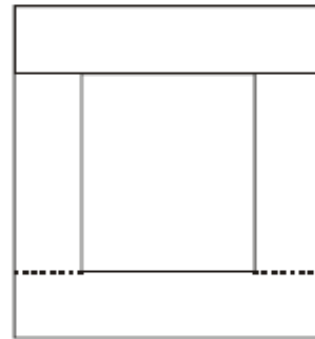

(a) Shell-type transformer, (b) core-type transformer

# Core type

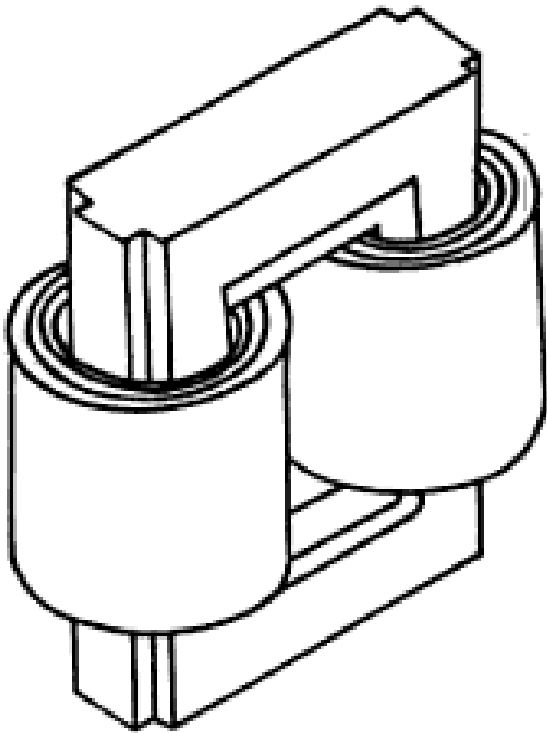

Fig1: Coil and laminations of core type transformer

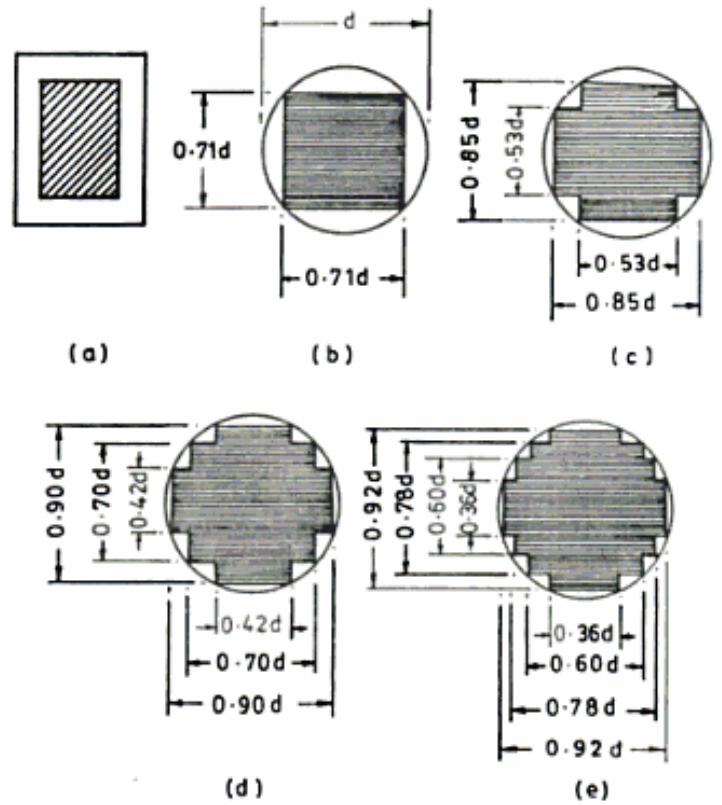

Fig2: Various types of cores

# Shell type

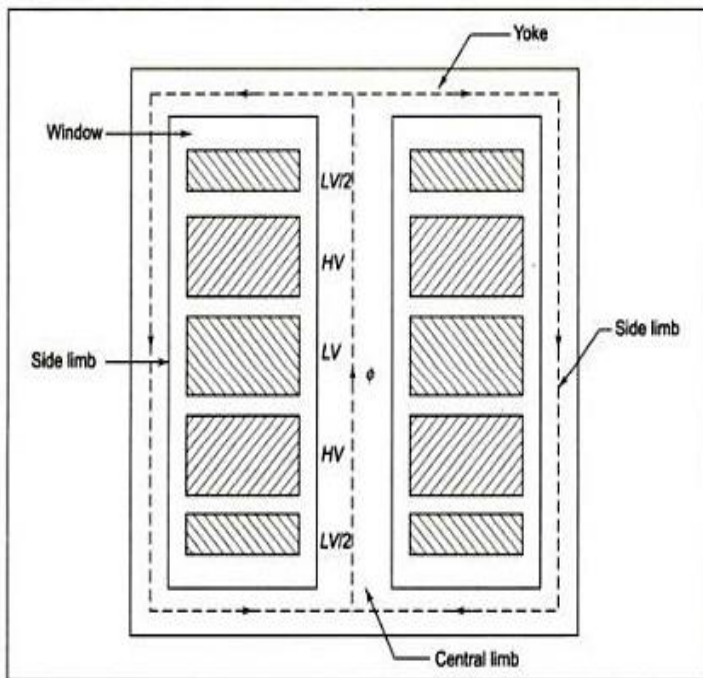
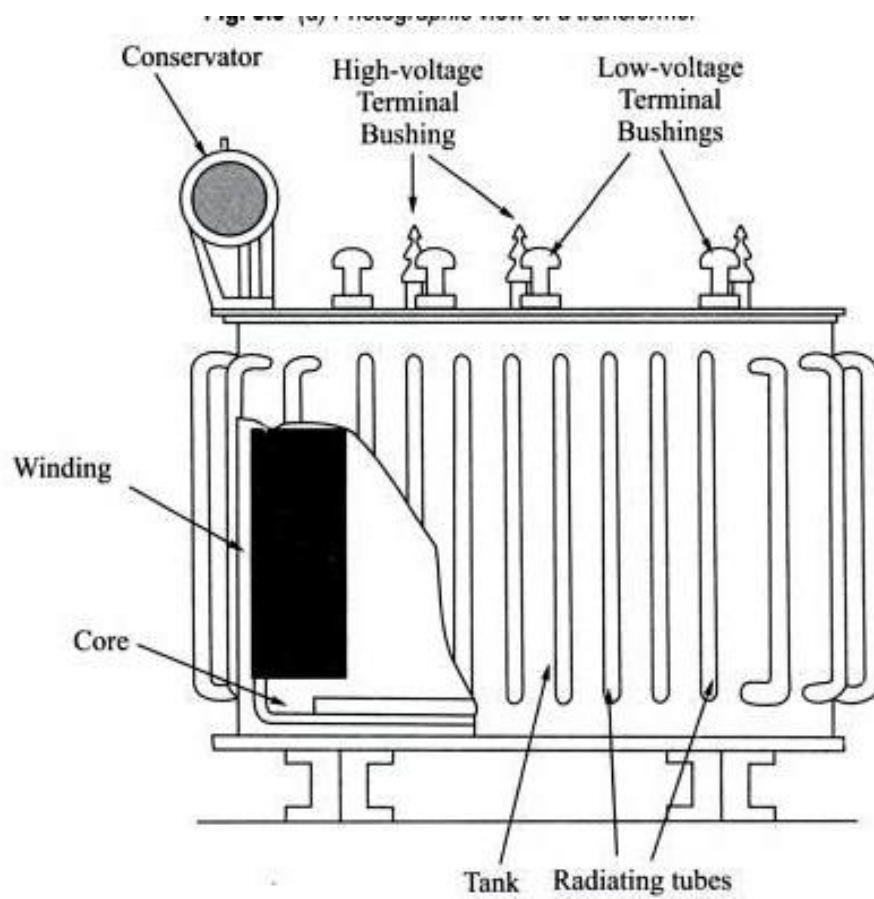

Fig: Sandwich windings

- The HV and LV windings are split into no. of sections
- Where HV winding lies between two LV windings
- In sandwich coils leakage can be controlled

# Cut view of transformer



# Transformer with conservator and breather

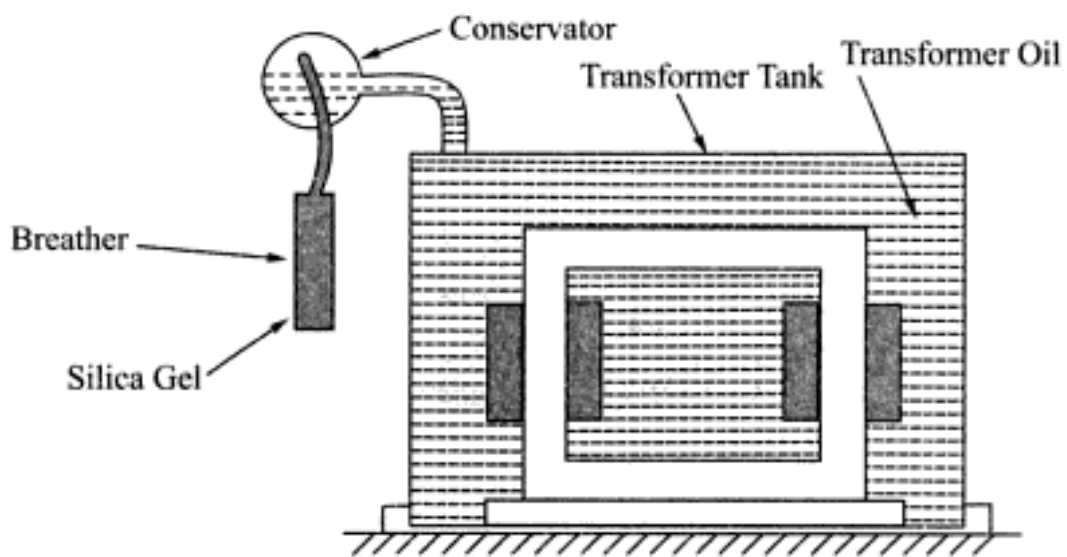

# Working of a transformer

1. When current in the primary coil changes being alternating in nature, a changing magnetic field is produced
2. This changing magnetic field gets associated with the secondary through the soft iron core
3. Hence magnetic flux linked with the secondary coil changes.
4. Which induces e.m.f. in the secondary.

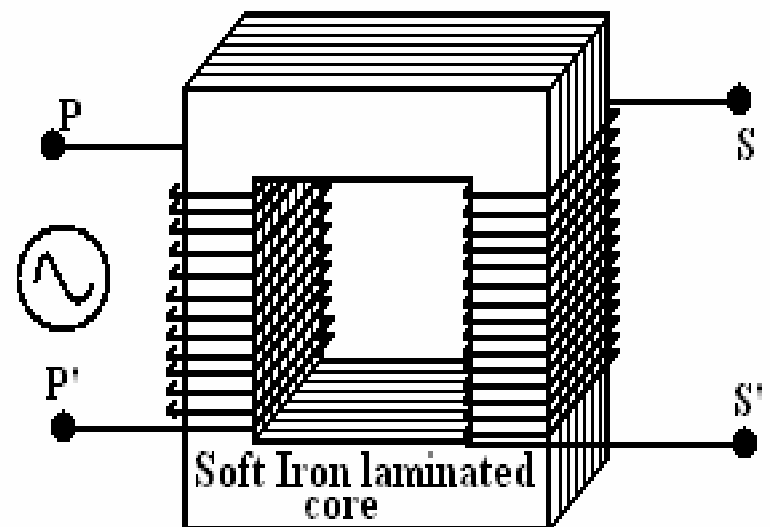

## Single Phase Transformer

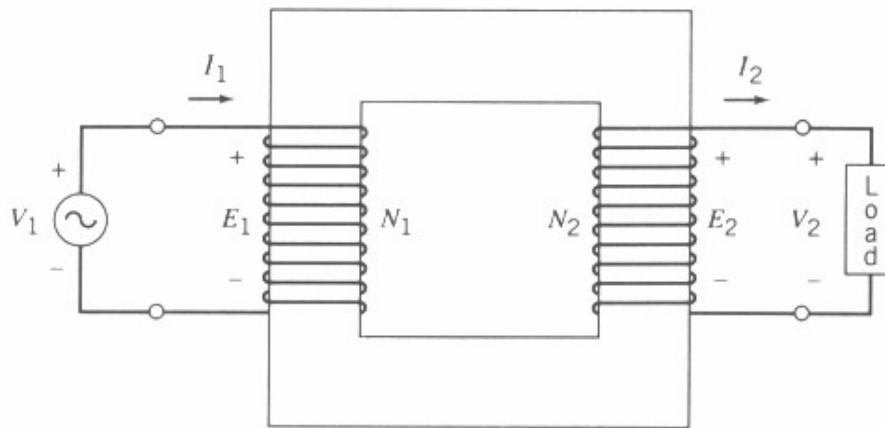

FIGURE 4.8 A transformer circuit.

- A single phase transformer
  - Two or more winding, coupled by a common magnetic core

# Ideal Transformers

- **Zero leakage flux:**
  - Fluxes produced by the primary and secondary currents are confined within the core
- **The windings have no resistance:**
  - Induced voltages equal applied voltages
- **The core has infinite permeability**
  - Reluctance of the core is zero
  - Negligible current is required to establish magnetic flux
- **Loss-less magnetic core**
  - No hysteresis or eddy currents

# Ideal transformer

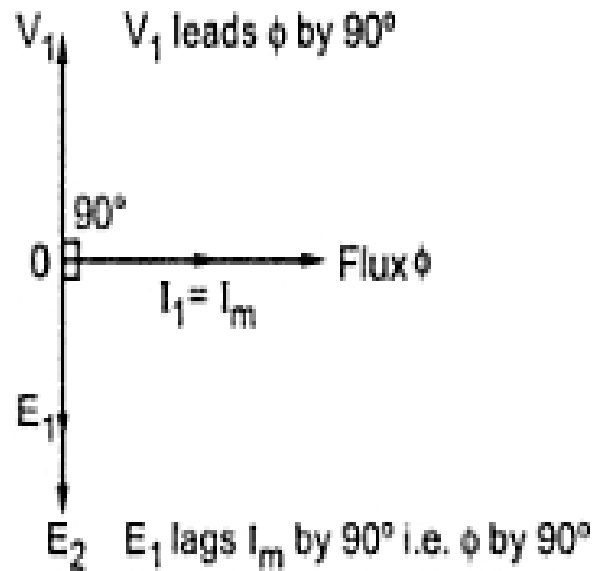
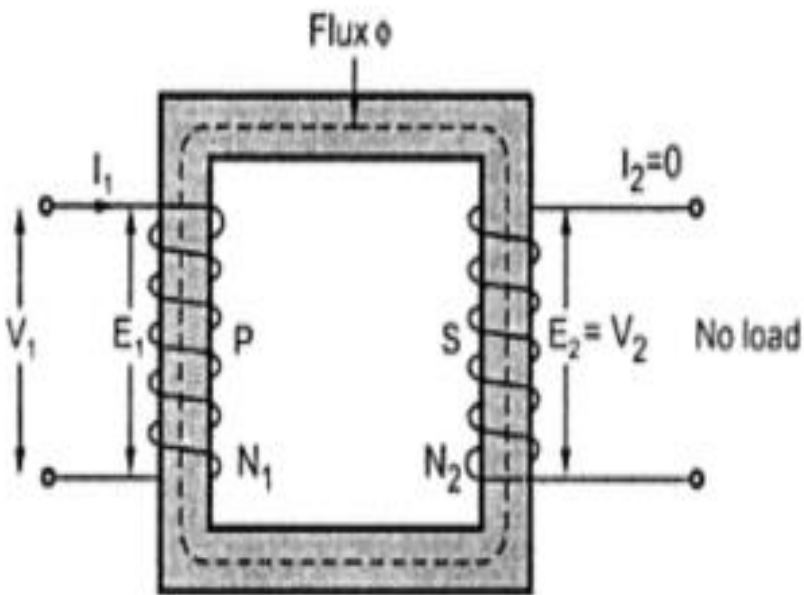

$V_1$  – supply voltage ;  
 $V_2$  – output voltage;  
 $I_m$  – magnetising current;  
 $E_1$  – self induced emf ;

$I_1$  – no-load input current ;  
 $I_2$  – output current  
 $E_2$  – mutually induced emf

# EMF equation of a transformer

- Worked out on board /
- [Refer pdf file: emf-equation-of-tranformer](#)

# Phasor diagram: Transformer on No-load

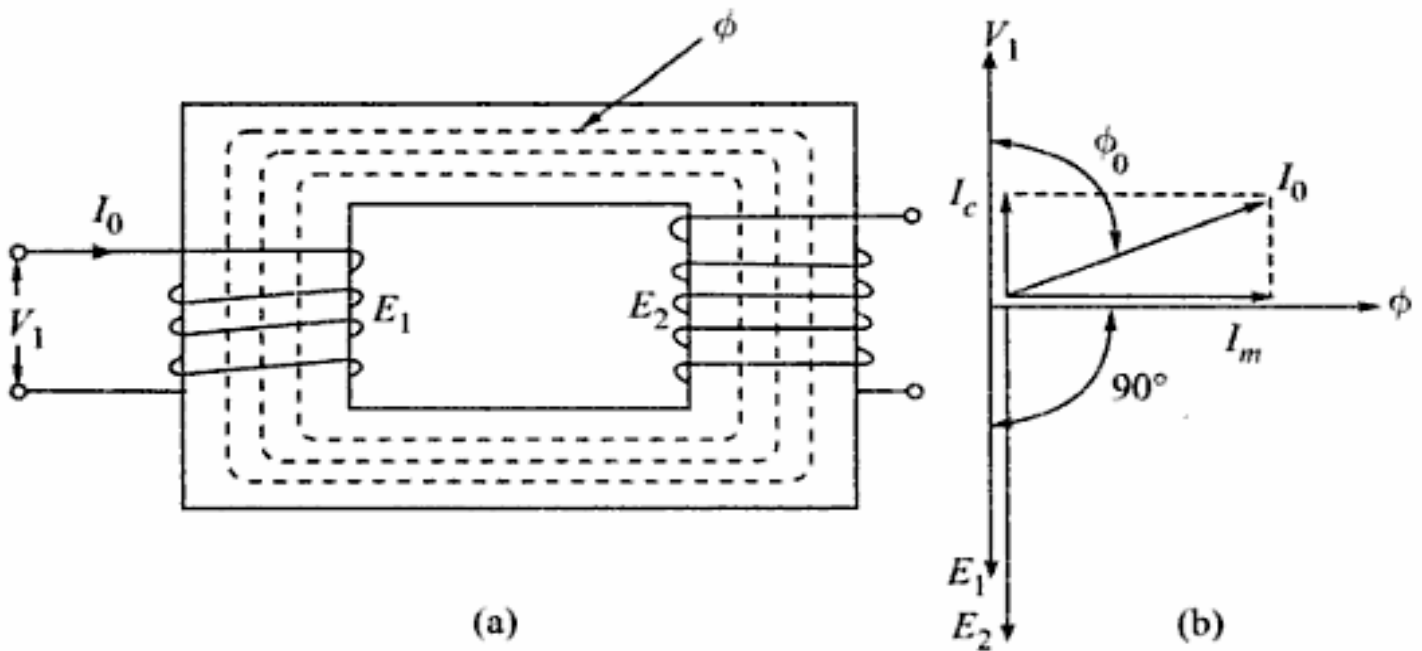

(a) Transformer on no-load (b) Phasor diagram of a transformer on no-load

# Transformer on load assuming no voltage drop in the winding

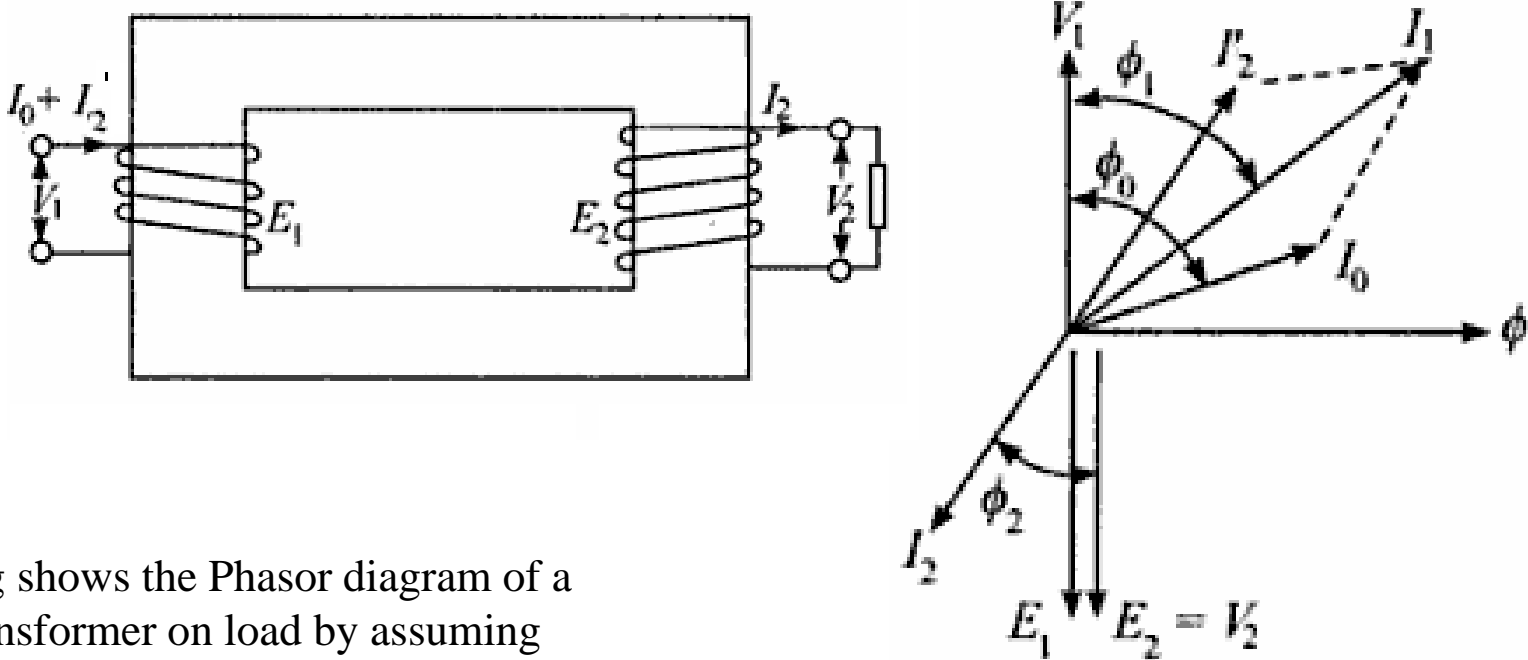

Fig shows the Phasor diagram of a transformer on load by assuming

1. No voltage drop in the winding
2. Equal no. of primary and secondary turns

# Transformer on load

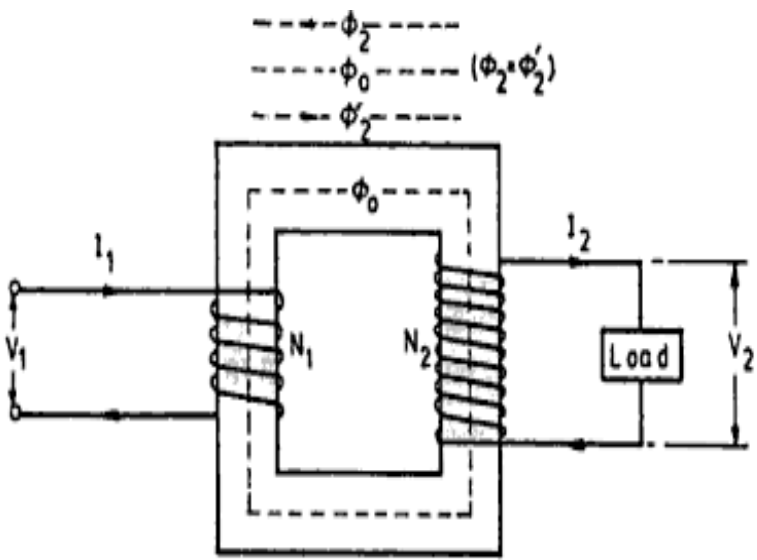

Fig. a: Ideal transformer on load

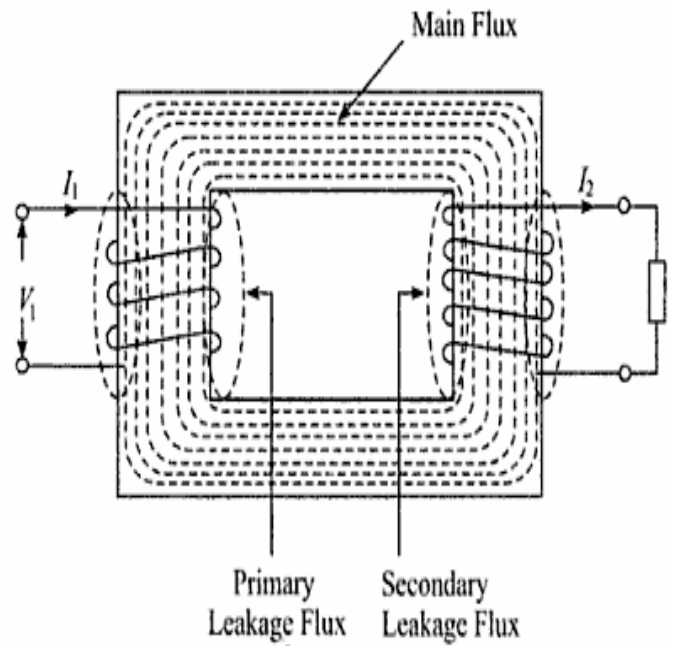
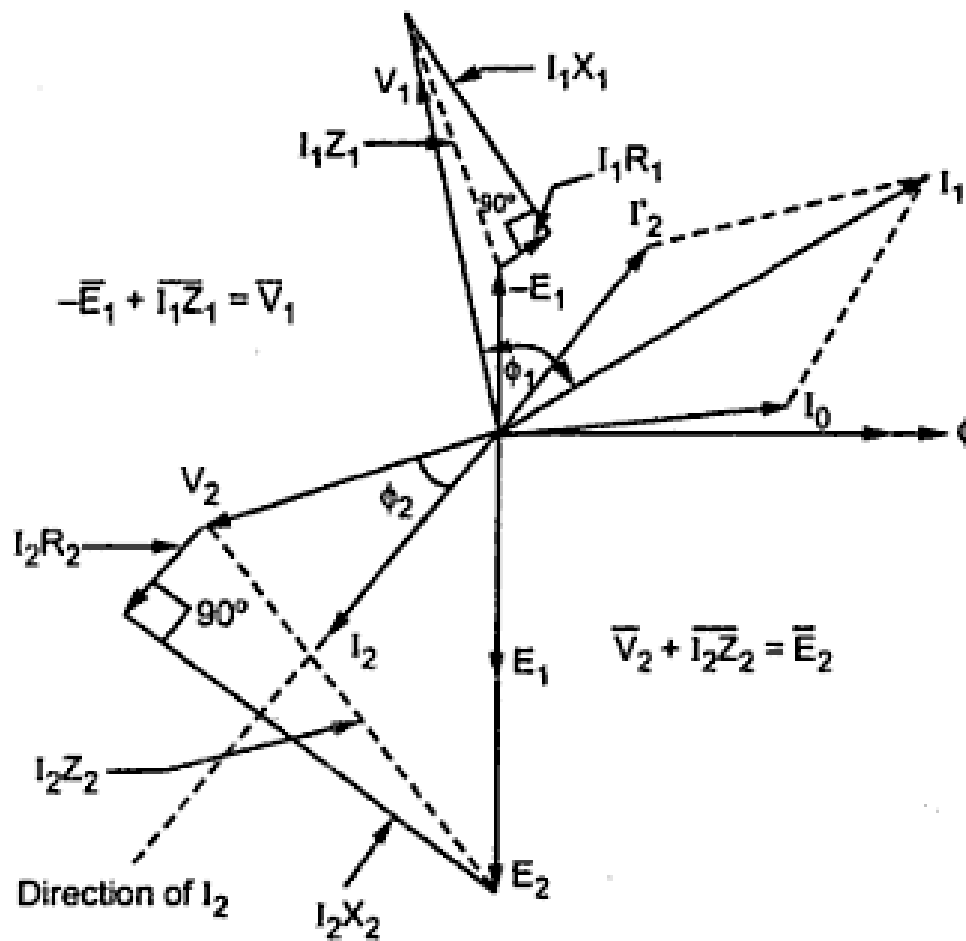

Fig. b: Main flux and leakage flux in a transformer





# Phasor diagram of transformer with leading p.f load



# Equivalent circuit of a transformer

## No load equivalent circuit:

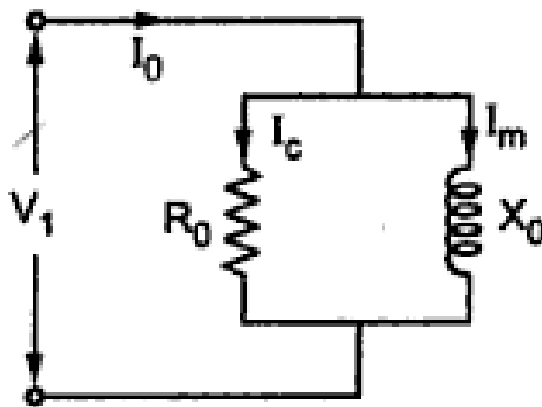

$$R_0 = \frac{V_1}{I_c}$$

$$X_0 = \frac{V_1}{I_m}$$

$$I_m = I_0 \sin \phi_0 = \text{Magnetising component}$$

$$I_c = I_0 \cos \phi_0 = \text{Active component}$$

Equivalent circuit parameters referred to primary and secondary sides respectively

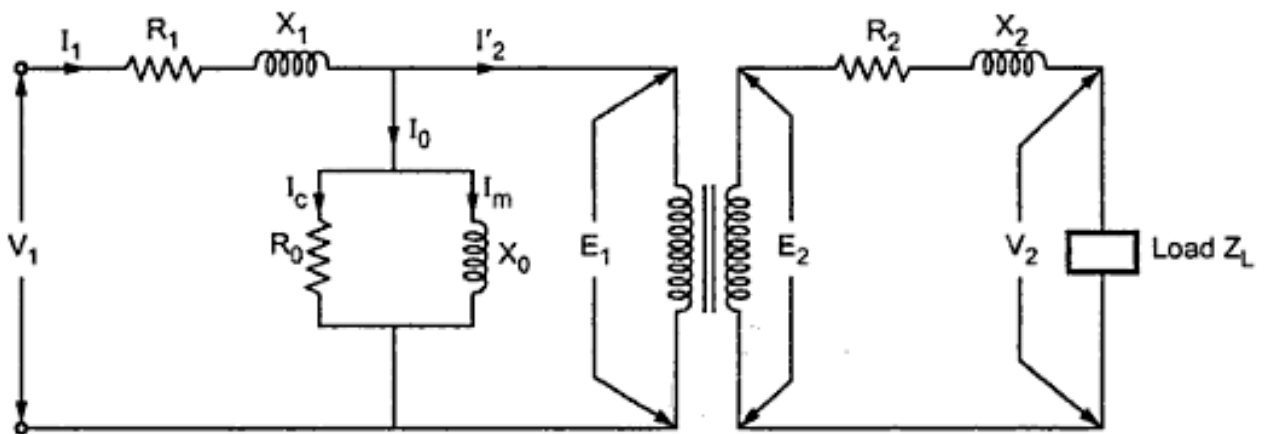
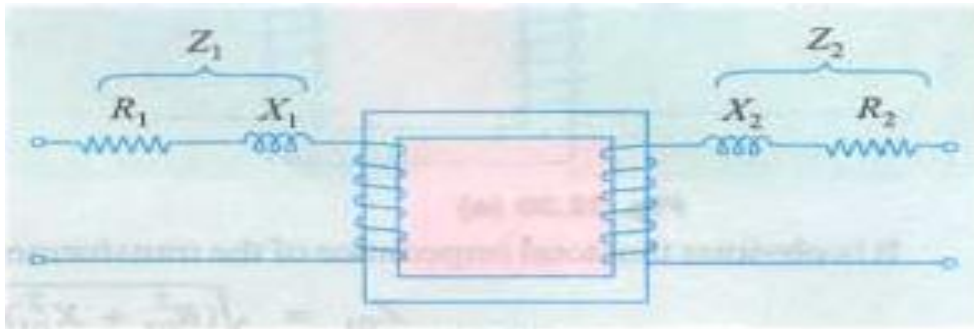

## Contd.,

- The effect of circuit parameters shouldn't be changed while transferring the parameters from one side to another side
- It can be proved that a resistance of  $R_2$  in sec. is equivalent to  $R_2/k^2$  will be denoted as  $R_2'$  (ie. Equivalent sec. resistance w.r.t primary) which would have caused the same loss as  $R_2$  in secondary,

$$\begin{aligned} I_1^2 R_2' &= I_2^2 R_2 \\ R_2' &= \left( \frac{I_2}{I_1} \right)^2 R_2 \\ &= \frac{R_2}{k^2} \end{aligned}$$

# Transferring secondary parameters to primary side

$$R'_2 = \frac{R_2}{K^2}, \quad X'_2 = \frac{X_2}{K^2}, \quad Z'_2 = \frac{Z_2}{K^2}$$

While  $E'_2 = \frac{E_2}{K}, \quad I'_2 = KI_2$

where  $K = \frac{N_2}{N_1}$

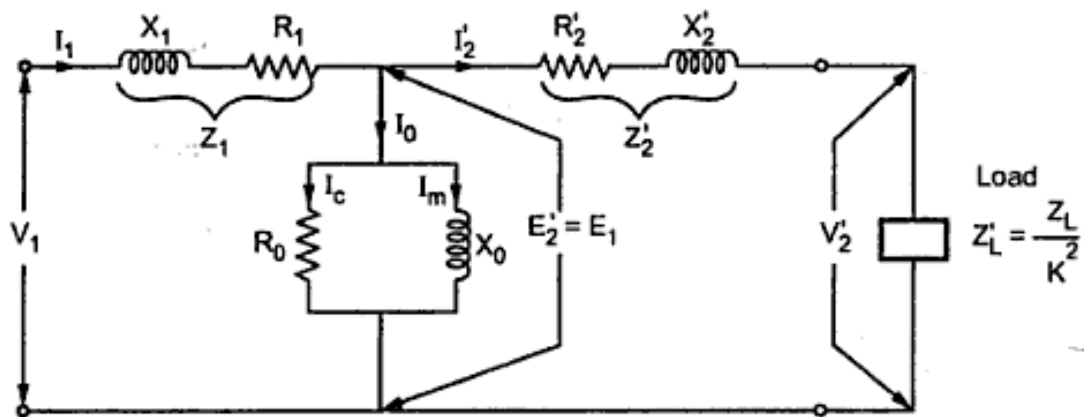

**Exact equivalent circuit referred to primary**

# Equivalent circuit referred to secondary side

- Transferring primary side parameters to secondary side

$$R'_1 = K^2 R_1, \quad X'_1 = K^2 X_1, \quad Z'_1 = K^2 Z_1$$

$$E'_1 = K E_1, \quad I'_1 = \frac{I_1}{K}, \quad I'_0 = \frac{I_0}{K}$$

Similarly exciting circuit parameters are also transferred to secondary as  $R'_0$  and  $X'_0$

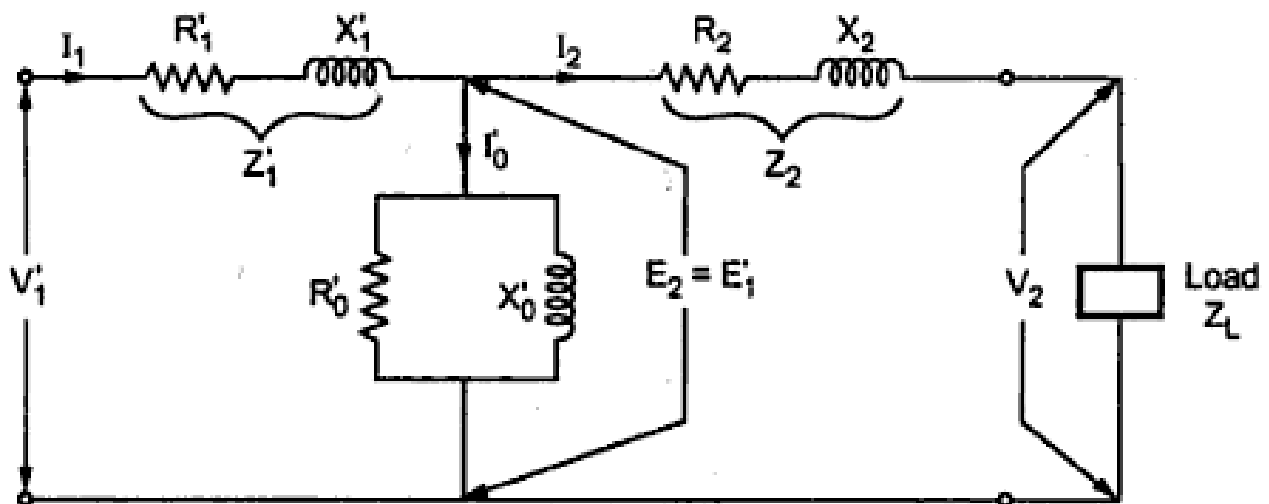

equivalent circuit w.r.t primary

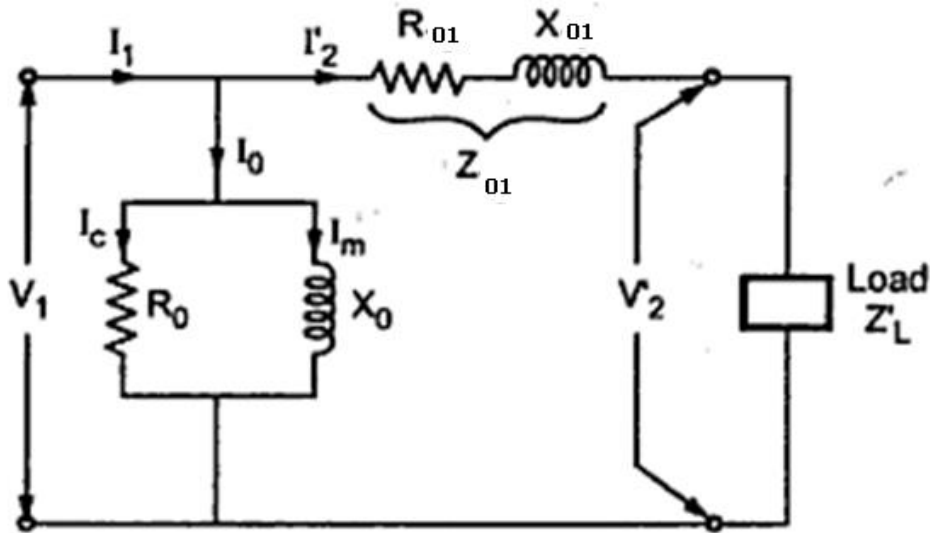
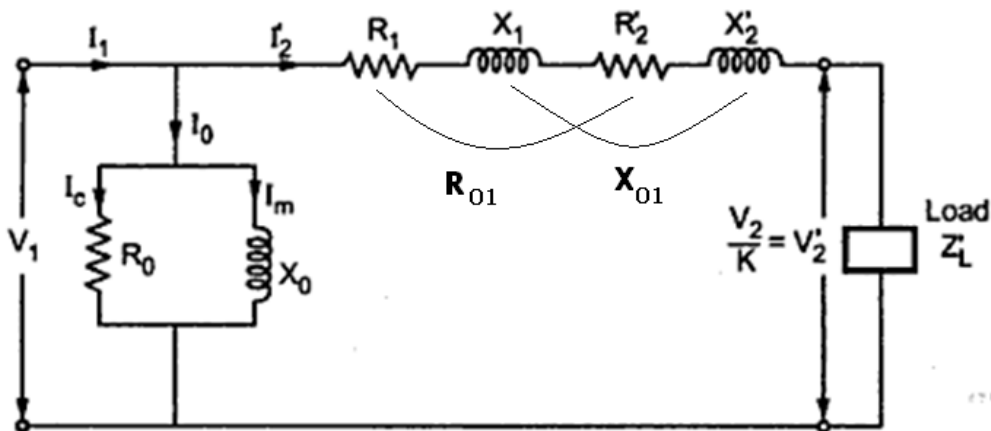

where

$$R_{01} = R_1 + R'_2 = R_1 + \frac{R_2}{K^2}$$

$$X_{01} = X_1 + X'_2 = X_1 + \frac{X_2}{K^2}$$

$$Z_{01} = R_{01} + j X_{01}$$

# Approximate equivalent circuit

- Since the no-load current is 1% of the full load current, the no-load circuit can be neglected

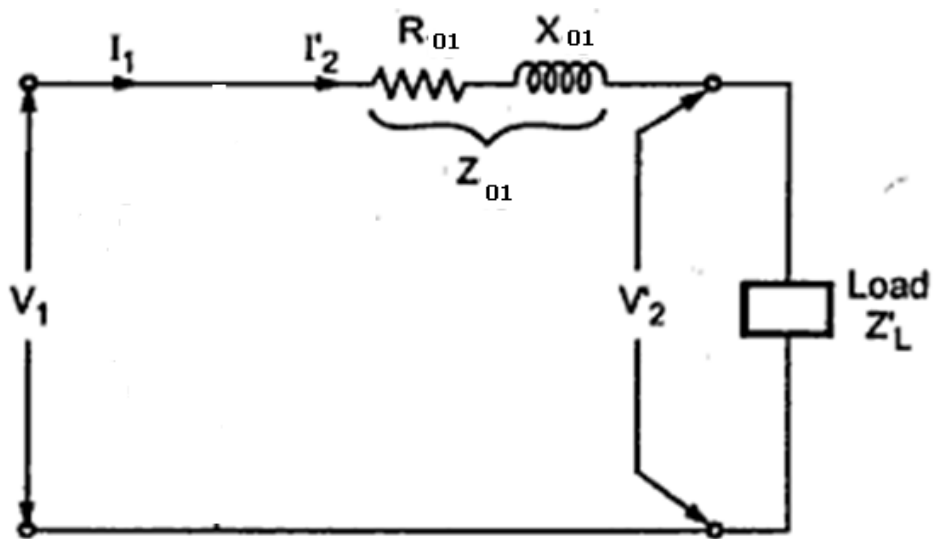

# Transformer Tests

- The performance of a transformer can be calculated on the basis of equivalent circuit
- The four main parameters of equivalent circuit are:
  - $R_{01}$  as referred to primary (or secondary  $R_{02}$ )
  - the equivalent leakage reactance  $X_{01}$  as referred to primary (or secondary  $X_{02}$ )
  - Magnetising susceptance  $B_0$  ( or reactance  $X_0$ )
  - core loss conductance  $G_0$  (or resistance  $R_0$ )
- The above constants can be easily determined by two tests
  - Open circuit test (O.C test / No load test)
  - Short circuit test (S.C test/Impedance test)
- These tests are economical and convenient
  - these tests furnish the result without actually loading the transformer

# Open-circuit Test

In Open Circuit Test the transformer's **secondary winding is open-circuited**, and its **primary winding is connected to a full-rated line voltage**.

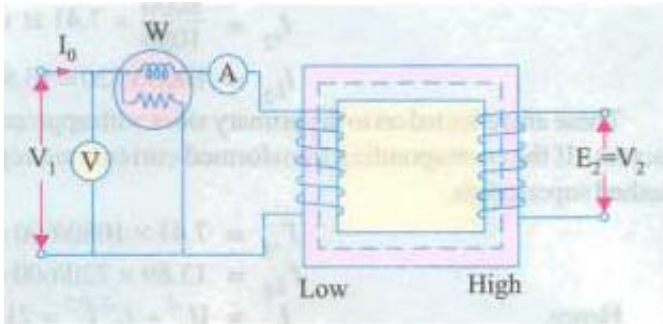

$$\text{Core loss} = W_{oc} = V_0 I_0 \cos \phi_0$$

$$\cos \phi_0 = \frac{W_{oc}}{V_0 I_0}$$

$$I_c \text{ or } I_w = I_0 \cos \phi_0$$

$$I_m \text{ or } I_\mu = I_0 \sin \phi_0 = \sqrt{I_0^2 - I_w^2}$$

$$I_0 = V_0 Y_0; \quad \therefore Y_0 = \frac{I_0}{V_0}$$

$$W_{oc} = V_0^2 G_0; \quad \therefore \text{Exciting conductance } G_0 = \frac{W_{oc}}{V_0^2}$$

$$R_0 = \frac{V_0}{I_w}$$

$$X_0 = \frac{V_0}{I_\mu}$$

$$G_0 = \frac{I_w}{V_0}$$

$$B_0 = \frac{I_\mu}{V_0}$$

- Usually conducted on H.V side
- To find
  - (i) No load loss or core loss
  - (ii) No load current  $I_0$  which is helpful in finding  $G_0$  (or  $R_0$ ) and  $B_0$  (or  $X_0$ )

$$\& \quad \text{Exciting susceptance } B_0 = \sqrt{Y_0^2 - G_0^2}$$

## Short-circuit Test

In Short Circuit Test the **secondary terminals are short circuited**, and the **primary terminals are connected to a fairly low-voltage source**

**The input voltage is adjusted until the current in the short circuited windings is equal to its rated value.** The input voltage, current and power is measured.

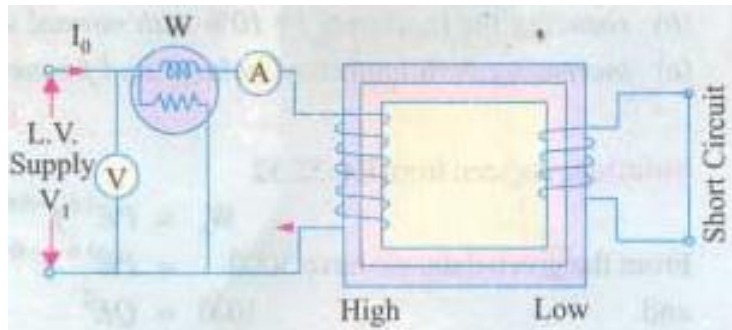

- Usually conducted on L.V side
- To find
  - (i) Full load copper loss – to pre determine the efficiency
  - (ii)  $Z_{01}$  or  $Z_{02}$ ;  $X_{01}$  or  $X_{02}$ ;  $R_{01}$  or  $R_{02}$  - to predetermine the voltage regulation

Contd...

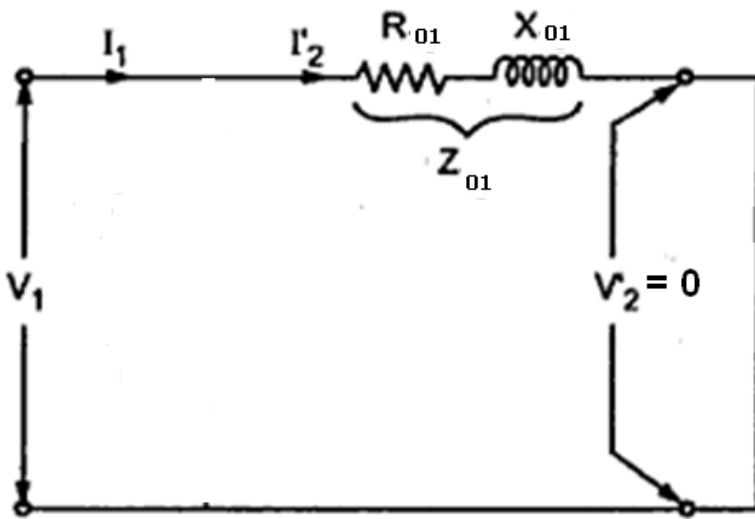

$$\text{Full load cu loss} = W_{sc} = I_{sc}^2 R_{01}$$

$$R_{01} = \frac{W_{sc}}{I_{sc}^2}$$

$$Z_{01} = \frac{V_{sc}}{I_{sc}}$$

$$\therefore X_{01} = \sqrt{Z_{01}^2 - R_{01}^2}$$

# Transformer Voltage Regulation and Efficiency

The output voltage of a transformer varies with the load even if the input voltage remains constant. This is because a real transformer has series impedance within it. Full load Voltage Regulation is a quantity that compares the output voltage at no load with the output voltage at full load, defined by this equation:

$$\text{Regulation up} = \frac{V_{S,nl} - V_{S,fl}}{V_{S,fl}} \times 100\%$$

$$\text{Regulation down} = \frac{V_{S,nl} - V_{S,fl}}{V_{S,nl}} \times 100\%$$

$$\text{At no load } k = \frac{V_s}{V_p}$$

$$\text{Regulation up} = \frac{(V_p / k) - V_{S,fl}}{V_{S,fl}} \times 100\%$$

$$\text{Regulation down} = \frac{(V_p / k) - V_{S,fl}}{V_{S,nl}} \times 100\%$$

Electrical Machines

***Ideal transformer, VR = 0%.***

# Voltage regulation of a transformer

$$\text{Voltage regulation} = \frac{\text{no - load voltage} - \text{full - load voltage}}{\text{no - load voltage}}$$

recall  $\frac{V_s}{V_p} = \frac{N_s}{N_p}$

Secondary voltage on no-load  $V_2 = V_1 \left( \frac{N_2}{N_1} \right)$

$V_2$  is a secondary terminal voltage on full load

Substitute we have

$$\text{Voltage regulation} = \frac{V_1 \left( \frac{N_2}{N_1} \right) - V_2}{V_1 \left( \frac{N_2}{N_1} \right)}$$

# Transformer Phasor Diagram

To determine the voltage regulation of a transformer, it is necessary understand the voltage drops within it.

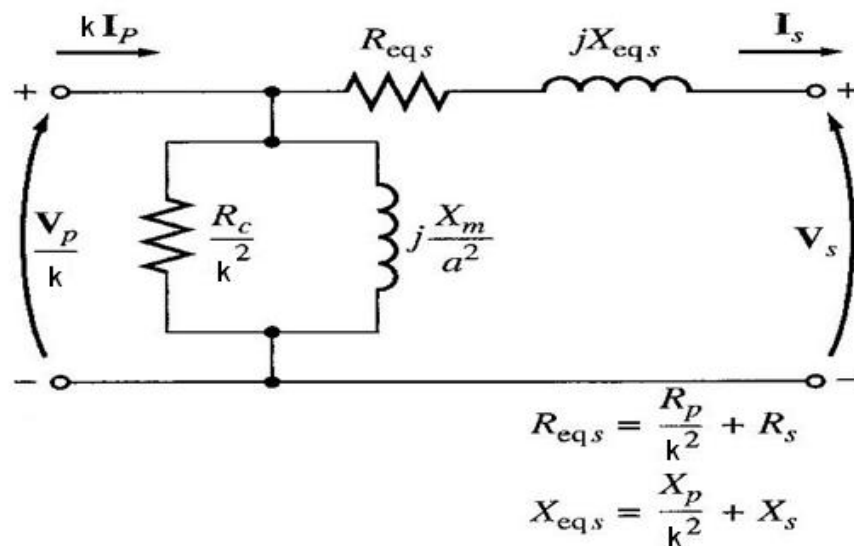

11/1/2023

# Transformer Phasor Diagram

Ignoring the excitation of the branch (since the current flow through the branch is considered to be small), more consideration is given to the series impedances ( $R_{eq} + jX_{eq}$ ).

***Voltage Regulation depends on magnitude of the series impedance and the phase angle of the current flowing through the transformer.***

Phasor diagrams will determine the effects of these factors on the voltage regulation. A phasor diagram consist of current and voltage vectors.

Assume that the reference phasor is the secondary voltage,  $V_S$ . Therefore the reference phasor will have 0 degrees in terms of angle.

***Based upon the equivalent circuit, apply Kirchoff Voltage Law,***

$$\frac{V_P}{k} = V_S + R_{eq} I_S + jX_{eq} I_S$$

# Transformer Phasor Diagram

*For lagging loads,  $V_p / a > V_c$  so the voltage regulation with lagging loads is  $> 0$ .*

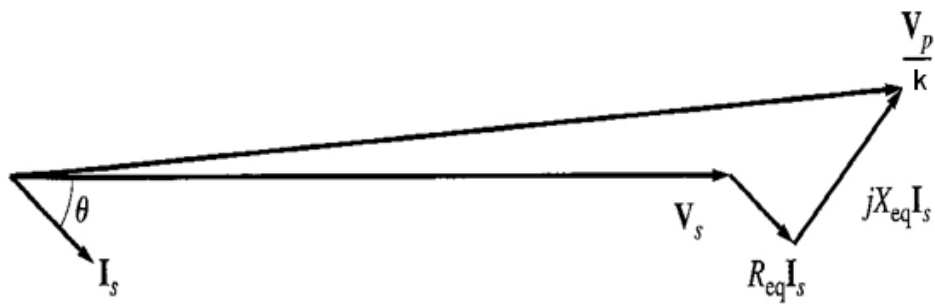

*When the power factor is unity,  $V_s$  is lower than  $V_p$  so  $VR > 0$ .*

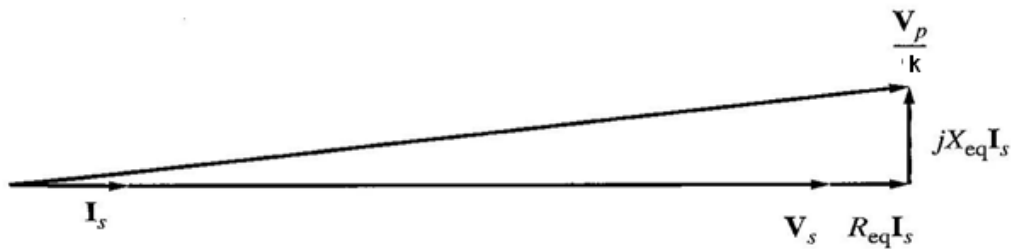

(a)

11/1/2023

# Transformer Phasor Diagram

*With a leading power factor,  $V_s$  is higher than the referred  $V_p$  so  $V_R < 0$*

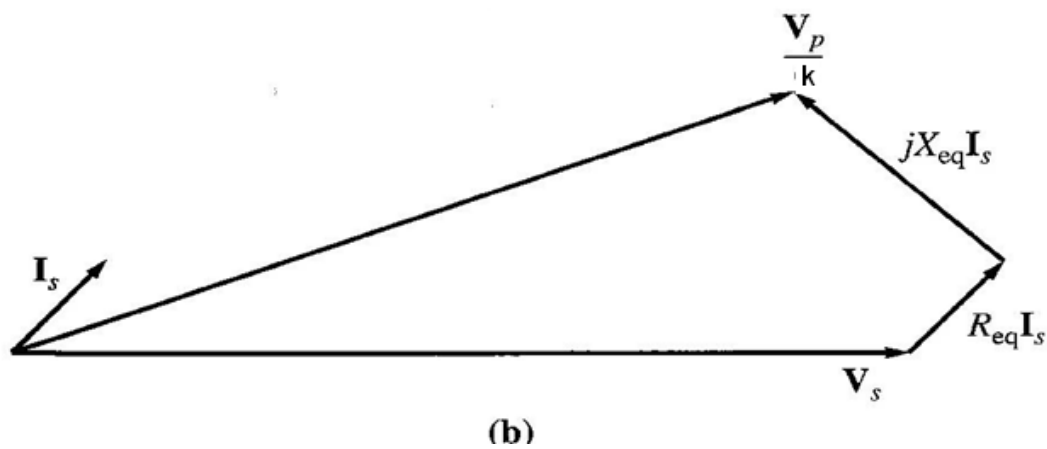

11/1/2023

Electrical Machines

© Aamir Hasan Khan

# Transformer Phasor Diagram

For lagging loads, the vertical components of  $R_{eq}$  and  $X_{eq}$  will partially cancel each other. Due to that, the angle of  $V_p/a$  will be very small, hence we can assume that  $V_p/k$  is horizontal. Therefore the approximation will be as follows:

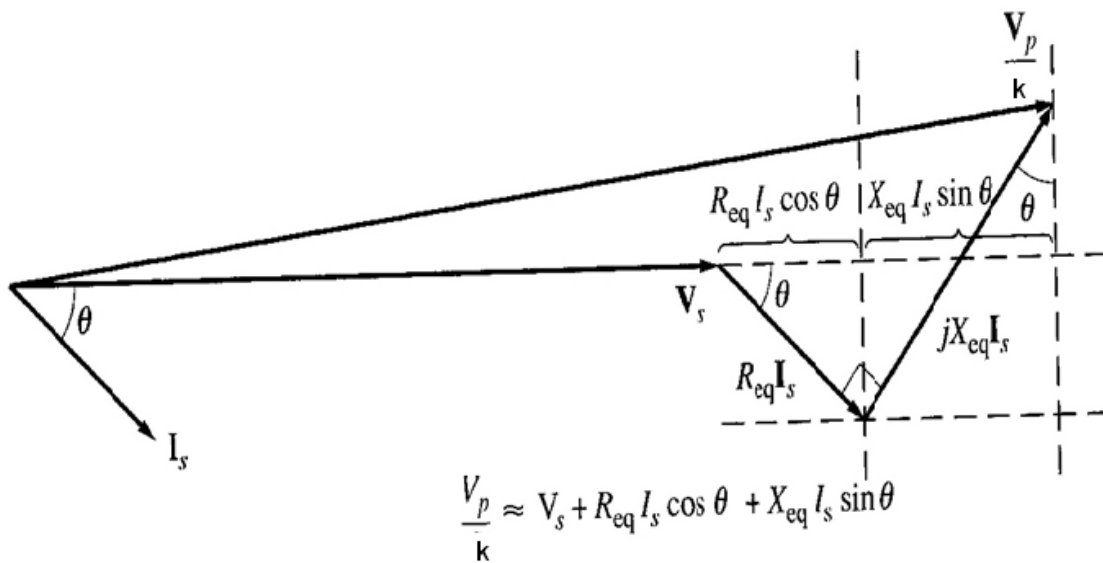

# Formula: voltage regulation

In terms of secondary values

$$\% \text{ regulation} = \frac{{}_0V_2 - V_2}{{}_0V_2} = \frac{I_2 R_{02} \cos \phi_2 \pm I_2 X_{02} \sin \phi_2}{{}_0V_2}$$

where '+' for lagging and '-' for leading

In terms of primary values

$$\% \text{ regulation} = \frac{V_1 - V_2'}{V_1} = \frac{I_1 R_{01} \cos \phi_1 \pm I_1 X_{01} \sin \phi_1}{V_1}$$

where '+' for lagging and '-' for leading

# Transformer Efficiency

Transformer efficiency is defined as (applies to motors, generators and transformers):

$$\eta = \frac{P_{out}}{P_{in}} \times 100\%$$

$$\eta = \frac{P_{out}}{P_{out} + P_{loss}} \times 100\%$$

Types of losses incurred in a transformer:

Copper I<sup>2</sup>R losses

Hysteresis losses

Eddy current losses

Therefore, for a transformer, efficiency may be calculated using the following:

$$\eta = \frac{V_S I_S \cos\theta}{P_{Cu} + P_{core} + V_S I_S \cos\theta} \times 100\%$$

Electrical Machines

# Losses in a transformer

Core or Iron loss:

$$\text{Hysteresis loss } W_h = \eta B_{\max}^{1.6} f V \text{ watt;}$$

$$\text{eddy current loss } W_e = \eta B_{\max}^2 f^2 t^2 \text{ watt}$$

Copper loss:

$$\text{Total Cu loss } = I_1^2 R_1 + I_2^2 R_2 = I_1^2 R_{01} + I_2^2 R_{02}$$

# Condition for maximum efficiency

$$\text{Cu loss} = I_1^2 R_{01} \text{ or } I_2^2 R_{02} = W_{cu}$$

$$\text{Iron loss} = \text{Hysteresis loss} + \text{Eddy current loss} = W_h + W_e = W_i$$

Considering primary side,

$$\text{Primary input} = V_1 I_1 \cos \phi_1$$

$$\eta = \frac{V_1 I_1 \cos \phi_1 - \text{losses}}{V_1 I_1 \cos \phi_1} = \frac{V_1 I_1 \cos \phi_1 - I_1^2 R_{01} - W_i}{V_1 I_1 \cos \phi_1}$$

$$= 1 - \frac{I_1 R_{01}}{V_1 \cos \phi_1} - \frac{W_i}{V_1 I_1 \cos \phi_1}$$

Differentiating both sides with respect to  $I_1$ , we get

$$\frac{d\eta}{dI_1} = 0 - \frac{R_{01}}{V_1 \cos \phi_1} + \frac{W_i}{V_1 I_1^2 \cos \phi_1}$$

For  $\eta$  to be maximum,  $\frac{d\eta}{dI_1} = 0$ . Hence, the above equation becomes

$$\frac{R_{01}}{V_1 \cos \phi_1} = \frac{W_i}{V_1 I_1^2 \cos \phi_1} \quad \text{or} \quad W_i = I_1^2 R_{01} \quad \text{or} \quad I_2^2 R_{02}$$

or

$$\text{Cu loss} = \text{Iron loss}$$

Contd.,

The output current corresponding to maximum efficiency is  $I_2 = \sqrt{(W_i/R_{02})}$ .

The load at which the two losses are equal = Full load  $\times \sqrt{\left(\frac{\text{Iron loss}}{\text{F.L. Cu loss}}\right)}$

# All day efficiency

ordinary commercialefficiency=  $\frac{\text{out put in watts}}{\text{input in watts}}$

$$\eta_{all\ day} = \frac{\text{output in kWh}}{\text{Input in kWh}} \text{ (for 24 hours)}$$

- All day efficiency is always less than the commercial efficiency

# 3-Phase Transformer Construction, Principal, Working, Operation Advantages Over 1-Phase Transformer

- \* Introduction
- \* Advantages
- \* Construction
- \* Principal
- \* Working

## \* Introduction

\* The generation of an electrical power is usually three phase and at higher voltages like 13.2 KV, 22 KV or some what higher, Similarly transmission of an electrical power is also at very high voltages like 110 KV, 132 KV, 400 KV. To step up the generated voltages for transmission purposes it is necessary to have three phase transformers.

# \* Advantages

\* Less space

\* Weight Less

\* Cost is Less

\* Transported easily

\* Core will be smaller size

\* More efficient

\* Structure, switchgear and installation of single three phase unit is simpler

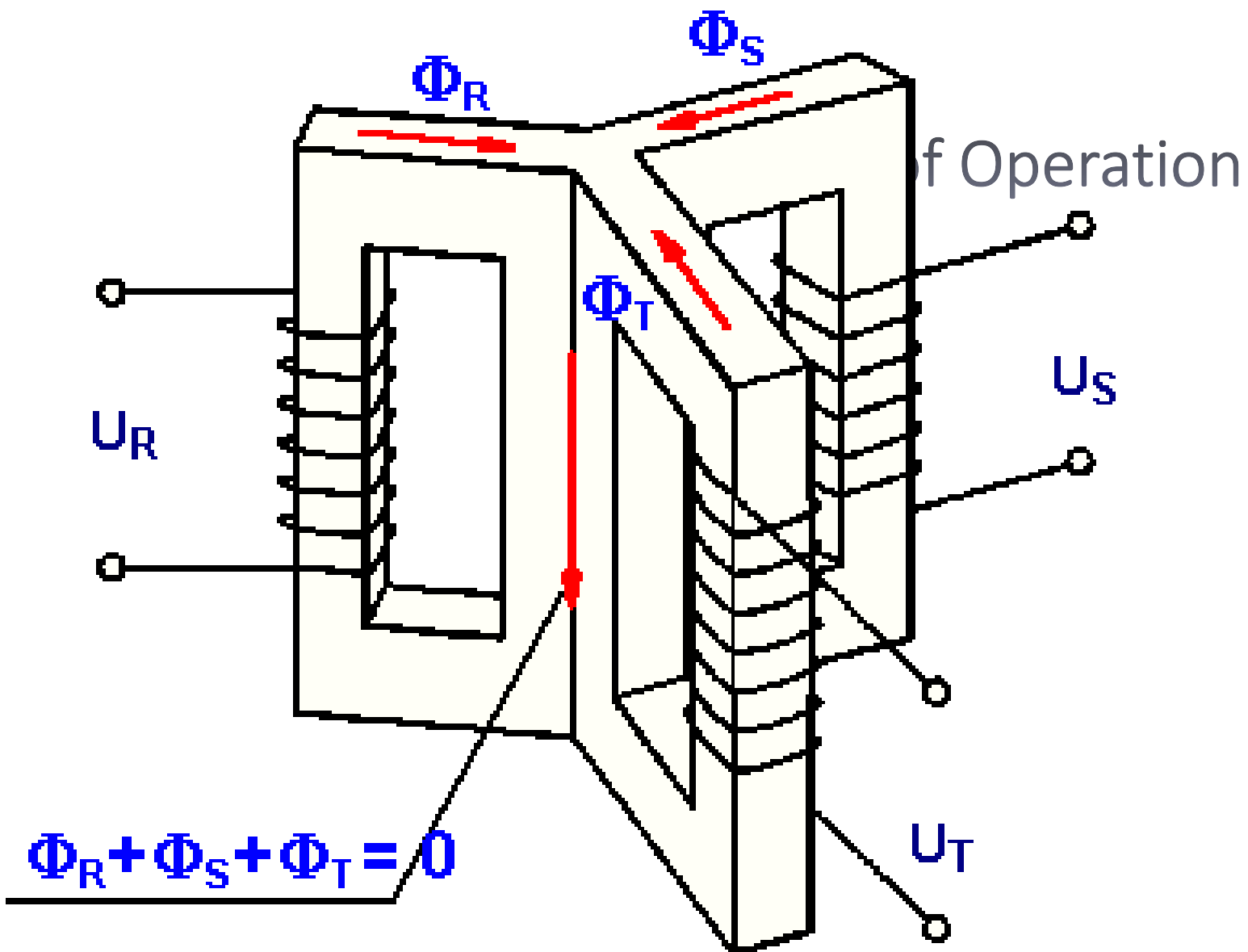

\*The three cores are arranged at  $120^\circ$  from each other. Only primary windings are shown on the cores for simplicity.

\*The primaries are connected to the three phase supply.

\*The three fluxes are also zero at any instant.

\* Hence the centre leg does not carry any flux.

\* So if centre leg is removed, any two legs provide the return path for the current and hence the flux in the third leg.

\* This is the general principle used in the design of three phase core type transformers.

## \*Three Phase Transformer Connection

\*The primary and secondary winding of three phase transformers as three phase winding can be connected in different ways such as in star or in delta. With suitable connection the voltage can be raised or lowered.

\*In this section some commonly used connections for three phase transformers are discussed.

- \* Star-Star connection
- \* Delta-Delta connection
- \* Star-Delta connection
- \* Delta-Star connection
- \* Open Delta or V connection
- \* Scott connection or T-T connection

### 3 Single Phase Transformers

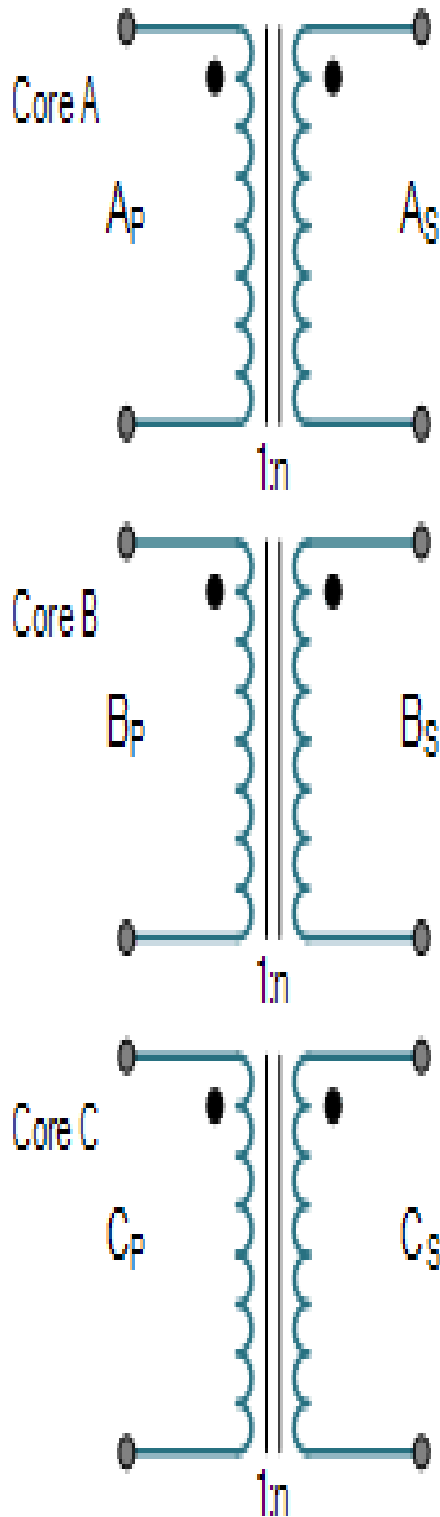

Primary Configuration		Secondary Configuration	
Delta (Mesh)		Delta (Mesh)	
Delta (Mesh)		Star (Wye)	
Star (Wye)		Delta (Mesh)	
Star (Wye)		Star (Wye)	
Interconnected Star		Delta (Mesh)	
Interconnected Star		Star (Wye)	

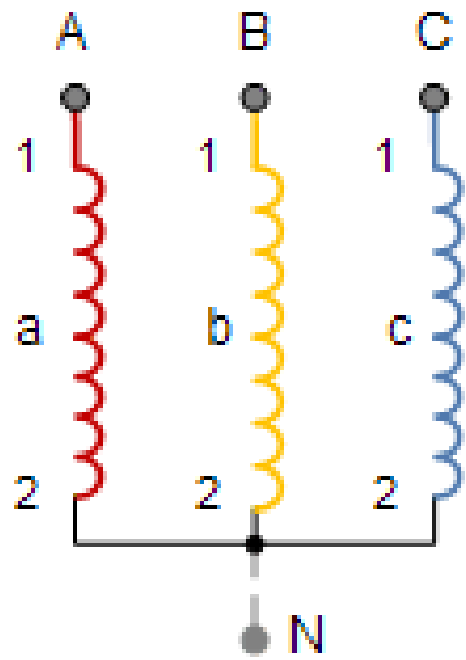

Star Connection

≡

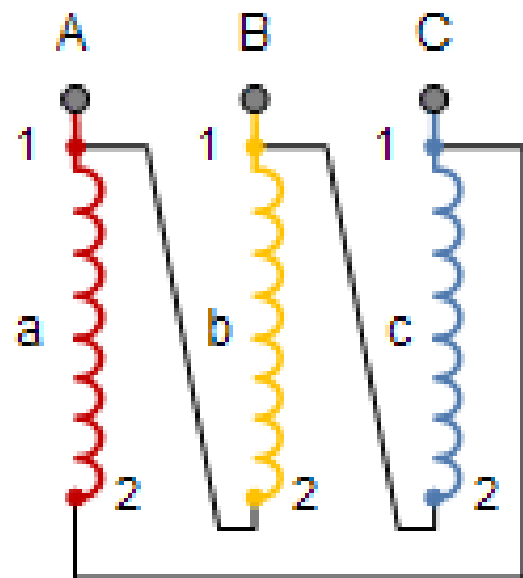
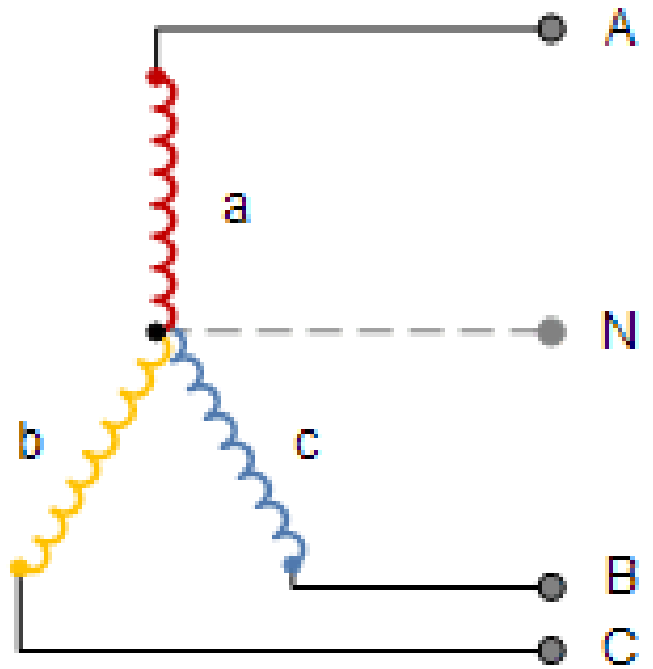

Delta Connection

≡

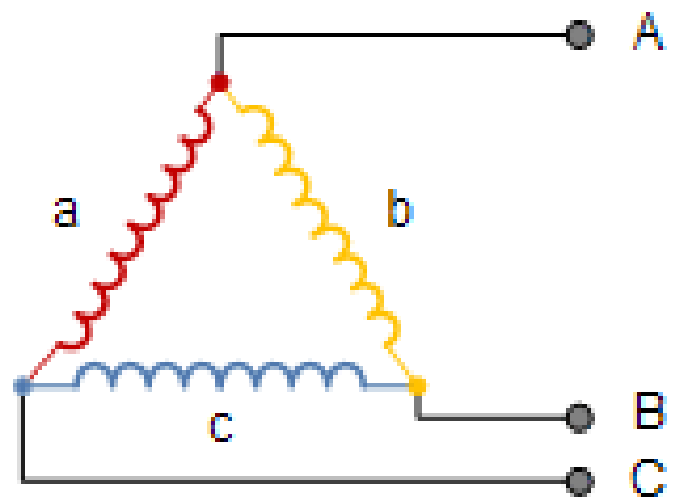

### 3-phase, Wye-connected transformer

Voltages in black refer to a transformer with 400 V from phase to phase \*  
 Voltages in grey refer to a transformer with 480 V from phase to phase \*

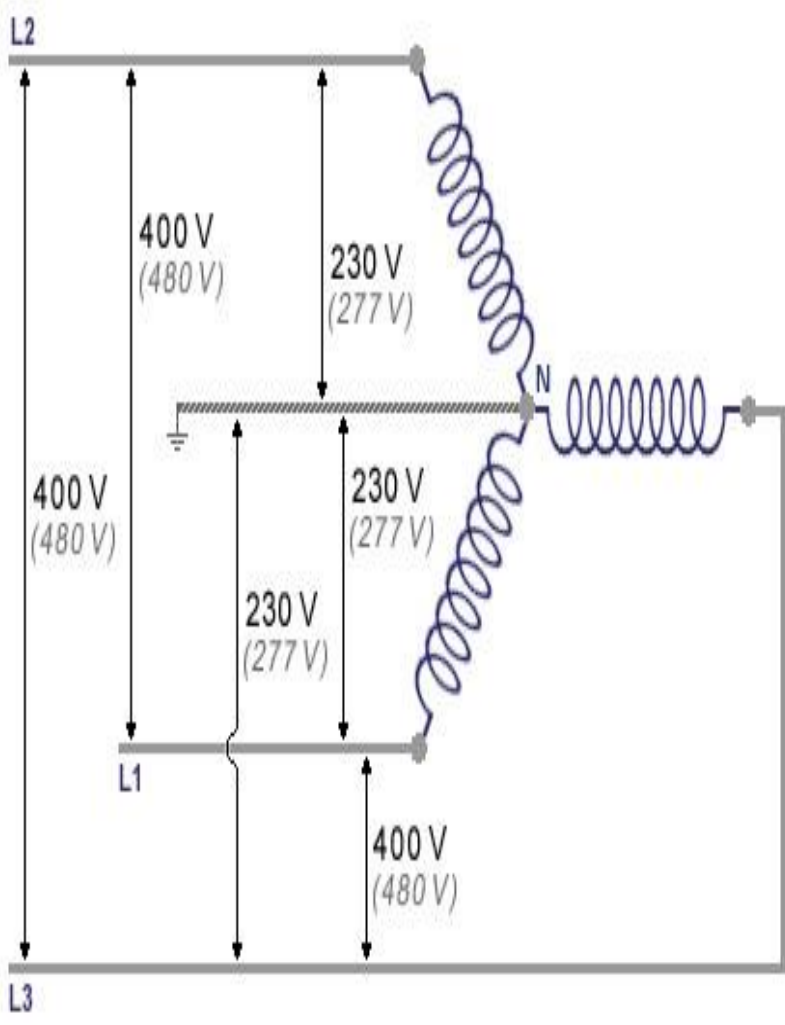

### 3-phase, Delta-connected transformer

(shown is a split-phase or high leg delta type)

Voltages refer to a transformer with 240 V from phase to phase \*

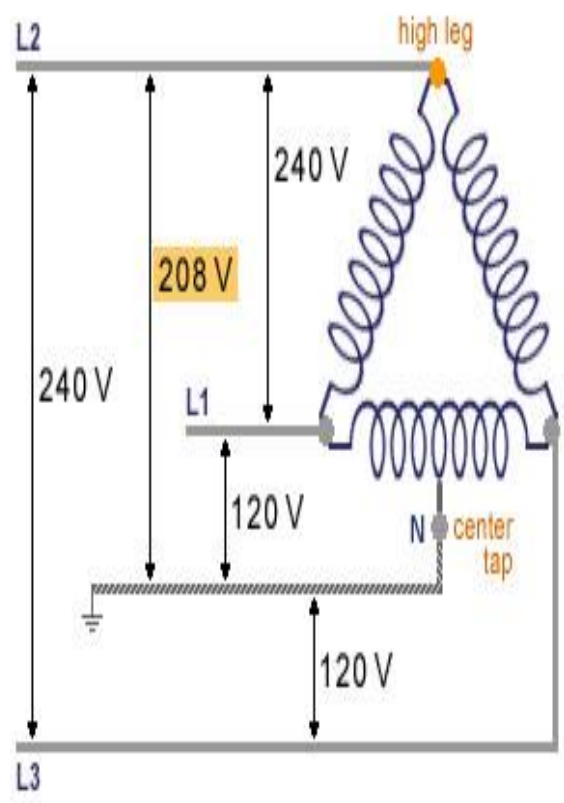

\* Note that for each transformer only the secondary windings are shown.

L1, L2 and L3: conductors of a three phase system (colour coding varies between countries).

## \* Parallel Operation of Three Phase Transformer

\*The transformers are connected in parallel when load on one of the transformers is more than its capacity.

\*The reliability is increased with parallel operation than to have single larger unit.

\*The Transformers connected in parallel must have same polarity so that the resultant voltage around the local loop is zero. With improper polarities there are chances of dead short circuit.

\*The relative phase displacements on the secondary sides of the three phase transformers to be connected in parallel must be zero. The transformers with same phase group can be connected in parallel

\* As the phase shift between the secondary voltages of a star/delta and delta/star transformers is  $30^\circ$ , They cannot be connected in parallel.

\* But transformers with  $+30^\circ$  and  $-30^\circ$  phase shift can be connected in parallel by reversing phase sequence of one of them

\*The voltage ratio of the two transformers must be same. This prevents no load circulating current when the transformers are in parallel on primary and secondary sides.

\*As the leakage impedance is less, with a small voltage difference no load circulating current is high resulting in large  $I^2R$  losses.